

Electricity, Magnetism, Optics and Modern Physics

College Physics II: Notes and exercises

Daniel Gebreselasie

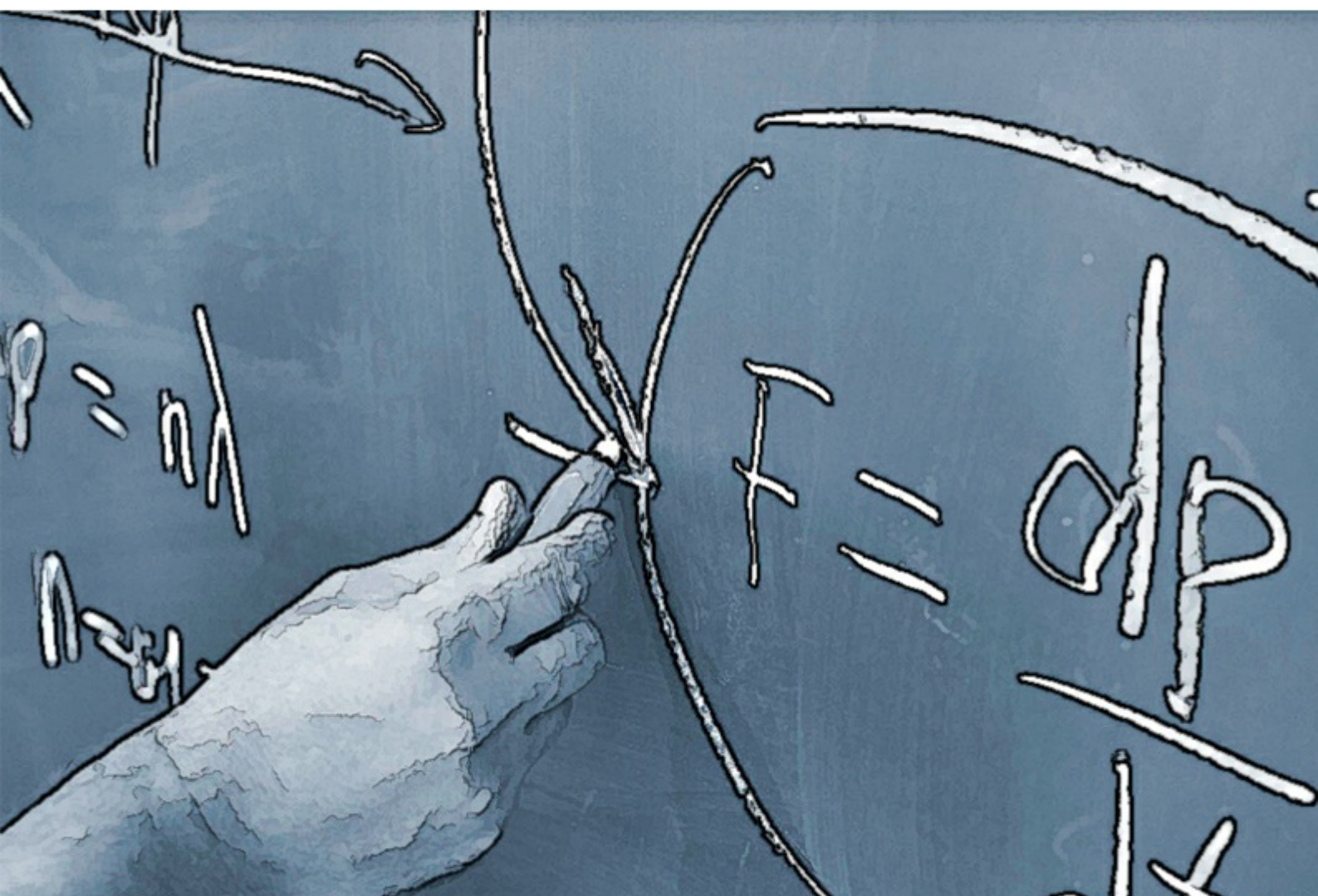

DANIEL GEBRESELASIE

**ELECTRICITY,
MAGNETISM, OPTICS
AND MODERN PHYSICS**
COLLEGE PHYSICS II:
NOTES AND EXERCISES

Electricity, Magnetism, Optics and Modern Physics:
College Physics II: Notes and exercises
1st edition
© 2015 Daniel Gebreselasie & bookboon.com
ISBN 978-87-403-1056-6

CONTENTS

| | | |
|----------|---------------------------------------------|----------|
| 1 | Electric Force and Electric Field | 8 |
| 1.1 | Electric Force | 8 |
| 1.2 | Coulomb's Law | 9 |
| 1.3 | Superposition Principle for Electric Forces | 10 |
| 1.4 | Brief Review of Vector Addition | 11 |
| 1.5 | Practice Quiz 1.1 | 16 |
| 1.6 | Electric Field | 19 |
| 1.7 | Electric Field due to a Point Charge | 22 |
| 1.8 | Superposition Principle for Electric Field | 23 |
| 1.9 | Electric Field Lines | 26 |
| 1.10 | Electric Field Lines due to Point Charges | 26 |
| 1.11 | Practice Quiz 1.2 | 30 |



Discover the truth at www.deloitte.ca/careers

Deloitte.

© Deloitte & Touche LLP and affiliated entities.

| | | |
|----------|-------------------------------------------------------|-----------|
| 2 | Electrical Energy and Capacitance | 33 |
| 2.1 | Electrical Energy | 33 |
| 2.2 | Potential Difference | 35 |
| 2.3 | Electric Potential due to a Point Charge | 38 |
| 2.4 | Superposition Principle for Electric Potential | 39 |
| 2.5 | Electric Potential Energy Stored by Two Point Charges | 40 |
| 2.6 | Conductors in Electrostatic Equilibrium | 41 |
| 2.7 | Equipotential Surfaces | 41 |
| 2.8 | Practice Quiz 2.1 | 43 |
| 2.9 | Capacitors | 47 |
| 2.10 | Electrical Energy Stored by a Capacitor | 49 |
| 2.11 | Parallel combination of Capacitors | 50 |
| 2.12 | Series Combination of Capacitors | 53 |
| 2.13 | Parallel-Series Combination of Capacitors | 56 |
| 2.14 | Practice Quiz 2.2 | 58 |
| 3 | Current and Resistance | 62 |
| 3.1 | Current | 62 |
| 3.2 | Resistance | 62 |
| 3.3 | Resistance of a wire | 64 |
| 3.4 | Resistivity and Temperature | 65 |
| 3.5 | Practice Quiz 3.1 | 66 |
| 3.6 | Resistance and Temperature | 68 |
| 3.7 | Power Dissipation in a Resistor | 69 |
| 3.8 | Practice Quiz 3.2 | 72 |
| 4 | Direct Current Circuits | 75 |
| 4.1 | Electromotive Force of a Source | 75 |
| 4.2 | Power of a source | 77 |
| 4.3 | Combination of Resistors | 79 |
| 4.4 | Practice Quiz 4.1 | 86 |
| 4.5 | Kirchoff's Rules | 91 |
| 4.6 | Practice Quiz 4.2 | 98 |

| | | |
|----------|--------------------------------------------------------------------------------------------|------------|
| 5 | Magnetism | 101 |
| 5.1 | Magnetic Field | 101 |
| 5.2 | Magnetic Force on a Charge Moving in a Magnetic Field | 103 |
| 5.3 | Magnetic Torque on a Current Carrying Loop Placed in a Magnetic Field | 107 |
| 5.4 | Mass Spectrometer | 110 |
| 5.5 | Practice Quiz 5.1 | 110 |
| 5.6 | Galvanometers | 114 |
| 5.7 | Ampere's Law | 116 |
| 5.8 | Practice Quiz 5.2 | 122 |
| 6 | Induced Voltages and Inductance | 126 |
| 6.1 | Faraday's Law | 126 |
| 6.2 | Motional Emf | 133 |
| 6.3 | Practice Quiz 6.1 | 134 |
| 6.4 | Lenz's Rule | 138 |
| 6.5 | Generators | 142 |
| 6.6 | Inductors | 144 |
| 6.7 | Practice Quiz 6.2 | 145 |
| 7 | Alternating Current Circuits | 149 |
| 7.1 | A Resistor Connected to an ac Source | 151 |
| 7.2 | A Capacitor Connected to an ac Source | 152 |
| 7.3 | An Inductor Connected to an ac Source | 154 |
| 7.4 | Practice Quiz 7.1 | 155 |
| 7.5 | Series Combination of a Resistor, an Inductor and a Capacitor Connected to an ac Source | 158 |
| 7.6 | Practice Quiz 7.2 | 167 |
| 8 | Light and Optics | 172 |
| 8.1 | The History of Light | 172 |
| 8.2 | Reflection of Light | 175 |
| 8.3 | Refraction | 176 |
| 8.4 | Practice Quiz 8.1 | 179 |
| 8.5 | Dispersion of Light | 184 |
| 8.6 | Total Internal Reflection | 185 |
| 8.7 | Practice Quiz 8.2 | 188 |

| | | |
|-----------|-----------------------------------------|------------|
| 9 | Mirrors and Lenses | 191 |
| 9.1 | Mirrors | 191 |
| 9.2 | Practice Quiz 9.1 | 200 |
| 9.3 | Lenses | 203 |
| 9.4 | Practice Quiz 9.2 | 213 |
| 10 | Wave Properties of Light | 216 |
| 10.1 | Interference of Light | 216 |
| 10.2 | Polarization | 225 |
| 10.3 | Practice Quiz 10 | 226 |
| 11 | Relativity and Quantum Mechanics | 228 |
| 11.1 | The History of Modern Physics | 228 |
| 11.2 | The Michelson-Morley Experiment | 229 |
| 11.3 | The Black Body Radiation Experiment | 232 |
| 11.4 | The Photoelectric Effect Experiment | 233 |
| 11.5 | De Broglie's Hypothesis | 234 |
| 11.6 | Schrodinger's Equation | 235 |
| 11.7 | Heisenberg's Uncertainty Principle | 236 |
| 11.8 | Practice Quiz 11 | 236 |
| 12 | Atomic Physics | 239 |
| 12.1 | The history of the atom | 239 |
| 12.2 | Bohr's Model of the Atom | 240 |
| 12.3 | Quantum Numbers | 245 |
| 12.4 | Practice Quiz 12 | 248 |
| 13 | Nuclear Physics | 251 |
| 13.1 | Radio Activity | 252 |
| 13.2 | Binding Energy | 254 |
| 13.3 | Nuclear Reactions | 255 |
| 13.4 | Practice Quiz 13 | 256 |
| 14 | Answers to Practice Quizzes | 258 |

1 ELECTRIC FORCE AND ELECTRIC FIELD

Your goals for this chapter are to learn about electric forces and electric fields.

1.1 ELECTRIC FORCE

Experiment shows that when fur and rubber are rubbed together, they develop the property of attracting each other. This kind of force that arises after objects are rubbed together is called *electrical force*. The change that took place during the rubbing process that is responsible for this force is called *charge*.

Experiment also shows that when another set of rubber and fur are rubbed together, the two furs repel and the two rubbers repel each other. This indicates that there must be two kinds of charges because one object can attract one kind of charge and repel another kind of charge. These two kinds of charge are mathematically identified as positive and negative. It is safe to assume that the two furs have the same kind of charge and the two rubbers have the same charge. Therefore it follows that similar charges repel and opposite charges attract.

According to the current understanding of charges, charges are the result of the transfer of electrons from one object to another when the objects are rubbed together. Electrons are negatively charged. Thus, the object that gained electrons becomes negatively charged and the object that lost electrons becomes positively charged.

The unit of measurement for charge is the Coulomb, abbreviated as C. The charge of an electron in Coulombs is equal to $-1.6e-19$ C. The charge of a proton is numerically equal to that of the electron but is positive; that is the charge of a proton is $1.6e-19$ C. Charge is measured by an instrument called *electroscope*. An electroscope consists of a pair of gold leaves in a jar. When the gold leaves are brought in contact with a charged object, both leaves acquire the same charge and they repel each other. As a result the leaves deflect. The deflection angle is proportional to the amount of charge. Thus, charge can be measured by measuring the deflection angle.

There are two methods by which a neutral object can be charged. These are conduction and induction. *Conduction* is a process by which a neutral object is brought in direct contact with a charged object. In the process, the neutral object acquires the same kind of charge as the charging object. *Induction* is a process by which a neutral object is brought closer (without touching) to a charged object and then grounded (connected to the ground). In this process, the neutral object acquires opposite charge to that of the charging object.

Substances with free electrons are called *conductors*. Conductors are good conductors of electricity and heat. They are shiny and ductile (their shape can be changed without breaking). These are generally metals. Substances without free electrons are called *insulators*. Insulators are bad conductors of electricity and heat. They are dull and brittle (difficult to change shape without breaking). Examples are wood and glass.

1.2 COULOMB'S LAW

Coulomb's law states that any two charges exert electrical force on each other that is proportional to the product of the charges and inversely proportional to the square of the distance separating them. The direction of the force is along the line joining the centers of the charges. It is attractive if the charges are opposite and is repulsive if the charges have similar charges.

$$F = k|q_1||q_2|/r^2$$

F is the magnitude of the electrical force exerted by one on the other. q_1 and q_2 are the charges of the two objects. r is the distance between the charged objects. k is a universal constant called Coulomb's constant. Its value is $9e9 \text{ Nm}^2/\text{C}^2$.

$$k = 9e9 \text{ Nm}^2/\text{C}^2$$

Example: Object A and Object B are separated by a distance of 0.8 m as shown. Charge A has a charge of $-2 \mu\text{C}$. Object B has a charge of $4 \mu\text{C}$.

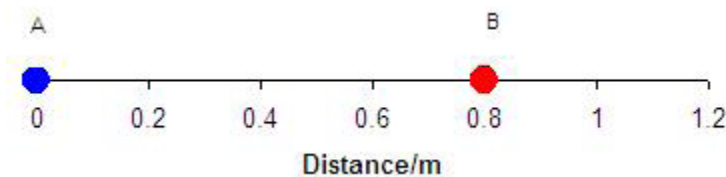

Figure 1.1

- a) Calculate the magnitude and direction of the electrical force exerted by object A on object B.

Solution: Since A and B have opposite charges, the force is attractive. Therefore the direction of the force exerted by object A on object B is west (left).

$$q_A = -2 \mu\text{C} = -2e-6 \text{ C}; q_B = 4 \mu\text{C} = 4e-6 \text{ C}; r = 0.8 \text{ m}; F_{BA} = ?$$

$$F_{BA} = k|q_A||q_B|/r^2 = 9e9 * |-2e-6||4e-6|/0.8^2 \text{ N} = 11.25 \text{ N}$$

- b) Calculate the magnitude and direction of the electrical force exerted by object B on object A.

Solution: The force exerted by object B on object A and the force exerted by object A on object B are action reaction forces; that is they have equal magnitudes and opposite directions. Therefore the direction of the force exerted by object B on object A is east (right).

$$F_{BA} = 11.25 \text{ N}; F_{AB} = ?$$

$$F_{AB} = F_{BA} = 11.25 \text{ N}$$

1.3 SUPERPOSITION PRINCIPLE FOR ELECTRIC FORCES

The *superposition principle for electric forces* states that if a charge is in a vicinity of a number of charges, the net electric force acting on the charge is the vector sum of all the forces exerted on the charge by the individual charges. If charges q_1, q_2, \dots, q_n are in the vicinity of a charge q , then the net force acting on the charge (F_{net}) is given by

$$\mathbf{F}_{net} = \mathbf{F}_1 + \mathbf{F}_2 + \dots + \mathbf{F}_n$$

where $\mathbf{F}_1, \mathbf{F}_2 \dots \mathbf{F}_n$ are the forces exerted by the charges $q_1, q_2 \dots q_n$.

1.4 BRIEF REVIEW OF VECTOR ADDITION

The horizontal (vertical) component of the sum of vectors is equal to the sum of the horizontal (vertical) components of the vectors being added; that is if $\mathbf{R} = \mathbf{A} + \mathbf{B} + \dots$, then

$$R_x = A_x + B_x + \dots$$

$$R_y = A_y + B_y + \dots$$

The magnitude and direction of the sum vector in terms of the components of the vectors being added are given as follows:

$$R = \sqrt{\{(A_x + B_x + \dots)^2 + (A_y + B_y + \dots)^2\}}$$

$$\theta = \arctan \{(A_y + B_y + \dots) / (A_x + B_x + \dots)\}$$

If $A_x + B_x + \dots < 0$, 180° should be added to θ .

If a vector \mathbf{A} makes an angle θ with the positive x-axis, then the horizontal and vertical components of the vector are given by $A_x = A \cos(\theta)$ and $A_y = A \sin(\theta)$.

Example: Consider the charged objects shown in the figure below. Object A has a charge of 5 nC. Object B has a charge of -3 nC. Object C has a charge of 2 nC.

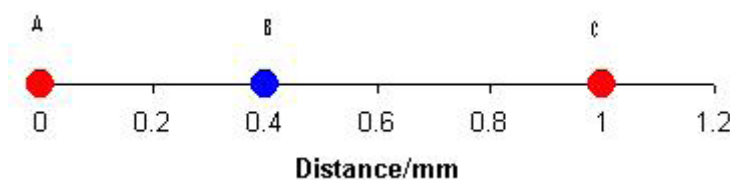

Figure 1.2

- a) Determine the magnitude and direction of the electrical force exerted by object A on object C.

Solution: Since object A and B have similar charges (positive), the force between them is repulsive. Therefore the force exerted by A on C is east (right).

$$q_A = 5 \text{ nC} = 5e-9 \text{ C} ; q_C = 2 \text{ nC} = 2e-9 \text{ C} ; r_{AC} = 1 \text{ mm} = 1e-3 \text{ m} ; F_{CA} = ?$$

$$F_{CA} = k|q_A||q_C|/r_{AC}^2 = 9e9 * 5e-9 * 2e-9 / (1e-3)^2 \text{ N} = 0.09 \text{ N}$$

b) Determine the magnitude and direction of the electrical force exerted by object B on object C.

Solution: Since object B and C have opposite charges, the force between them is attractive. Therefore the force exerted by B on C is west (left).

$$q_B = -3 \text{ nC} = -3e-9 \text{ C} ; q_C = 2 \text{ nC} = 2e-9 \text{ C} ; r_{BC} = 0.6 \text{ mm} = 0.6e-3 \text{ m} ; F_{CB} = ?$$

$$F_{CB} = k|q_B||q_C|/r_{BC}^2 = 9e9 * 3e-9 * 2e-9 / (0.6e-3)^2 \text{ N} = 0.15 \text{ N}$$

© 2013 Accenture. All rights reserved.

be > your degree

Bring your talent and passion to a global organization at the forefront of business, technology and innovation. Discover how great you can be.

Visit accenture.com/bookboon

Be greater than.
consulting | technology | outsourcing

accenture
High performance. Delivered.

- c) Determine the magnitude and direction of the net electrical force exerted on C by A and B.

Solution: According to the superposition principle, the net force exerted on C is the vector sum of the forces exerted by A and B: The two forces have the same line of action (horizontal) and are opposite in direction. Thus the net force is the difference between the two forces and takes the direction of the bigger force. The bigger force is force due to B. Therefore the net force will take the direction of the force due to B which is west.

$$\mathbf{F}_{net} = (F_{CB} - F_{CA}) \text{ west} = (0.15 - 0.09) \text{ N west} = 0.06 \text{ N west.}$$

Example: Consider the charged objects shown below. Object A has a charge of $-5 \mu\text{C}$, Object B has a charge of $-2 \mu\text{C}$ and Object C has a charge of $3 \mu\text{C}$.

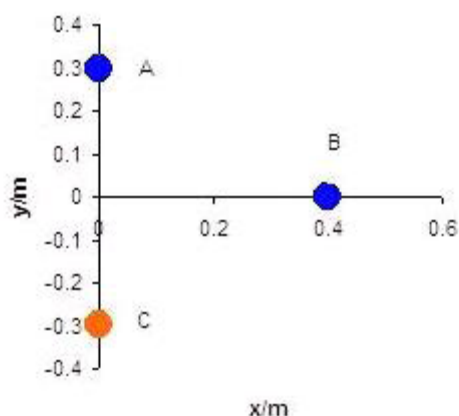

Figure 1.3

- a) For the electrical force exerted by object A on object B
- Calculate the magnitude and direction of the force.

Solution: Since both objects have similar charges, the force exerted by A on B is repulsive. The angle formed between this force and the positive x-axis (horizontal line to the right of B) is numerically equal to the angle formed at B in the right angled triangle formed by A, B and the origin (because they are vertically opposite angles). Also the angle should be negative because it is measured in a clockwise direction from the positive x-axis. Therefore this angle can be calculated from the sides of the right angled triangle formed by the origin, A and B.

$$q_A = -5 \mu\text{C} = -5e-6 \text{ C}; q_B = -2 \mu\text{C} = -2e-6 \text{ C}; r_{BA} = \sqrt{(0.3^2 + 0.4^2)} \text{ m} = 0.5 \text{ m};$$

$$\theta_{BA} = ?; F_{BA} = ?$$

$$\theta_{BA} = -\arctan(0.3/0.4) = -36.9^\circ$$

$$F_{BA} = k|q_A||q_B|/r_{BA}^2 = 9e9 * |-5e-6| * |-2e-6|/0.5^2 \text{ N} = 0.36 \text{ N}$$

ii. Calculate the x and y-components of the force.

Solution: $F_{BAx} = ?; F_{BAy} = ?$

$$F_{BAx} = F_{BA} \cos(\theta_{BA}) = 0.36 * \cos(-36.9^\circ) \text{ N} = 0.29 \text{ N}$$

$$F_{BAy} = F_{BA} \sin(\theta_{BA}) = 0.36 * \sin(-36.9^\circ) \text{ N} = -0.22 \text{ N}$$

b) For the electrical force exerted by object C on object B

i. Calculate the magnitude and direction of the force.

Solution: Since objects B and C have opposite charges, the force is attractive and is directed towards C. The angle made by this force with respect to the positive x-axis (horizontal line to the right of B) is 180° plus the angle formed at B in the right angled triangle formed by B, C and the origin (which can be calculated from the sides of the right angled triangle)

$$q_B = 3 \mu\text{C} = 3e-6 \text{ C}; r_{BC} = \sqrt{(0.3^2 + 0.4^2)} = 0.5; \theta_{CA} = ?; F_{BC} = ?$$

$$\theta_{BC} = 180 + \arctan(0.3/0.4) = 216.9^\circ$$

$$F_{BC} = k|q_B||q_C|/r_{BC}^2 = 9e9 * |3e-6||-2e-6|/0.5^2 \text{ N} = 0.22$$

ii. Calculate the x and y-components of the force.

Solution: $F_{BCx} = ?; F_{BCy} = ?$

$$F_{BCx} = F_{BC} \cos(\theta_{BC}) = 0.22 * \cos(216.9^\circ) \text{ N} = -0.18 \text{ N}$$

$$F_{BCy} = F_{BC} \sin(\theta_{BC}) = 0.22 * \sin(216.9^\circ) \text{ N} = -0.13 \text{ N}$$

- c) For the net electrical force exerted on object B by objects A and C.
i. Calculate the horizontal and vertical components of the force.

Solution: $F_{netx} = ?$; $F_{nety} = ?$

$$F_{netx} = F_{BAx} + F_{BCx} = (0.29 + -0.18) \text{ N} = 0.11 \text{ N}$$

$$F_{nety} = F_{BAy} + F_{BCy} = (-0.22 + (-0.13)) \text{ N} = -0.35 \text{ N}$$

- ii. Calculate the magnitude and direction of the force.

Solution: $F_{net} = ?$; $\theta_{net} = ?$

$$F_{net} = \sqrt{(F_{netx})^2 + (F_{nety})^2} = \sqrt{(0.11)^2 + (-0.35)^2} \text{ N} = 0.37 \text{ N}$$

$$\theta_{net} = \arctan (F_{nety} / F_{netx}) = \arctan (-0.35 / 0.11) = -72.6^\circ$$

The Wake

the only emission we want to leave behind

Low-speed Engines Medium-speed Engines Turbochargers Propellers Propulsion Packages PrimeServ

The design of eco-friendly marine power and propulsion solutions is crucial for MAN Diesel & Turbo. Power competencies are offered with the world's largest engine programme – having outputs spanning from 450 to 87,220 kW per engine. Get up front! Find out more at www.mandieselturbo.com

Engineering the Future – since 1758.

MAN Diesel & Turbo



1.5 PRACTICE QUIZ 1.1

Choose the best answer. Answers can be found at the back of the book.

1. What is the unit of measurement for charge?
 - A. Ampere
 - B. Coulomb
 - C. Watt
 - D. Volt
 - E. Newton

2. Which of the following is not a correct statement?
 - A. Conduction is a charging process where a neutral object is brought in contact with a charged object.
 - B. Induction is a charging process where a neutral object is brought closer to a charged object and then grounded.
 - C. Insulators are substances without free electrons.
 - D. An object charged by conduction acquires a charge opposite to that of the charging object.
 - E. Opposite charges attract while similar charges repel.

3. A positive charge **A** is placed on the x-axis at $x = 11$ m. A negative charge **B** is placed on the x-axis at $x = 10$ m. Determine the direction of the electrical force exerted by charge **A** on charge **B**.
 - A. South
 - B. North
 - C. West
 - D. East
 - E. North east

4. A $3e-9$ C charge **A** is placed on the x-axis at $x = 0.009$ m. A $-4e-9$ C charge **B** is placed on the x-axis at $x = 0.004$ m. Determine the magnitude and direction of the electrical force exerted by charge **A** on charge **B**.
 - A. $4.32e-3$ N West
 - B. $3.888e-3$ N East
 - C. $3.888e-3$ N West
 - D. $3.456e-3$ N West
 - E. $4.32e-3$ N East

5. Object **A** of charge $-5e-6$ C is located on the x-axis at $x = 0.005$ m.
Object **B** of charge $-2e-6$ C is located on the x-axis at $x = 0.009$ m.
Object **C** of charge $3e-6$ C is located on the x-axis at $x = 0.012$ m.
Determine the magnitude and direction of the net electrical force exerted on object **C** by objects **A** and **B**.
- A. 9630.612 N West
 - B. 9630.612 N East
 - C. 8755.102 N West
 - D. 8755.102 N East
 - E. 10506.122 N East
6. Object **A** of charge $-2e-6$ C is located on the x-axis at $x = 0.002$ m.
Object **B** of charge $5e-6$ C is located on the x-axis at $x = 0.009$ m.
Object **C** of charge $-3e-6$ C is located on the x-axis at $x = 0.014$ m.
Determine the magnitude and direction of the net electrical force exerted on object **C** by objects **A** and **B**.
- A. 5025 N West
 - B. 5025 N East
 - C. 5023.9 N West
 - D. 5027.2 N West
 - E. 5023.9 N East
7. Object **A** of charge $3e-6$ C is located at the origin of a coordinate plane.
Object **B** of charge $5e-6$ C is located on the x-axis of a coordinate plane at $x = 0.002$ m.
Object **C** of charge $-4e-6$ C is located on the y-axis of a coordinate plane at $y = 0.002$ m.
Calculate the direction (angle formed with the positive x-axis) of the net electrical force exerted on object **A** by objects **B** and **C**.
- A. 113.072°
 - B. 127.206°
 - C. -34.794°
 - D. 141.34°
 - E. 38.66°

8. Object **A** of charge $4e-6$ C is located at the origin of a coordinate plane.
Object **B** of charge $3e-6$ C is located on the x-axis of a coordinate plane at $x = 0.003$ m.
Object **C** of charge $-5e-6$ C is located on the y-axis of a coordinate plane at $y = 0.004$ m.
Calculate the magnitude of the net electrical force exerted on object **A** by objects **B** and **C**.
- A. 18093.663 N
B. 11514.149 N
C. 9869.27 N
D. 13159.027 N
E. 16448.784 N
9. Object **A** of charge $2e-6$ C is located on the x-axis of a coordinate plane at $x = 0.005$ m.
Object **B** of charge $-3e-6$ C is located on the y-axis of a coordinate plane at $y = 0.005$ m.
Object **C** of charge $-2e-6$ C is located on the y-axis of a coordinate plane at $y = -0.004$ m.
Calculate the magnitude of the net electrical force exerted on object **A** by objects **B** and **C**.
- A. 879.12 N
B. 1025.64 N
C. 1758.241 N
D. 1465.2 N
E. 1318.68 N

SMS from your computer

...Sync'd with your Android phone & number

FREE
30 days trial!

Go to

BrowserTexting.com

and start texting from
your computer!

 BrowserTexting

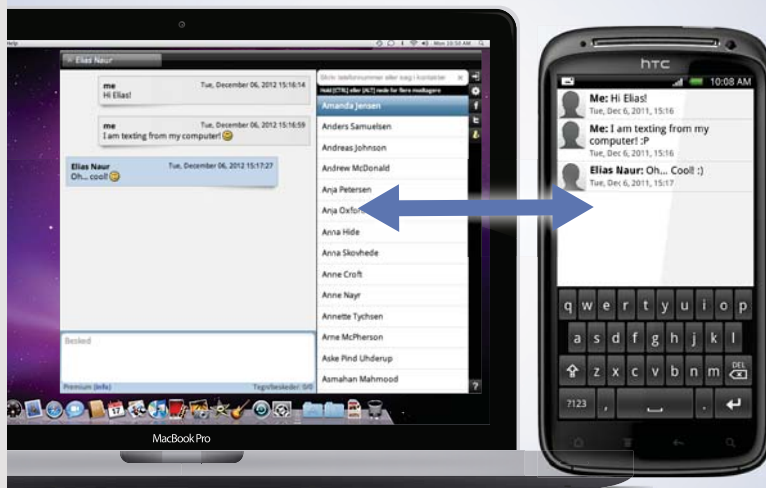

10. Object **A** of charge $4e-6$ C is located on the x-axis of a coordinate plane at $x = 0.004$ m.
Object **B** of charge $4e-6$ C is located on the y-axis of a coordinate plane at $y = 0.001$ m.
Object **C** of charge $-4e-6$ C is located on the y-axis of a coordinate plane at $y = -0.004$ m.
Calculate the direction (angle with respect to the positive x-axis) of the net electrical force exerted on object **A** by objects **B** and **C**.
- A. -47.464°
 - B. -48.66°
 - C. -42.396°
 - D. -41.378°
 - E. -46.119°

1.6 ELECTRIC FIELD

The force between charges can also be described in terms of fields by making use of field theory. *Field theory* states that a charge sets up electric field throughout space and this electric field exerts force on a charge placed at any point in space.

Electric field (E) at a given point is defined to be electric force (F) per a unit charge exerted on a charge (q) placed at the given point.

$$E = F/q$$

This is a vector equation. When the charge is positive the force and the field have the same direction; and when the charge is negative they have opposite directions. A relationship between the magnitudes of the electric force and electric field can be obtained equating the magnitudes of sides of the equation.

$$F = |q|E$$

F is the magnitude of the force exerted on a charge q placed at a point where the magnitude of the electric field is E . The unit of measurement for electric field is N/C.

Electric field at a certain point can be determined experimentally, by putting a small positive test charge on the point and then measuring the electric force acting on it. The electric field is obtained as the ratio between the magnitude of the force and the charge. The direction of the field will be the same as the direction of the force because the test charge is positive.

Example: Determine the magnitude and direction of an electric field at a certain point

- a) if a 4 C charge placed at the point experiences a force of 100 N north.

Solution: Since the charge is positive, the electric field should have the same direction as the force which is north.

$$q = 4\text{ C}; F = 100\text{ N}; E = ?$$

$$E = F/|q| = 100/4\text{ N/C} = 25\text{ N/C}$$

$$\mathbf{E} = 25\text{ N/C north}$$

- b) if a -5 C placed at the point experiences a force of 20 N west.

Solution: Since the charge is negative the direction of the electric field is opposite to that of the force. The direction of the force is west. Therefore the direction of the electric field must be east.

$$q = -5\text{ C}; F = 20\text{ N}; E = ?$$

$$E = F/|q| = 20/|-5|\text{ N/C} = 4\text{ N/C}$$

$$\mathbf{E} = 4\text{ N/C east}$$

Example: The electric field at a certain point is 20 N/C south.

- a) Calculate the magnitude and direction of the electric force acting on a -2 C charge placed at the point.

Solution: Since the charge is negative, the direction of the force is opposite to that of the field. The direction of the field is south. Therefore the direction of the force must be north.

$$q = -2 \text{ C}; E = 20 \text{ N/C}; F = ?$$

$$F = |q|E = |-2| * 20 \text{ N} = 40 \text{ N}$$

$$F = 40 \text{ N north}$$

b) Calculate the magnitude and direction of the force acting on a 4 C charge placed at the point.

Solution: Since the charge is positive the force has the same direction as the field which is south.

$$q = 4 \text{ C}; F = ?$$

$$F = |q|E = |4| * 20 \text{ N} = 80 \text{ N}$$

$$F = 80 \text{ N south}$$

**YOUR WORK AT TOMTOM WILL
BE TOUCHED BY MILLIONS.
AROUND THE WORLD. EVERYDAY.**

Join us now on www.TomTom.jobs

follow us on **LinkedIn**



#ACHIEVEMORE

TOMTOM 

1.7 ELECTRIC FIELD DUE TO A POINT CHARGE

Consider a small positive charge q_0 placed a distance r from a point charge q . Suppose the magnitude of the force acting on the test charge by the point charge is F . Then the magnitude of the electric field at the location of the test charge is given by $E = F/q_0$. But according to Coulomb's law, the force exerted by q on q_0 is given as $F = k|q|q_0/r^2$. Therefore the magnitude of the electric field due to a point charge q , at a distance r from the point charge is given as follows:

$$E = k|q|/r^2$$

The direction of the field is the same as the direction of the force exerted on a positive charge placed at the point. Thus if the point charge is positive, since the direction of the force exerted on a positive charge placed at the point is repulsive, the direction of the field is away from the point charge along the line joining the point charge and the point. And if the point charge is negative, since the force on a positive charge placed at the point is attractive, the direction of the field is towards the point charge along the line joining the point charge and the point.

Example: Consider the diagram shown. Object A has a charge of -5 nC. Calculate the magnitude and direction of the electric field at point P.

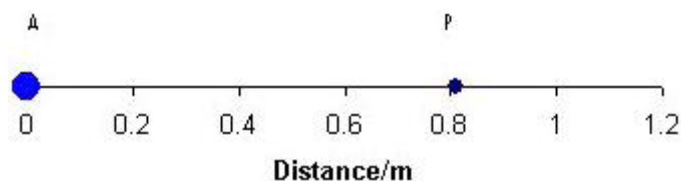

Figure 1.4

Solution: Since the charge is negative, the direction of the electric field is directed towards the charge along the line joining the point and the charge. Thus the direction of the electric field at point P is west.

$$q = -5 \text{ nC} = -5 \times 10^{-9} \text{ C}; r = 0.8 \text{ m}; E = ?$$

$$E = k|q|/r^2 = 9 \times 10^9 * 5 \times 10^{-9} / 0.8^2 \text{ N/C} = 70.3 \text{ N/C}$$

$$E = 70.3 \text{ N/C west}$$

1.8 SUPERPOSITION PRINCIPLE FOR ELECTRIC FIELD

The *superposition principle for electric field* states that if there are a number of charges in the vicinity of a point, then the net electric field at the point is the vector sum of all the electric fields due to the individual charges. If charges $q_1, q_2 \dots q_n$ are in the vicinity of a point, then the net electric field (E_{net}) is given as

$$\mathbf{E}_{net} = \mathbf{E}_1 + \mathbf{E}_2 + \dots + \mathbf{E}_n$$

where $\mathbf{E}_1, \mathbf{E}_2 \dots \mathbf{E}_n$ are electric fields due to charges $q_1, q_2 \dots q_n$ respectively.

Example: Consider the diagram shown below. Object A has a charge of -6 nC. Object B has a charge of 4 nC. Determine the magnitude and direction of the net electric field at point P.

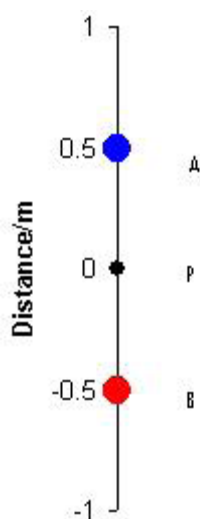

Figure 1.5

Solution: The net electric field at point P is the vector sum of the electric fields due to objects A and B. Since the charge of A is negative, the direction of the electric field at point P is directed towards itself; and thus its direction is north. Since charge B is positive, the direction of the electric field at point P due to B is directed away from B; that is its direction is north. Since both fields have the same direction, the net field has the same direction as both (north) and its magnitude is obtained by adding the magnitudes of both vectors.

$$q_A = -6 \text{ nC} = -6e-9 \text{ C} ; r_A = 0.5 \text{ m} ; q_B = 4 \text{ nC} = 4e-9 \text{ C} ; r_B = 0.5 \text{ m} ; \mathbf{E}_{net} = \mathbf{E}_A + \mathbf{E}_B = ?$$

$$E_A = k|q_A|/r_A^2 = 9e9 * 6e-9/0.5^2 \text{ N/C} = 216 \text{ N/C}$$

$$\mathbf{E}_A = 216 \text{ N/C north}$$

$$E_B = k|q_B|/r_B^2 = 9e9 * 4e-9/0.5^2 \text{ N/C} = 144 \text{ N/C}$$

$$\mathbf{E}_B = 144 \text{ N/C north}$$

$$\mathbf{E}_{net} = \mathbf{E}_A + \mathbf{E}_B = (E_A + E_B) \text{ N/C north} = (216 + 144) \text{ N/C north} = 356 \text{ N/C north}$$



Brain power

By 2020, wind could provide one-tenth of our planet's electricity needs. Already today, SKF's innovative know-how is crucial to running a large proportion of the world's wind turbines.

Up to 25 % of the generating costs relate to maintenance. These can be reduced dramatically thanks to our systems for on-line condition monitoring and automatic lubrication. We help make it more economical to create cleaner, cheaper energy out of thin air.

By sharing our experience, expertise, and creativity, industries can boost performance beyond expectations. Therefore we need the best employees who can meet this challenge!

The Power of Knowledge Engineering

Plug into The Power of Knowledge Engineering.
Visit us at www.skf.com/knowledge



Example: Consider the charges shown. Object A has a charge -8 nC . Object B has a charge of 3 nC .

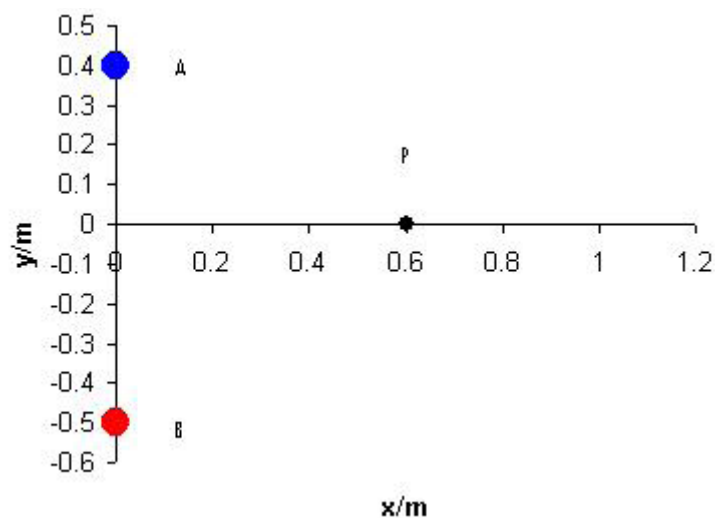

Figure 1.6

- a) Calculate the horizontal and vertical components of the net electric field at point P.

Solution: Since the charge of A is negative the direction of the electric field at point P due to A is directed towards A. The default angle for this vector (angle with respect to the horizontal line to the right) can be obtained by subtracting the angle formed at point P in the right angled triangle formed by A, P and the origin from 180° . Since the charge of B is positive the direction of the electric field at point P due to B is directed away from B. The default angle for this vector is equal to the angle formed at point P in the right angled triangle formed by B, P and the origin.

$$q_A = -8 \text{ nC} = -8e-9 \text{ C}; r_{AP} = \sqrt{(0.4^2 + 0.6^2)} \text{ m} = 0.72 \text{ m}; \theta_A = 180^\circ - \arctan(0.4/0.6) = 146.3^\circ; q_B = 3 \text{ nC} = 3e-9 \text{ C}; r_{BP} = \sqrt{(0.5^2 + 0.6^2)} \text{ m} = 0.78 \text{ m}; \theta_B = \arctan(0.5/0.6) = 39.8^\circ; E_{netx} = E_{Ax} + E_{Bx} = ?; E_{nety} = E_{Ay} + E_{By} = ?$$

$$E_A = k|q_A|/r_{Ap}^2 = 9e9 * 8e-9/0.72^2 \text{ N/C} = 138.9 \text{ N/C}$$

$$E_B = k|q_B|/r_{Bp}^2 = 9e9 * 3e-9/0.78^2 \text{ N/C} = 44.4 \text{ N/C}$$

$$E_{netx} = E_{Ax} + E_{Bx}$$

$$E_{netx} = E_A \cos(\theta_A) + E_B \cos(\theta_B) = \{138.9 * \cos(146.3^\circ) + 44.4 * \cos(39.8^\circ)\} \text{ N/C} = -81.4 \text{ N/C}$$

$$E_{nety} = E_{Ay} + E_{By}$$

$$E_{nety} = E_A \sin(\theta_A) + E_B \sin(\theta_B) = \{138.9 * \sin(146.3^\circ) + 44.4 * \sin(39.8^\circ)\} \text{ N/C} \\ = 105.5 \text{ N/C}$$

b) Calculate the magnitude and direction of the net electric field at point P.

Solution: $E_{net} = ? ; \theta_{net} = ?$

$$E_{net} = \sqrt{(E_{netx}^2 + E_{nety}^2)} = \sqrt{((-81.4)^2 + 105.5^2)} \text{ N/C} = 133.3 \text{ N/C}$$

$$\theta_{net} = \arctan \{105.5 / (-81.4)\} + 180^\circ = 127.7^\circ$$

1.9 ELECTRIC FIELD LINES

Electric field lines are lines used to represent electric field. Since electric field is a vector quantity, electric field lines should represent both magnitude and direction of the field. The magnitude of the field is represented by the number of lines per a unit perpendicular area (density of lines). The number of lines per a unit perpendicular area is drawn in such a way that it is proportional to the magnitude of the field. The line of action of the field at a point on a line is represented by the line tangent to the curve at the given point. To distinguish between the two possible directions of the tangent line, an arrow is put on the lines.

Electric field lines originate in a positive charge and sink in a negative charge somewhere. The arrows are directed from the positive charge towards the negative charge. Electric field lines cannot cross each other. Because if they do, that would mean two tangent lines or two directions at the intersection point and there can't be two directions for a given field.

1.10 ELECTRIC FIELD LINES DUE TO POINT CHARGES

The electric field lines due to a positive point charge (Assuming the negative charge is at infinity) originate from the positive charge (the arrows are directed away from the charge) and spread out radially. The following diagram shows electric field lines due to a positive point charge.

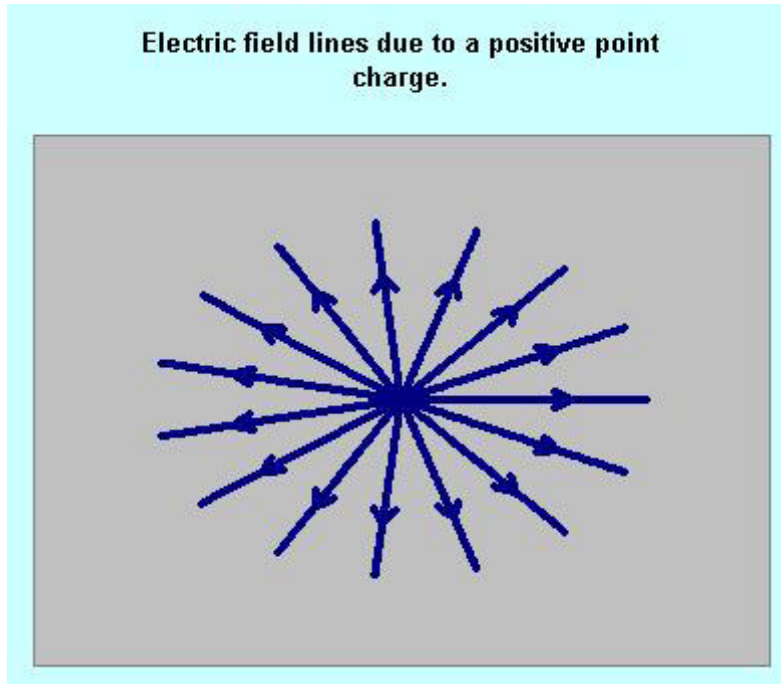

Figure 1.7

An advertisement for the AXA Global Graduate Program 2015. The left side of the ad features a close-up portrait of a young woman with red hair, smiling slightly. The right side is white with blue text and graphics. A red diagonal line separates the two sections. The text includes a call to action, the program name, and the AXA logo.

> Apply now

REDEFINE YOUR FUTURE
**AXA GLOBAL GRADUATE
PROGRAM 2015**

redefining / standards 

agence.cdg - © Photonostop

The electric field lines due to a negative point charge (assuming the positive charge is at infinity) sink (the arrows are directed towards the charge) into the charge radially. The following diagram shows electric field lines due a negative point charge.

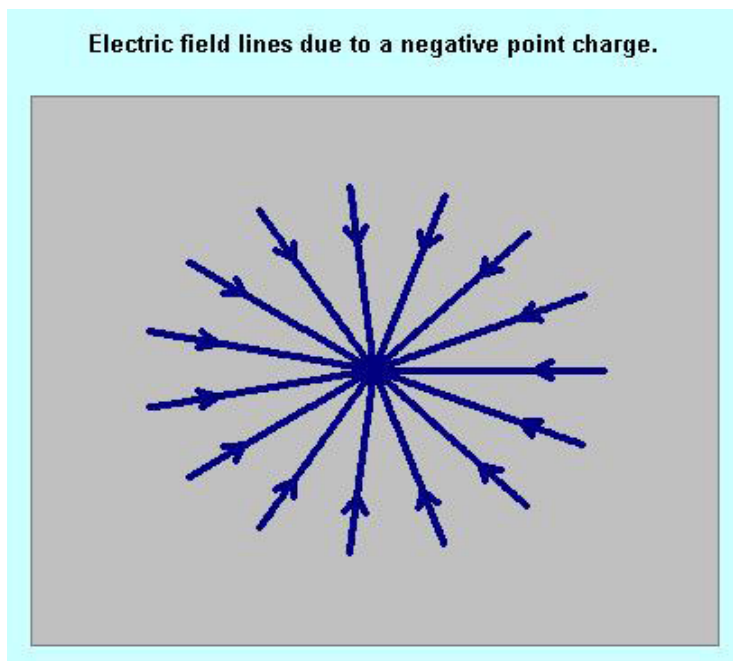

Figure 1.8

The electric field lines due to a positive and a negative charge originate in the positive charge and sink in a negative charge (the arrows are directed from the positive charge towards the negative charge). The following diagram shows electric field lines due to a positive and a negative point charges.

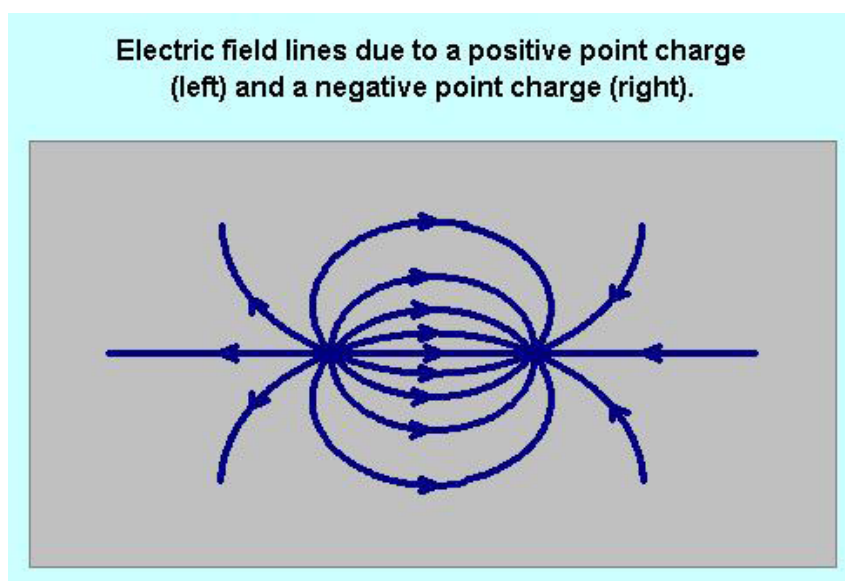

Figure 1.9

The electric field lines due to two positive point charges originate from both charges and go outward. The following diagram shows electric field lines due to two positive point charges.

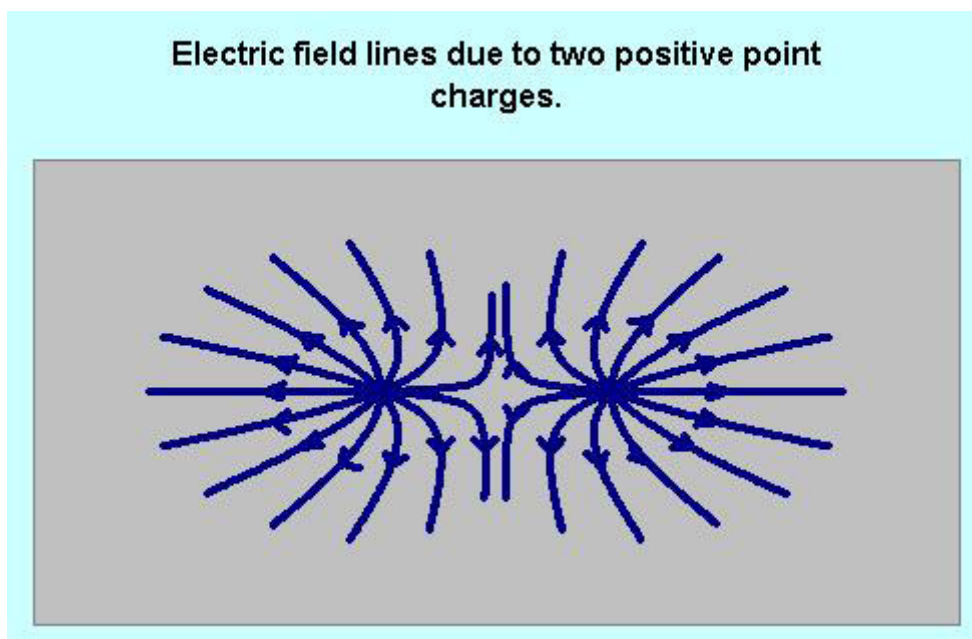

Figure 1.10

The electric field lines due to two negative point charges sink into both charges. The following diagram shows electric field lines due to two negative point charges.

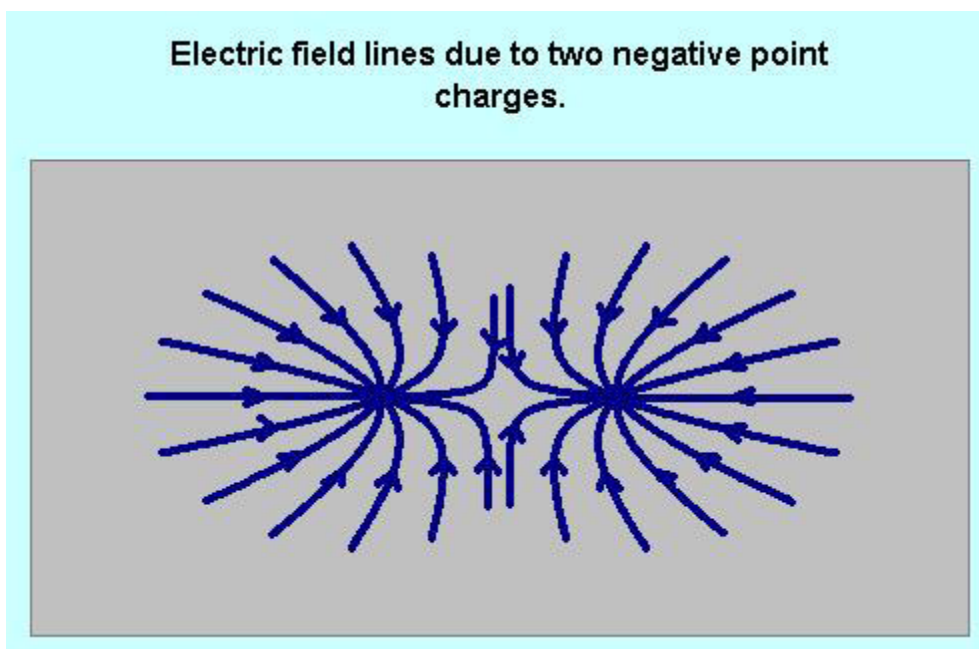

Figure 1.11

1.11 PRACTICE QUIZ 1.2

Choose the best answer. Answers can be found at the back of the book.

1. Which of the following is a correct statement?
 - A. The magnitude of the electric field due to a point charge is inversely proportional to the square of the distance between the charge and the point.
 - B. The direction of the electric force on a positive charge is opposite to the direction of the electric field at its location.
 - C. The direction of the electric field due to a negative point charge is directed away from the charge.
 - D. There is no electric field at a point where there is no charge.
 - E. The unit of measurement for electric field is Joule / Coulomb.
2. Which of the following is a correct statement?
 - A. The line of action of an electric field at a given point is perpendicular to the line tangent to the electric field line at the given point.
 - B. The denser the electric field lines, the smaller the magnitude of the electric field.
 - C. Electric field lines originate from a positive charge and sink in a negative charge.
 - D. The electric field lines due to a positive charge are directed towards the charge.
 - E. It is possible for electric field lines to cross each other.

LIGS University based in Hawaii, USA

is currently enrolling in the
Interactive Online **BBA, MBA, MSc,**
DBA and PhD programs:

- ▶ enroll **by October 31st, 2014** and
- ▶ **save up to 11%** on the tuition!
- ▶ pay in 10 installments / 2 years
- ▶ Interactive **Online education**
- ▶ visit www.ligsuniversity.com to
find out more!

**Note: LIGS University is not accredited by any
nationally recognized accrediting agency listed
by the US Secretary of Education.
More info [here](#).**



3. Calculate the magnitude and direction of the electric field at a point where a 6 C charge experiences a force of 85 N north.
- A. 12.75 N/C north
 - B. 14.167 N/C south
 - C. 12.75 N/C south
 - D. 17 N/C west
 - E. 14.167 N/C north
4. A $-3e-9\text{ C}$ charge **A** is placed on the x-axis at $x = 0.9\text{ m}$. Point **P** is located on the x-axis at $x = 0.8\text{ m}$. Determine the magnitude and direction of the electric field at point **P** due to charge **A**.
- A. 2970 N/C West
 - B. 2700 N/C West
 - C. 2700 N/C East
 - D. 2970 N/C East
 - E. 2160 N/C West
5. Object **A** of charge $2e-9\text{ C}$ is located on the x-axis at $x = 0.3\text{ m}$.
Object **B** of charge $1e-9\text{ C}$ is located on the x-axis at $x = 1\text{ m}$.
Point **P** is located on the x-axis at $x = 1.3\text{ m}$.
Determine the magnitude and direction of the net electric field at point **P** due to objects **A** and **B**.
- A. 118 N/C East
 - B. 129.8 N/C West
 - C. 129.8 N/C East
 - D. 141.6 N/C West
 - E. 118 N/C West
6. Object **P** is located on the x-axis at $x = 0.3\text{ m}$.
Object **A** of charge $-2e-9\text{ C}$ is located on the x-axis at $x = 0.8\text{ m}$.
Object **B** of charge $2e-9\text{ C}$ is located on the x-axis at $x = 1.2\text{ m}$.
Determine the magnitude and direction of the net electric field at point **P** due to objects **A** and **B**.
- A. 50.778 N/C East
 - B. 49.778 N/C East
 - C. 50.778 N/C West
 - D. 49.778 N/C West
 - E. 51.778 N/C East

7. Point **P** is located at the origin of a coordinate plane.
Object **A** of charge $-4e-9$ C is located on the x-axis of a coordinate plane at $x = 0.5$ m.
Object **B** of charge $2e-9$ C is located on the y-axis of a coordinate plane at $y = 0.4$ m.
Calculate the direction (angle formed with the positive x-axis) of the net electric field at point **P** due to objects **A** and **B**.
- A. 156.201°
B. 142.001°
C. -37.999°
D. 170.402°
E. -41.799°
8. Point **P** is located at the origin of a coordinate plane.
Object **A** of charge $4e-9$ C is located on the x-axis of a coordinate plane at $x = 0.5$ m.
Object **B** of charge $-3e-9$ C is located on the y-axis of a coordinate plane at $y = 0.5$ m.
Calculate the magnitude of the net electric field at point **P** due to objects **A** and **B**.
- A. 252 N/C
B. 126 N/C
C. 198 N/C
D. 180 N/C
E. 216 N/C
9. Point **P** is located on the x-axis of a coordinate plane at $x = 0.5$ m.
Object **A** of charge $1e-9$ C is located on the y-axis of a coordinate plane at $y = 0.2$ m.
Object **B** of charge $3e-9$ C is located on the y-axis of a coordinate plane at $y = -0.005$ m.
Calculate the magnitude of the net electric field at point **P** due to objects **A** and **B**.
- A. 82.318 N/C
B. 137.197 N/C
C. 109.757 N/C
D. 96.038 N/C
E. 150.917 N/C
10. Point **P** is located on the x-axis of a coordinate plane at $x = 0.2$ m.
Object **A** of charge $-2e-9$ C is located on the y-axis of a coordinate plane at $y = 0.3$ m.
Object **B** of charge $-3e-9$ C is located on the y-axis of a coordinate plane at $y = -0.2$ m.
Calculate the direction (angle with respect to the positive x-axis) of the net electric field at point **P** due to objects **A** and **B**.
- A. 196.971°
B. 200.271°
C. 201.371°
D. 199.171°
E. 204.671°

2 ELECTRICAL ENERGY AND CAPACITANCE

Your goals for this chapter are to learn about electrical energy, potential difference and capacitors.

2.1 ELECTRICAL ENERGY

The work (W) done by an electrical force in displacing a charge q is equal to the product of the magnitude of the electrical force (F), the magnitude of the displacement (d), and the cosine of the angle (θ) between the force and the displacement. The magnitude of the force is equal to the product of the absolute value of the charge and the magnitude of the electric field (E).

$$W_e = |q|Ed \cos(\theta)$$

If the electrical force and the displacement are parallel, then $\theta = 0$ and $W_e = |q|Ed$.

TURN TO THE EXPERTS FOR SUBSCRIPTION CONSULTANCY

Subscribe is one of the leading companies in Europe when it comes to innovation and business development within subscription businesses.

We innovate new subscription business models or improve existing ones. We do business reviews of existing subscription businesses and we develop acquisition and retention strategies.

Learn more at [linkedin.com/company/subscribe](https://www.linkedin.com/company/subscribe) or contact
Managing Director Morten Suhr Hansen at mha@subscribe.dk

SUBSCR✓**BE** - to the future

Electrical force is a conservative force. The work done by electrical force is independent of the path followed. It depends only on the electrical potential energies at the initial and final position. It is equal to the negative of the change in its potential energy.

$$W_e = -\Delta PE_e = -(PE_{ef} - PE_{ei})$$

PE_{ei} and PE_{ef} are the electrical potential energies at the initial and final locations respectively. If electrical force is the only force with non-zero contribution to the work done, then mechanical energy is conserved and the following equations hold.

$$KE_i + PE_{ei} = KE_f + PE_{ef}$$

$$\Delta KE = -\Delta PE_e$$

KE_i and KE_f are the kinetic energies at the initial and final locations respectively. ΔKE and ΔPE_e are equal to $(KE_f - KE_i)$ and $(PE_{ef} - PE_{ei})$ respectively. Since kinetic energy of an object of mass m and speed v is given as $mv^2/2$, these equations can be rewritten as follows.

$$mv_i^2/2 + PE_{ei} = mv_f^2/2 + PE_{ef}$$

$$mv_f^2/2 - mv_i^2/2 = -\Delta PE_e$$

v_i and v_f are the initial and final velocities respectively.

Example: The electric field between two oppositely charged parallel plates is perpendicular to the plates and is uniform. The magnitude of the electric field is 50 N/C . The plates are separated by a distance 0.002 m . A proton (charge = $1.6e-19 \text{ C}$, mass = $1.67e-27 \text{ kg}$) is released from rest at the negative plate.

- a) Calculate the work done by the electric force in displacing the proton from the positive plate to the negative plate.

Solution: Since the charge is positive, the electric force and the electric field are parallel. Therefore the electric force is directed from the positive plate to the negative plate perpendicularly. The displacement of the proton is also from the positive plate to the negative plate perpendicularly (because it is repelled by the positive plate and attracted by the negative plate). Thus the angle between the force and the displacement is zero.

$$E = 50 \text{ N/C}; d = 0.002 \text{ m}; q = 1.6e-19 \text{ C}; W_e = ?$$

$$W_e = |q|Ed = 1.6e-19 * 50 * 0.002 \text{ J} = 1.6e-20 \text{ J}$$

- b) Calculate the change in the potential energy of the proton as it is displaced from the positive plate to the negative plate.

Solution: $\Delta PE = ?$

$$\Delta PE = - W_e = - 1.6e-20 \text{ J}$$

- c) Calculate the speed with which the proton will hit the negative plate.

Solution: $v_i = 0$ (because released from rest); $m = 1.67e-27 \text{ kg}$; $v_f = ?$

$$mv_f^2/2 - mv_i^2/2 = - \Delta PE_e$$

$$v_f^2 = - 2\Delta PE_e / m$$

$$v_f = \sqrt{(- 2\Delta PE_e / m)} = \sqrt{(-2 * -1.6e-20 / 1.67e-27)} \text{ m/s} = 4377 \text{ m/s}$$

2.2 POTENTIAL DIFFERENCE

Potential Difference (ΔV) between two points is defined to be as the change in potential energy per a unit charge, for a charge transported between the two points; that is $\Delta V = \Delta PE_e / q$. Or

$$\Delta PE_e = q\Delta V$$

The unit of measurement for potential difference is J/C which is defined to be the Volt and abbreviated as V. For two oppositely charged parallel plates, since $|\Delta PE_e| = |q|Ed$ and $|\Delta V| = |\Delta PE_e/q|$, the absolute value of the potential difference between the plates is the product of the magnitude of the electric field and their separation.

$$|\Delta V| = Ed$$

Example: 4 mJ of energy is required to transport a $3 \mu\text{C}$ charge (with uniform velocity) between two points. Calculate the potential difference between the points.

Solution: Since it is transported with a uniform velocity, the work done by the external force to transport it and the work done by the electrical force must be numerically equal.

$$q = 3 \mu\text{C} = 3e-6 \text{ C}; \Delta PE_e = 4 \text{ mJ} = 4e-3 \text{ J}; \Delta V = ?$$

$$\Delta V = \Delta PE_e/q = 4e-3/3e-6 \text{ V} = 1.3e3 \text{ V}$$



"I studied English for 16 years but...
...I finally learned to speak it in just six lessons"

Jane, Chinese architect

ENGLISH OUT THERE

Click to hear me talking before and after my unique course download

Example: The electric field between two parallel oppositely charged plates separated by a distance of 0.004 m has a magnitude of 15 N/C. Calculate the potential difference between the plates.

Solution: $E = 15$ N/C; $d = 0.004$ m; $\Delta V = ?$

$$\Delta V = Ed = 15 * 0.004 \text{ V} = 0.06 \text{ V}$$

Example: Calculate

- a) the speed of a proton (charge = $1.6e-19$ C; mass = $1.67e-27$ kg) accelerated (from rest) through a potential difference of 100 V.

Solution: If electrical force is the only force acting on a positive charge, it is displaced towards lower potential (less positive or more negative) regions; that is, the potential difference of a positive charge under the influence of electrical force only should be negative.

$q = 1.6e-19$ C; $\Delta V = -100$ V; $v_i = 0$; $m = 1.67e-27$ kg; $v_f = ?$

$$mv_f^2/2 - mv_i^2/2 = -\Delta PE_e = -q\Delta V$$

$$v_f^2 = -2q\Delta V/m$$

$$v_f = \sqrt{-2q\Delta V/m} = \sqrt{-2 * 1.6e-19 * -100 / 1.67e-27} \text{ m/s} = 138426 \text{ m/s}$$

- b) the speed of an electron (charge = $-1.6e-19$ C; mass = $9.1e-31$ kg) accelerated (from rest) through a potential difference of 100 V.

Solution: If electrical force is the only force acting on a negative charge, it is displaced towards higher potential (more positive or less negative) regions; that is, the potential difference of a negative charge under the influence of electrical force only should be positive.

$q = -1.6e-19$ C; $\Delta V = 100$ V; $v_i = 0$; $m = 9.1e-31$ kg; $v_f = ?$

$$mv_f^2/2 - mv_i^2/2 = -\Delta PE_e = -q\Delta V$$

$$v_f^2 = -2q\Delta V/m$$

$$v_f = \sqrt{-2q\Delta V/m} = \sqrt{-2 * -1.6e-19 * 100 / 9.1e-31} \text{ m/s} = 5929995 \text{ m/s}$$

The **electron volt** (eV) is a unit of energy defined to be equal to the amount of energy required to accelerate an electron through a potential difference of one volt. Therefore it is equal to the product of the charge of an electron and one volt which is equal to $1.6e-19$ J.

$$1 \text{ eV} = 1.6e-19 \text{ J}$$

Electron volt is suitable for atomic physics because energies encountered in atomic physics are of the order of eV. For example, the ground state energy of the electron of a hydrogen atom is 13.6 eV.

Example: How many Joules are there in 50 eV?

Solution:

$$1 \text{ eV} = 1.6e-19 \text{ J}$$

$$1.6e-19 \text{ J} / \text{eV} = 1$$

$$50 \text{ eV} = 50 \text{ eV} * (1.6e-19 \text{ J} / \text{eV}) = 50 * 1.6e-19 \text{ J} = 50 * 1.6e-19 \text{ J} = 8e-18 \text{ J}$$

2.3 ELECTRIC POTENTIAL DUE TO A POINT CHARGE

Electric potential at a certain point is defined to be its potential difference with respect to a certain reference point where the potential is defined to be zero. The choice of a reference point is arbitrary. The reference point for the electric potential due to a point charge is usually taken to be at infinity. The potential of a point located a distance r from a point charge q with respect to infinity is given by the following equation.

$$V = kq/r$$

Where k is Coulombs constant ($k = 9e9 \text{ Nm}^2/\text{C}^2$). Electric potential due to a point charge can be positive or negative depending on whether the charge is positive or negative.

Example: Consider the diagram shown below. Charge A has a charge of -6 nC . Calculate the electric potential at point P due to charge A.

Solution: $q = -6 \text{ nC} = -6 \times 10^{-9} \text{ C}$; $r = 0.8 \text{ m}$; $V = ?$

$$V = kq/r = 9 \times 10^9 * -6 \times 10^{-9} / 0.8 \text{ V} = -67.5 \text{ V}$$

2.4 SUPERPOSITION PRINCIPLE FOR ELECTRIC POTENTIAL

Superposition Principle for electric potential states that if there are a number of charges in the vicinity of a point, then the net potential at the point is the algebraic sum of the potentials due to the individual charges. If charges q_1, q_2, \dots, q_n are in the vicinity of a point, then the net potential, V_{net} , at the point is given by

$$V_{net} = V_1 + V_2 + \dots + V_n$$

Where V_1, V_2, \dots, V_n are potentials due to charges q_1, q_2, \dots, q_n respectively.

wethrive.net

How to retain your top staff
FIND OUT NOW FOR FREE

DO YOU WANT TO KNOW:

- What your staff really want?
- The top issues troubling them?
- How to make staff assessments work for you & them, painlessly?

Get your free trial
Because happy staff get more done

Example: Consider the diagram shown below. Object A has a charge of -5 nC . Object B has a charge of 7 nC . Calculate the net potential at point P due to charges A and B.

Solution: $q_A = -5 \text{ nC} = -5e-9 \text{ C}$; $r_A = 0.5 \text{ m}$; $q_B = 7 \text{ nC} = 7e-9 \text{ C}$; $r_B = 0.5 \text{ m}$; $V_{net} = V_A + V_B = ?$

$$V_{net} = V_A + V_B = kq_A/r_A + kq_B/r_B = (9e9 * -5e-9/0.5 + 9e9 * 7e-9/0.5) \text{ V} = (-90 + 126) \text{ V} = 36 \text{ V}$$

2.5 ELECTRIC POTENTIAL ENERGY STORED BY TWO POINT CHARGES

Work is required to separate a positive and a negative charge (because they attract each other) or to bring similar charges closer (because they repel each other). This means there is energy stored by charges in the vicinity of each other equal to the work required to bring them to their locations. The energy stored by two charges separated by a certain distance is equal to the amount of work required to bring one of the charges from infinity to its location. The energy stored by two charges q_1 and q_2 separated by a distance r is equal to the amount of work required to bring the charge q_2 from infinity to its location. The work required to bring q_2 from infinity to its location is equal to $q_2 (V_2 - V_\infty)$. The potential at infinity, V_∞ , is zero because infinity is the reference point for potentials due to point charges. V_2 is the potential at the location of q_2 due to q_1 and is equal to kq_1/r . Therefore the energy (U) stored by two charges q_1 and q_2 separated by a distance r is given as follows:

$$U = kq_1q_2/r$$

The energy stored is positive if they have the same charges and negative if they are opposite charges.

Example: Calculate the electrical energy stored by a $3 \mu\text{C}$ charge and a $-9 \mu\text{C}$ charge separated by a distance of 0.006 m .

Solution: $q_1 = 3 \mu\text{C} = 3e-6 \text{ C}$; $q_2 = -9 \mu\text{C} = -9e-6 \text{ C}$; $r = 0.006 \text{ m}$; $U = ?$

$$U = kq_1q_2/r = 9e9 * 3e-6 * -9e-6/0.006 \text{ J} = -40 \text{ J}$$

2.6 CONDUCTORS IN ELECTROSTATIC EQUILIBRIUM

A Conductor is said to be in *electrostatic equilibrium* if its free charges are at rest. The electric field inside such a conductor must be zero because if it was not zero, the free charges would be moving. The work done in transporting a charge from one point inside such a conductor to another point must be zero because $W_e = |q|Ed \cos(\theta)$ and $E = 0$. And since the work done in taking a charge from one point to another is zero, it follows that all the points in a conductor in electrostatic equilibrium must be at the same potential because $\Delta V = \Delta PE_e/q = -W_e/q$ and $W_e = 0$. The work done in moving a charge along the surface of the conductor is zero because all the points on the surface are at the same potential. This implies that the electric field just outside a conductor must be perpendicular to the surface, because for displacements along the surface $W_e = |q|Ed \cos(\theta) = 0$ which is possible only if $\cos(\theta) = 0$ or $\theta = 90^\circ$.

2.7 EQUIPOTENTIAL SURFACES

An *equipotential surface* is a surface whose points are all at the same potential. Thus, no work is required in transporting a charge from one point to another point of an equipotential surface. Electric field lines and equipotential surfaces must be perpendicular to each other, because the work along an equipotential surface can be zero only if the electric field is perpendicular to the equipotential surfaces.

The following diagram shows equipotential and electric field lines due to a positive point charge.

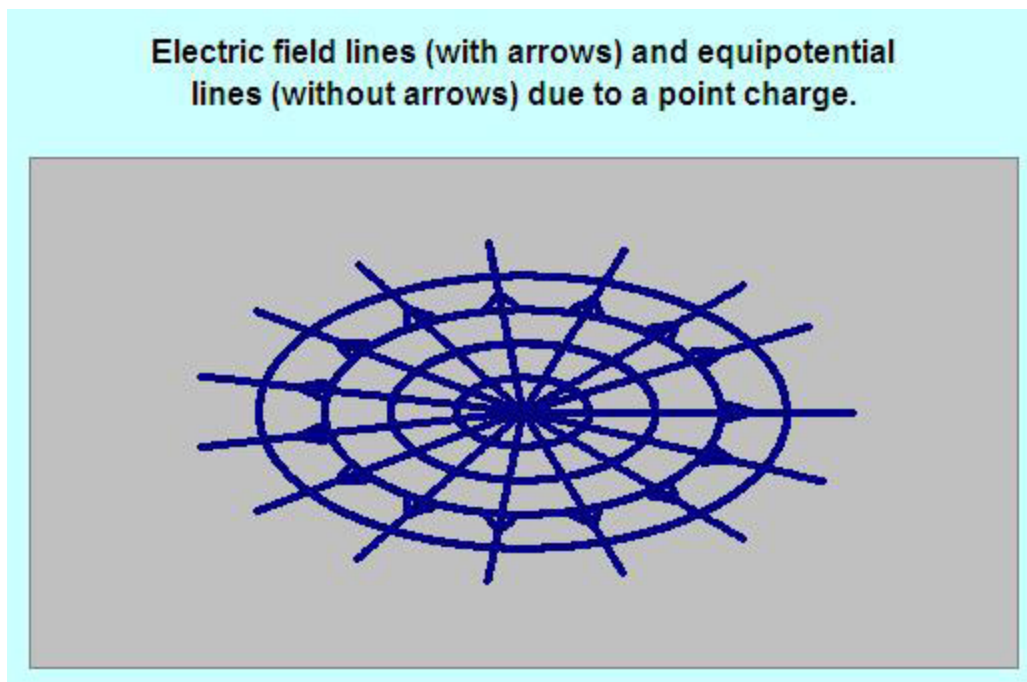

Figure 2.1

The following diagram shows equipotential and electric field lines due to a positive and a negative point charges.

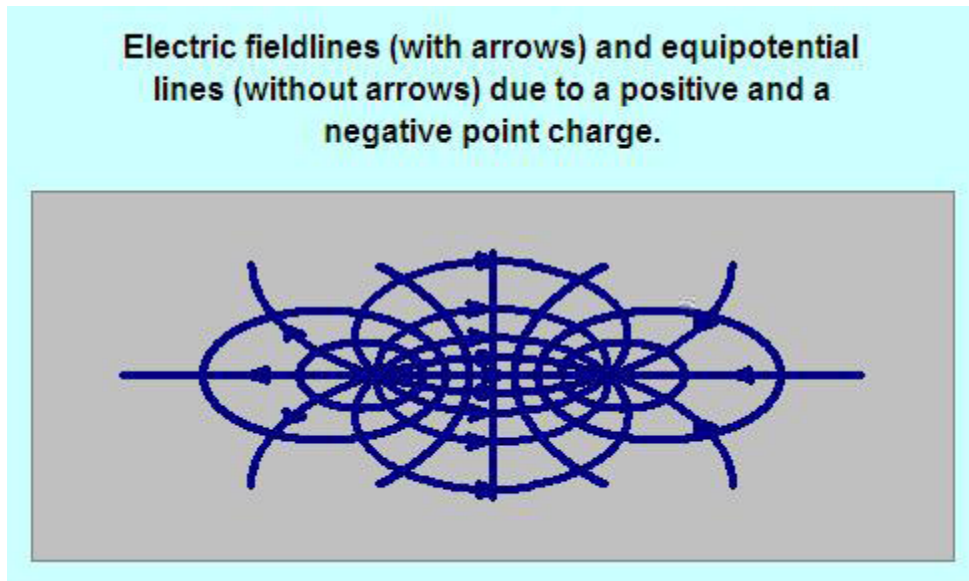

Figure 2.2

gaiTeye[®]
Challenge the way we run

**EXPERIENCE THE POWER OF
FULL ENGAGEMENT...**

.....

**RUN FASTER.
RUN LONGER..
RUN EASIER...**

**READ MORE & PRE-ORDER TODAY
WWW.GAITEYE.COM**

The advertisement features a runner in a red shirt and black leggings running on a path. The background is a bright, hazy sunset. Technical diagrams, including a circle with intersecting lines and a dotted line, are overlaid on the runner's feet.

The following diagram shows equipotential and electric field lines due to two positive point charges.

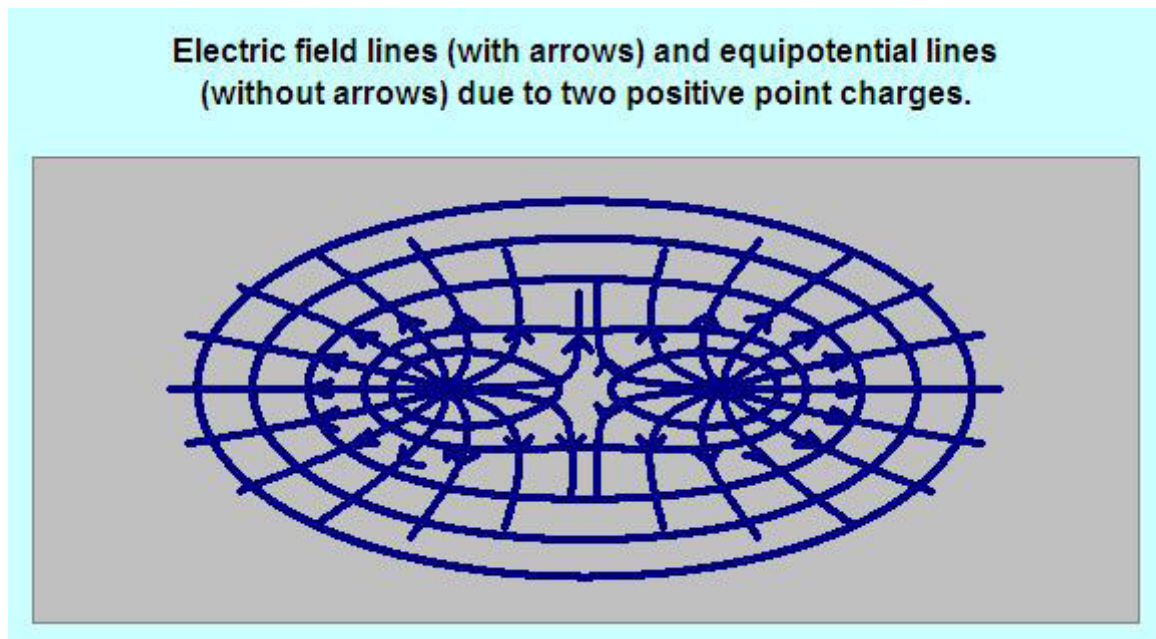

Figure 2.3

2.8 PRACTICE QUIZ 2.1

Choose the best answer. Answers can be found at the back of the book.

1. Which of the following is a correct statement?
 - A. Potential difference between two points is defined to be equal to the change in electrical potential energy of an electron displaced between the two points.
 - B. The unit of measurement for potential difference is the Joule.
 - C. Electron Volt (eV) is a unit of measurement of potential difference
 - D. The potential at a point due to a point charge is inversely proportional to the square of the distance between the point and the charge.
 - E. If the only force acting on an object is electrical force, then its mechanical energy is conserved.

2. Which of the following is a correct statement?
- A. A non-zero work is required to transport a charge from one point to another point of a conductor in electrostatic equilibrium.
 - B. No work is required to transport a charge from one point to another point of a conductor in electrostatic equilibrium.
 - C. The potential inside a conductor in electrostatic equilibrium may vary from point to point.
 - D. Electric field lines and equipotential surfaces are parallel to each other.
 - E. The electric field just outside a conductor in electrostatic equilibrium is parallel to the surface.
3. The electric field between two oppositely charged parallel plates has a strength of 500 N/C . If 430 J of work is required in displacing a 7 C charge from the positive to the negative plate, calculate the separation between the plates.
- A. 0.086 m
 - B. 0.172 m
 - C. 0.147 m
 - D. 0.123 m
 - E. 0.135 m
4. Two oppositely charged parallel plates are separated by a distance of 0.11 m . The strength of the electric field between the plates is 400 N/C . Calculate the change in electric potential energy of a(n) 7 C charge when displaced from the positive to the negative plate by the electric force.
- A. 338.8 J
 - B. 246.4 J
 - C. -308 J
 - D. 308 J
 - E. -338.8 J
5. A -0.15 C charge is displaced horizontally to the right with a distance of 0.2 m in a region where there is an electric field of strength 75 directed vertically upward. Calculate the work done by the electric force.
- A. 2.25 J
 - B. 0 J
 - C. 15 J
 - D. -15 J
 - E. -2.25 J

6. A 1.5 C charge is displaced by 0.32 m horizontally to the right in a region where there is an electric field of strength 200 N/C that makes an angle of 60° with the horizontal-right (east). Calculate the work done by the electric force.
- A. -48 J
 - B. -83.138 J
 - C. 96 J
 - D. 83.138 J
 - E. 48 J
7. The potential difference between two oppositely charged parallel plates is 17.1 V . If the strength of the electric field between the plates is 300 N/C , calculate the separation (distance) between the plates.
- A. 0.074 m
 - B. 0.057 m
 - C. 0.08 m
 - D. 0.068 m
 - E. 0.051 m

This e-book
is made with
SetaPDF

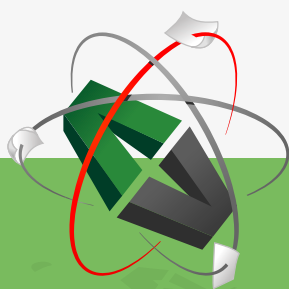

PDF components for PHP developers

www.setasign.com

8. If the electric potential energy of a 0.037 C charge displaced from point A to point B changes by 3.8 J , calculate the potential difference between point A and point B .
- A. 102.703 V
 - B. 92.432 V
 - C. 71.892 V
 - D. 123.243 V
 - E. 61.622 V
9. Calculate the speed of an object of mass $3e-11\text{ kg}$ and charge $5e-9\text{ C}$ accelerated from rest through a potential difference of 5 V .
- A. 53.072 m/s
 - B. 48.99 m/s
 - C. 24.495 m/s
 - D. 36.742 m/s
 - E. 40.825 m/s
10. Two oppositely charged parallel plates are separated by a distance of 0.175 m . The strength of the electric field between the plates is 325 N/C . An object of mass $2e-11\text{ kg}$ and charge $4e-9\text{ C}$ is released from rest at the positive plate. Calculate its speed by the time it reaches the negative plate.
- A. 120.665 m/s
 - B. 135.748 m/s
 - C. 105.582 m/s
 - D. 211.163 m/s
 - E. 150.831 m/s
11. A $-4e-9\text{ C}$ charge is located on the x-axis at $x = 0.3\text{ m}$.
A $1e-9\text{ C}$ charge is located on the x-axis at $x = 0.8\text{ m}$.
Calculate the net electric potential due to these charges at a point located on the x-axis at $x = 1.2\text{ m}$.
- A. -17.5 V
 - B. -16.389 V
 - C. -14.167 V
 - D. -13.056 V
 - E. -15.278 V

- 12.A $-4e-9$ C charge is located at the origin.
A $-4e-9$ C charge is located on the x-axis at $x = 0.8$ m.
Calculate the net electric potential due to these charges at a point located on the y-axis at $y = 1.1$ m.
- A. -60.306 V
 - B. -59.195 V
 - C. -62.528 V
 - D. -63.639 V
 - E. -56.973 V
13. How many Joules are there in 700 eV.
- A. $10.08e-17$
 - B. $5.25e21$
 - C. $4.375e21$
 - D. $11.2e-17$
 - E. $3.938e21$
14. Calculate the electrical energy stored between a $-6e-6$ C charge and a $1e-5$ C charge separated by a distance of 0.01 m.
- A. -48.6 J
 - B. 48.6 J
 - C. -0.54 J
 - D. 54 J
 - E. -54 J

2.9 CAPACITORS

A *capacitor* is two conductors separated by an insulator. A capacitor is used to store charges or electrical energy. When a capacitor is connected to a potential difference, electrons are transferred from one of the conductor to the other and both conductors acquire equal but opposite charges. The charge accumulated by a capacitor is directly proportional to the potential difference between the plates. The constant of proportionality (ratio) between the charge and the potential difference is called the capacitance (C) of the capacitor.

$$Q = C\Delta V$$

Q represents the charge accumulated by the capacitor and ΔV stands for the potential difference between the two conductors of the capacitor. The unit of measurement for capacitance is C/V which is defined to be the Farad and abbreviated as F. The following diagram shows the circuit symbol for a capacitor.



Figure 2.4

Example: Calculate the capacitance of a capacitor that stores a charge of 50 C when connected to a potential difference of 100 V .

Solution: $Q = 50\text{ C}$; $\Delta V = 100\text{ V}$; $C = ?$

$$Q = C \Delta V$$

$$C = Q/\Delta V = 50/100\text{ F} = 0.5\text{ F}$$



Discover the truth at www.deloitte.ca/careers

Deloitte.

© Deloitte & Touche LLP and affiliated entities.

The capacitance of a capacitor depends only on the geometry of the capacitor. For example the capacitance of a parallel plate capacitor depends only on the area of the plates and the separation between the plates. The capacitance of a parallel plate capacitor is directly proportional to the area of the plates and inversely proportional to the distance between the plates.

$$C_{\parallel} = \epsilon_0 A/d$$

C_{\parallel} is the capacitance of a parallel plate capacitor (in vacuum or approximately air) of area A separated by a distance d . ϵ_0 is a universal constant called electrical permittivity of vacuum. It is related with Coulomb's constant as $\epsilon_0 = 1/(4\pi k)$. Its value is $8.85e-12$ F/m.

Example: The plates of a parallel plate capacitor have an area of 0.0002 m². The two plates are separated by a distance of 0.03 m. If the capacitor is in air, calculate its capacitance.

Solution: $A = 0.0002$ m²; $d = 0.03$ m; $C_{\parallel} = ?$

$$C_{\parallel} = \epsilon_0 A/d = 8.8 \cdot 10^{-12} * 0.0002/0.03 \text{ F} = 5.9e-14 \text{ F}$$

2.10 ELECTRICAL ENERGY STORED BY A CAPACITOR

When the two conductors of a charged capacitor are connected by a conducting wire, charges will flow from one of the conductors to the other which indicates that there is stored electrical energy in a charged capacitor. As a capacitor is charged, the potential difference between the plates will increase linearly. This means the charges are not being transported through a constant potential difference. For a certain small charge dQ the change in potential energy (which is equal to the energy stored by the capacitor) is equal to the product of the charge dQ and the potential difference ΔV across which it was transported. Thus the energy (dU) stored in transporting this charge is given as $dU = dQ\Delta V$. These contributions from all the charges transported should be added to get the total energy stored. This sum can be obtained from the graph of potential difference versus charge as the area enclosed between the potential difference versus charge curve and the charge axis. Since the graph is linear, the total energy is equal to the area of a right angled triangle of base Q (total charge stored) and height ΔV (potential difference corresponding to the charge Q).

$$U = Q\Delta V/2$$

U stands for electrical energy stored by a capacitor of charge Q and potential difference ΔV . An expression for U in terms of capacitance and potential difference can be obtained by replacing Q by $C\Delta V$.

$$U = C\Delta V^2/2$$

Also, it can be expressed in terms of capacitance and charge by replacing ΔV by Q/C .

$$U = Q^2/(2C)$$

Example: Calculate the energy stored by a $2\ \mu\text{F}$ capacitor connected to a potential difference of $6\ \text{V}$

Solution: $C = 2\ \mu\text{F} = 2e-6\ \text{F}$; $\Delta V = 6\ \text{V}$; $U = ?$

$$U = C\Delta V^2/2 = 2e-6 * 6^2/2\ \text{J} = 3.6e-5\ \text{J}$$

2.11 PARALLEL COMBINATION OF CAPACITORS

Parallel connection is branched connection. The following diagram shows three capacitors connected in parallel.

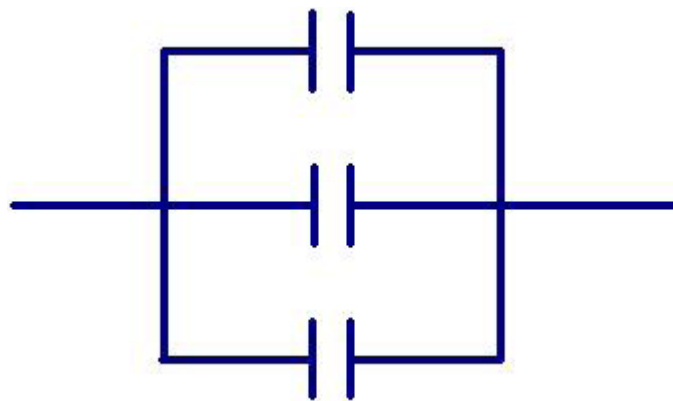

Figure 2.5

The parts of each capacitor that are connected by conducting wires are at the same potential because there is no potential drop across a conducting wire. This means capacitors connected in parallel have the same potential difference which is also equal to the total potential difference across the combination.

$$\Delta V = \Delta V_1 = \Delta V_2 = \Delta V_3 = \dots$$

$\Delta V_1, \Delta V_2, \Delta V_3 \dots$ are the potential differences across capacitors C_1, C_2, C_3, \dots connected in parallel. ΔV is the potential difference across the combination. The total charge accumulated by capacitors in parallel is equal to the sum of the charges of the individual capacitors.

$$Q = Q_1 + Q_2 + Q_3 + \dots$$

Q_1, Q_2, Q_3, \dots are charges accumulated by capacitors C_1, C_2, C_3, \dots connected in parallel. Q is the total charge accumulated by the combination.

Equivalent Capacitance of (C_{eq}) a combination of capacitors is the single capacitor that can replace the combination with the same effect. It is equal to the ratio between the total charge of the combination and the total potential difference across the combination.

$$C_{eq} = Q/\Delta V$$

© 2013 Accenture. All rights reserved.

be > your degree

Bring your talent and passion to a global organization at the forefront of business, technology and innovation. Discover how great you can be.

Visit accenture.com/bookboon

Be greater than.
consulting | technology | outsourcing

accenture
High performance. Delivered.

An expression for the equivalent capacitance of capacitors in parallel in terms of the capacitances can be obtained by starting from the fact that the total charge is equal to the sum of the individual charges, by replacing each charge with the product of its capacitance and potential difference, and by using the fact that all the potential differences are equal. After removing the common factor, potential difference, the following expression for the equivalent capacitance of capacitors connected in series can be obtained.

$$C_{eq} = C_1 + C_2 + C_3 + \dots$$

Example: A 40 F and a 60 F capacitor are connected in parallel and then connected to a potential difference of 20 V.

- a) Calculate the potential difference across each capacitor.

Solution: $\Delta V = 20 \text{ V}$; $\Delta V_1 = \Delta V_2 = ?$

$$\Delta V_1 = \Delta V_2 = \Delta V = 20 \text{ V}$$

- b) Calculate the charge accumulated by each capacitor.

Solution: $C_1 = 40 \text{ F}$; $C_2 = 60 \text{ F}$; $Q_1 = ?$; $Q_2 = ?$

$$Q_1 = C_1 \Delta V_1 = 40 * 20 \text{ C} = 800 \text{ C}$$

$$Q_2 = C_2 \Delta V_2 = 60 * 20 \text{ C} = 1200 \text{ C}$$

- c) Calculate their equivalent capacitance.

Solution: $C_{eq} = ?$

$$C_{eq} = (C_1 + C_2) = (40 + 60) \text{ F} = 100 \text{ F}$$

d) Calculate the total charge accumulated.

Solution: $Q = ?$

$$Q = Q_1 + Q_2 = (800 + 1200) \text{ C} = 2000 \text{ C}$$

Or

$$Q = C_{eq} \Delta V = 100 * 20 \text{ C} = 2000 \text{ C}$$

2.12 SERIES COMBINATION OF CAPACITORS

Series connection is connection in a single line. The following diagram shows the series combination of three capacitors.



Figure 2.6

When a series combination of capacitors is connected to a potential difference, charges will be transferred from one of the conductors directly connected to the potential difference to the other conductor connected directly to the potential difference. The other conductors are charged by induction. Thus the charges of all the capacitors are equal and they are equal to the total charge stored by the combination.

$$Q = Q_1 = Q_2 = Q_3 = \dots$$

Q_1, Q_2, Q_3, \dots are charges accumulated by capacitors C_1, C_2, C_3, \dots connected in series. Q is the total charge accumulated by the combination. The total potential difference across the combination is equal to the sum of the potential differences across the individual capacitors.

$$\Delta V = \Delta V_1 + \Delta V_2 + \Delta V_3 + \dots$$

$\Delta V_1, \Delta V_2, \Delta V_3, \dots$ are the potential differences across capacitors C_1, C_2, C_3, \dots connected in parallel. ΔV is the potential difference across the combination.

An expression for the equivalent capacitance of capacitors in series in terms of the capacitances can be obtained by starting from the fact that the total potential difference is equal to the sum of the individual potential differences, by replacing each potential difference with the ratio between its charge and its capacitance, and by using the fact that all the charges are equal. After removing the common factor, charge, the following expression for the equivalent capacitance of capacitors connected in series can be obtained.

$$1/C_{eq} = 1/C_1 + 1/C_2 + 1/C_3 + \dots$$

For two capacitors, this expression can be simplified by direct addition: $1/C_{eq} = (C_1 + C_2)/(C_1 C_2)$. And an expression for the equivalent capacitance can be obtained by inverting both sides of the equation.

$$C_{eq} = C_1 C_2 / (C_1 + C_2)$$

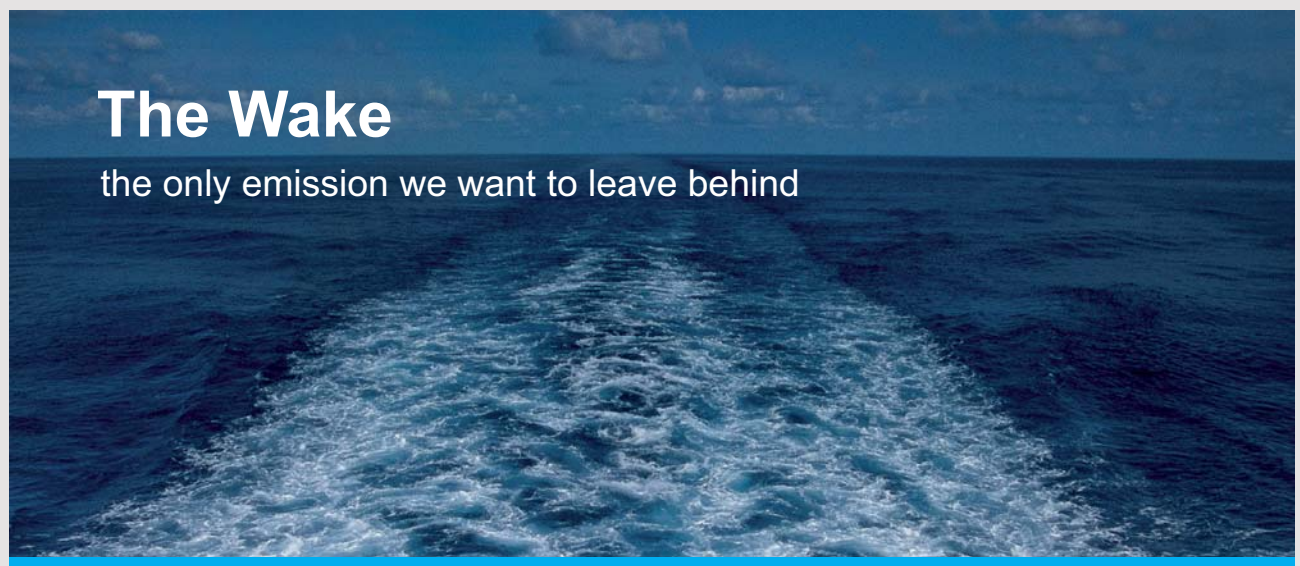

The Wake

the only emission we want to leave behind

Low-speed Engines Medium-speed Engines Turbochargers Propellers Propulsion Packages PrimeServ

The design of eco-friendly marine power and propulsion solutions is crucial for MAN Diesel & Turbo. Power competencies are offered with the world's largest engine programme – having outputs spanning from 450 to 87,220 kW per engine. Get up front! Find out more at www.mandieselturbo.com

Engineering the Future – since 1758.

MAN Diesel & Turbo



Example: A 20 F and a 30 F capacitors are connected in series and the combination is connected to a potential difference of 100 V.

- a) Calculate the equivalent capacitance of the combination.

Solution: $C_1 = 20 \text{ F}$; $C_2 = 30 \text{ F}$; $C_{eq} = ?$

$$C_{eq} = C_1 C_2 / (C_1 + C_2) = 20 * 30 / (20 + 30) = 12 \text{ F}$$

- b) Calculate the total charge accumulated by the combination.

Solution: $\Delta V = 100 \text{ V}$; $Q = ?$

$$Q = C_{eq} \Delta V = 12 * 100 \text{ C} = 1200 \text{ C}$$

- c) Calculate the charge accumulated by each capacitor.

Solution: $Q_1 = ?$; $Q_2 = ?$

$$Q_1 = Q_2 = Q = 1200 \text{ C}$$

- d) Calculate the potential difference across each capacitor.

Solution: $\Delta V_1 = ?$; $\Delta V_2 = ?$

$$\Delta V_1 = Q_1 / C_1 = 1200 / 20 \text{ V} = 60 \text{ v}$$

$$\Delta V_2 = Q_2 / C_2 = 1200 / 30 \text{ V} = 40 \text{ v}$$

2.13 PARALLEL-SERIES COMBINATION OF CAPACITORS

If a combination involves a number of parallel and series combinations, the combination can be simplified by replacing each parallel or series combination by its equivalent capacitor. This process can be repeated on the resulting combination again and again until the whole combination is represented by a single equivalent capacitor.

Example: An $8\ \mu\text{F}$ capacitor and a $5\ \mu\text{F}$ capacitors are connected in parallel and this combination is connected in series with a $2\ \mu\text{F}$ capacitor. Then the whole combination is connected to a potential difference of $8\ \text{V}$.

- a) Calculate the equivalent capacitance of the combination.

Solution: First the equivalent capacitance ($C_{1,2}$) of the capacitors connected in parallel should be obtained. Then this equivalent capacitance should be combined in series with the capacitance of the third capacitor.

$$C_1 = 8\ \mu\text{F} = 8e-6\ \text{F}; C_2 = 5\ \mu\text{F} = 5e-6\ \text{F}; C_3 = 2\ \mu\text{F} = 2e-6\ \text{F}; C_{eq} = ?$$

$$C_{1,2} = C_1 + C_2 = (8e-6 + 5e-6)\ \text{F} = 13e-6\ \text{F}$$

$$C_{eq} = C_{1,2} C_3 / (C_{1,2} + C_3) = 13e-6 * 2e-6 / (13e-6 + 2e-6)\ \text{F} = 1.73e-6\ \text{F}$$

-
- b) Calculate the total charge stored by the combination.

Solution: $\Delta V = 8\ \text{V}$; $Q = ?$

$$Q = C_{eq} \Delta V = 1.73e-6 * 8\ \text{C} = 14e-6\ \text{C}$$

- c) Calculate the charge across the $2\ \mu\text{F}$ capacitor.

Solution: The $2\ \mu\text{F}$ capacitor and the equivalent capacitor of the capacitors in parallel are in series. Therefore the charge of the $2\ \text{F}$ capacitor should be equal to the total charge.

$$Q_3 = ?$$

$$Q = Q_{1,2} = Q = 14e-6\ \text{C}$$

d) Calculate the potential difference across the $2 \mu\text{F}$ capacitor.

Solution: $\Delta V_3 = ?$

$$\Delta V_3 = Q_3 / C_3 = 14e-6 / 2e-6 \text{ V} = 6.9 \text{ V}$$

e) Calculate the potential differences across the $8 \mu\text{F}$ and $5 \mu\text{F}$ capacitors.

Solution: The potential differences across the capacitors in parallel are equal and are also equal to the potential difference across their combination ($\Delta V_{1,2}$).

$\Delta V_1 = ?$; $\Delta V_2 = ?$

$$\Delta V_1 = \Delta V_2 = \Delta V_{1,2} = Q_{1,2} / C_{1,2} = 14e-6 / 13e-6 \text{ V} = 1.1 \text{ V}$$

SMS from your computer

...Sync'd with your Android phone & number

FREE
30 days trial!

Go to

BrowserTexting.com

and start texting from
your computer!

 **BrowserTexting**

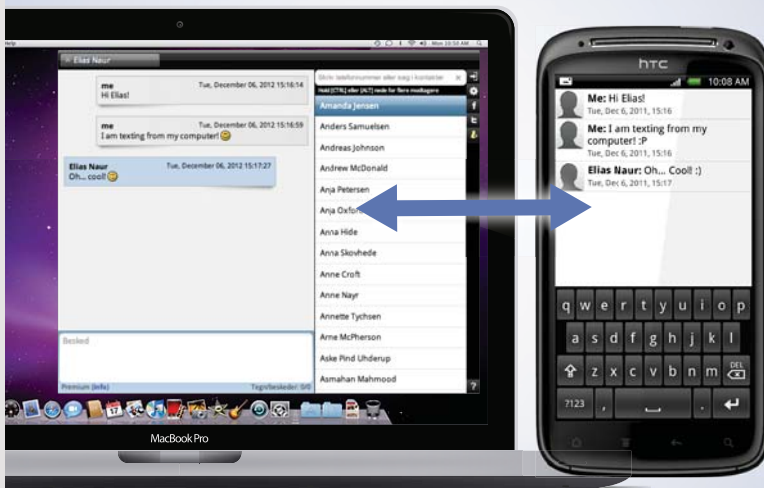

f) Calculate the charges stored by the $8 \mu\text{F}$ and $5 \mu\text{F}$ capacitors.

Solution: $Q_1 = ?$; $Q_2 = ?$

$$Q_1 = \Delta V_1 C_1 = 8e-6 * 1.1 \text{ C} = 9e-6 \text{ C}$$

$$Q_2 = Q_{1,2} - Q_1 = (14e-6 - 9e-6) \text{ C} = 5e-6 \text{ F}$$

Example: Calculate the equivalent capacitance of a series combination of a 2 F capacitor, 5 F capacitor and a parallel combination of a 6 F and 8 F capacitors.

Solution: First the equivalent capacitance ($C_{3,4}$) of the capacitors in parallel should be obtained. Then this equivalent capacitance should be combined in series with the other capacitors.

$$C_1 = 2 \text{ F}; C_2 = 5 \text{ F}; C_3 = 6 \text{ F}; C_4 = 8 \text{ F}; C_{eq} = ?$$

$$C_{3,4} = C_3 + C_4 = (6 + 8) \text{ F} = 14 \text{ F}$$

$$1/C_{eq} = 1/C_1 + 1/C_2 + 1/C_{3,4} = (1/2 + 1/5 + 1/14) \text{ 1/F} = 0.77 \text{ 1/F}$$

$$C_{eq} = 1/0.77 \text{ F} = 1.3 \text{ F}$$

2.14 PRACTICE QUIZ 2.2

Choose the best answer. Answers can be found at the back of the book.

- Which of the following is a correct statement?
 - A capacitor is a device that converts electrical energy to non-electrical energy.
 - The SI unit of measurement for capacitance is the Ohm.
 - The capacitance of a parallel plate capacitor is directly proportional to the separation between the plates.
 - The charge stored in a capacitor is inversely proportional to the potential difference across the capacitor.
 - The capacitance of a parallel plate capacitor is directly proportional to the area of the plates.

2. Which of the following is a correct statement?
- A. The total charge accumulated by capacitors in series is equal to the sum of the charges in each capacitor.
 - B. The total potential difference across capacitors connected in parallel is equal to the sum of the potential differences across each capacitor.
 - C. The total charge accumulated by capacitors in parallel is equal to the sum of the charges of the individual capacitors.
 - D. The potential differences across capacitors connected in series are equal.
 - E. The charges stored by capacitors in parallel are equal.
3. Calculate the potential difference across a $1e-5$ F capacitor with a charge of $2.6e-6$ C.
- A. 0.182 V
 - B. 0.312 V
 - C. 0.364 V
 - D. 0.234 V
 - E. 0.26 V
4. Calculate the electrical energy stored by a 0.34 F capacitor when connected to a 3 V battery.
- A. 1.224 J
 - B. 2.142 J
 - C. 1.377 J
 - D. 1.53 J
 - E. 1.989 J
5. Calculate the equivalent capacitance of a series combination of a 11 F, a 6 F and a 16 F capacitor.
- A. 3.437 F
 - B. 3.124 F
 - C. 4.374 F
 - D. 4.062 F
 - E. 3.749 F
6. Calculate the equivalent capacitance of the parallel combination of a 26 F capacitor and a series combination of a 6 F and 10 F capacitors.
- A. 35.7 F
 - B. 29.75 F
 - C. 32.725 F
 - D. 38.675 F
 - E. 17.85 F

7. A(n) 8 F and a(n) 5 F capacitors are connected in parallel and then connected to a 11 V battery. Calculate the potential difference across the 8 F capacitor.
- A. 8 V
 - B. 15 V
 - C. 12 V
 - D. 13 V
 - E. 11 V
8. A(n) 8 F and a(n) 19 F capacitors are connected in parallel and then connected to a 7 V battery. Calculate the charge accumulated by the 8 F capacitor.
- A. 56 C
 - B. 54 C
 - C. 59 C
 - D. 55 C
 - E. 60 C

YOUR WORK AT TOMTOM WILL
BE TOUCHED BY MILLIONS.
AROUND THE WORLD. EVERYDAY.

Join us now on www.TomTom.jobs

follow us on **LinkedIn**



#ACHIEVEMORE

TomTom 

9. A(n) 18 F and a(n) 21 F capacitors are connected in series and then connected to a 12 V battery. Calculate the charge accumulated by the 18 F capacitor.
- A. 104.677 C
 - B. 139.569 C
 - C. 162.831 C
 - D. 151.2 C
 - E. 116.308 C
10. A(n) 20 F and a(n) 21 F capacitors are connected in series and then connected to a 6 V battery. Calculate the potential difference across the 20 F capacitor.
- A. 3.073 V
 - B. 2.459 V
 - C. 1.844 V
 - D. 2.766 V
 - E. 2.151 V
11. The parallel combination of a(n) 8 F and a 6 F capacitors is connected in series with a(n) 28 F capacitor. And then the combination is connected to a potential difference of 45 V . Calculate the charge accumulated by the 28 F capacitor.
- A. 420 C
 - B. 546 C
 - C. 336 C
 - D. 462 C
 - E. 252 C
12. The parallel combination of a(n) 8 F and a 21 F capacitors is connected in series with a(n) 25 F capacitor. And then the combination is connected to a potential difference of 50 V . Calculate the potential difference across the 25 F capacitor.
- A. 37.593 V
 - B. 32.222 V
 - C. 26.852 V
 - D. 34.907 V
 - E. 24.167 V

3 CURRENT AND RESISTANCE

Your goals for this chapter are to learn about current, resistance, relationship between current and potential difference, and electrical power.

3.1 CURRENT

Current (I) is defined to be amount of charge (Q) that crosses a perpendicular cross-sectional area per a unit time (t).

$$I = Q/t$$

The unit of measurement for current is C/s which is defined to be the Ampere, abbreviated as A.

Example: A charge of 0.002 C crosses a cross-sectional area of a wire in 0.04 s. Calculate the current in the wire.

Solution: $Q = 0.002$ C; $t = 0.04$ s; $I = ?$

$$I = Q/t = 0.002/0.04 \text{ A} = 0.05 \text{ A}$$

3.2 RESISTANCE

A *Resistance*: is a device that converts electrical energy into some other kind of energy. For example a light bulb is a resistor that converts electrical energy to light energy; a heater is a resistor that converts electrical energy to heat energy; A loud speaker is a resistor that converts electrical energy to sound energy. The following diagram shows the circuit diagram for a resistor.



Figure 3.1

The properties of a resistor are established by a law called Ohm's law. *Ohm's law* states that the potential difference (ΔV) across a resistor is directly proportional to the current through the resistor. The constant of proportionality between the potential difference and the current (ratio between potential difference and current) is called the resistance of the resistor and is denoted by R .

$$\Delta V = IR$$

The unit of measurement for resistance is V / A which is defined to be the Ohm and abbreviated as Ω .



Brain power

By 2020, wind could provide one-tenth of our planet's electricity needs. Already today, SKF's innovative know-how is crucial to running a large proportion of the world's wind turbines.

Up to 25 % of the generating costs relate to maintenance. These can be reduced dramatically thanks to our systems for on-line condition monitoring and automatic lubrication. We help make it more economical to create cleaner, cheaper energy out of thin air.

By sharing our experience, expertise, and creativity, industries can boost performance beyond expectations. Therefore we need the best employees who can meet this challenge!

The Power of Knowledge Engineering

Plug into The Power of Knowledge Engineering.
Visit us at www.skf.com/knowledge

SKF

Example: A resistor of resistance 50Ω is connected to a potential difference of 10 V .

- a) Calculate the current through the resistor.

Solution: $R = 50 \Omega$; $\Delta V = 10 \text{ V}$; $I = ?$

$$\Delta V = IR$$

$$I = \Delta V/R = 10/50 \text{ A} = 0.2 \text{ A}$$

- b) Calculate the amount of charge that crosses the resistor in 2 s .

Solution: $t = 2 \text{ s}$; $Q = ?$

$$I = Q/t$$

$$Q = It = 0.2 * 2 \text{ A} = 0.4 \text{ A}$$

3.3 RESISTANCE OF A WIRE

The resistance (R_l) of a wire depends on its length (l) and its cross-sectional area (A). It is directly proportional to the length of the wire and inversely proportional to the cross-sectional area of the wire.

$$R_l = \rho l/A$$

ρ is a material constant called the resistivity of the material. The unit of measurement for resistivity is Ωm .

Example: A silver wire has a length of 5 m and a cross-sectional radius of 0.002 m . Silver has a resistivity of $1.59e-8 \Omega\text{m}$. It is connected to a potential difference of 0.006 V .

- a) Calculate the resistance of the wire.

Solution: $l = 5 \text{ m}$; $r = 0.002 \text{ m}$ ($A = \pi r^2$); $\rho = 1.59e-8 \Omega\text{m}$; $R_l = ?$

$$A = \pi r^2 = 3.14 * 0.002^2 \text{ m}^2 = 0.000013 \text{ m}^2$$

$$R_l = \rho l/A = 1.59e-8 * 5/0.000013 \Omega = 0.004 \Omega$$

- b) Calculate the current through the wire.

Solution: $\Delta V = 0.006$ V; $I = ?$

$$\Delta V = IR_l$$

$$I = \Delta V / R_l = 0.006 / 0.004 \text{ A} = 1.5 \text{ A}$$

3.4 RESISTIVITY AND TEMPERATURE

Resistivity of a material increases with increase of temperature, because temperature increases the kinetic energy of the particles. Change in resistivity ($\Delta\rho$) due to change of temperature is directly proportional to the change in temperature (ΔT) and to the original resistivity (ρ_o) of the material.

$$\Delta\rho = \alpha \rho_o \Delta T$$

α is a material constant called temperature coefficient of resistivity. Its unit of measurement is $1/^\circ\text{C}$. $\Delta\rho = \rho - \rho_o$ and $\Delta T = T - T_o$ where ρ is resistivity at a temperature T and ρ_o is resistivity at a temperature T_o . Replacing $\Delta\rho$ by $\rho - \rho_o$ and ΔT by $T - T_o$, the following expression for the resistivity ρ at a temperature T can be obtained.

$$\rho = \rho_o \{1 + \alpha(T - T_o)\}$$

Example: Silver has a resistivity of $1.59e-8$ Ωm at a temperature of 20 $^\circ\text{C}$. Its temperature coefficient for resistivity is $3.8e-3$ $1/^\circ\text{C}$.

- a) Calculate the resistivity of silver at a temperature of 40 $^\circ\text{C}$.

Solution: $T_o = 20$ $^\circ\text{C}$; $T = 40$ $^\circ\text{C}$; $\rho_o = 1.59e-8$ Ωm ; $\alpha = 3.8e-3$ $1/^\circ\text{C}$; $\rho = ?$

$$\rho = \rho_o \{1 + \alpha(T - T_o)\} = 1.59e-8 * \{1 + 3.8e-3 * (40 - 20)\} \Omega\text{m} = 1.7e-8 \Omega\text{m}$$

- b) Calculate the change in its resistivity when the temperature changes by 60 $^\circ\text{C}$.

Solution: $\Delta T = 60$ $^\circ\text{C}$; $\Delta\rho = ?$

$$\Delta\rho = \alpha \rho_o \Delta T = 1.59e-8 * 3.8e-3 * 60 \Omega\text{m} = 4e-9 \Omega\text{m}$$

3.5 PRACTICE QUIZ 3.1

Choose the best answer. Answers can be found at the back of the book.

1. The SI unit of measurement for resistivity of a material is
 - A. Ohm * meter
 - B. 1 / (degree Centigrade)
 - C. Ohm / meter
 - D. Volt / meter
 - E. Ohm
2. Which of the following is a correct statement?
 - A. Ohm's law states that the potential difference across a resistor is directly proportional to the current flowing through it.
 - B. The resistance of a wire is inversely proportional to the length of the wire.
 - C. Current is measured by a device called voltmeter.
 - D. The resistance of a wire is directly proportional to the cross-sectional area of the wire.
 - E. A resistor is a device that converts non-electrical energy to electrical energy.



> Apply now

REDEFINE YOUR FUTURE
**AXA GLOBAL GRADUATE
PROGRAM 2015**

redefining / standards 

agence.cdg - © Photonostop

3. A current of 7.34 A is flowing through a certain wire. How long will a charge of 0.32 C take to cross a cross-sectional area of the wire?
- A. 0.044 s
 - B. 0.026 s
 - C. 0.035 s
 - D. 0.065 s
 - E. 0.031 s
4. A current of 2.6 A flows across a resistor when connected to a(n) 17 V battery. Calculate the resistance of the resistor.
- A. $19.615\ \Omega$
 - B. $4.577\ \Omega$
 - C. $6.538\ \Omega$
 - D. $13.077\ \Omega$
 - E. $3.923\ \Omega$
5. The resistance of a silver wire of cross-sectional radius 0.00175 m is $0.032\ \Omega$. Calculate the length of the wire. (Silver has a resistivity of $1.59e-8\ \Omega\text{ m}$.)
- A. 19.363 m
 - B. 27.109 m
 - C. 25.172 m
 - D. 15.491 m
 - E. 17.427 m
6. The two ends of a nichrome wire of length 16.8 m and cross-sectional radius 0.0025 m are connected to the terminals of a 1.5 V battery. Calculate the current flowing through the wire. (Nichrome has a resistivity of $150e-8\ \Omega\text{ m}$.)
- A. 1.169 A
 - B. 1.052 A
 - C. 1.402 A
 - D. 0.818 A
 - E. 0.701 A
7. Lead has a resistivity of $22e-8\ \Omega\text{ m}$ at a temperature of $20\text{ }^\circ\text{C}$. Calculate its resistivity at a temperature of $160\text{ }^\circ\text{C}$. (Lead has resistivity temperature coefficient of $3.9e-3/^\circ\text{C}$.)
- A. $30.611e-8\ \Omega\text{ m}$
 - B. $27.21e-8\ \Omega\text{ m}$
 - C. $47.617e-8\ \Omega\text{ m}$
 - D. $34.012e-8\ \Omega\text{ m}$
 - E. $44.216e-8\ \Omega\text{ m}$

8. A certain sample of lead is at a temperature of 20°C . (Lead has a resistivity of $22e-8\ \Omega\ \text{m}$ at a temperature of 20°C .) By how much would its resistivity change, when its temperature changes by 80°C . (Lead has resistivity temperature coefficient of $3.9e-3/^\circ\text{C}$.)
- A. $6.178e-8\ \Omega\ \text{m}$
B. $6.864e-8\ \Omega\ \text{m}$
C. $5.491e-8\ \Omega\ \text{m}$
D. $4.805e-8\ \Omega\ \text{m}$
E. $4.118e-8\ \Omega\ \text{m}$

3.6 RESISTANCE AND TEMPERATURE

Change in resistance (ΔR) due to change in temperature is directly proportional to change in temperature and to the original resistance (R_0) of the resistor.

$$\Delta R = \alpha R_0 \Delta T$$

Once again, α is a material constant called the temperature coefficient of resistivity. $\Delta R = R - R_0$ and $\Delta T = T - T_0$ where R is resistance at a temperature T and R_0 is resistance at a temperature T_0 . Replacing ΔR by $R - R_0$ and ΔT by $T - T_0$, the following expression for the resistance R at a temperature T can be obtained.

$$R = R_0 \{1 + \alpha(T - T_0)\}$$

Example: A resistor has a resistance of $200\ \Omega$ at a temperature of 20°C . It is made up of a material whose temperature coefficient for resistivity is $3e-3\ 1/^\circ\text{C}$. Calculate the current through the resistor when it is connected to a potential difference of $20\ \text{V}$

- a) at a temperature of 20°C .

Solution: $R_{20} = 200\ \Omega$; $\Delta V = 20\ \text{V}$; $I_{20} = ?$

$$\Delta V = R_{20} I_{20}$$

$$I_{20} = \Delta V / R_{20} = 20 / 200\ \text{A} = 0.1\ \text{A}$$

b) at a temperature of $100\text{ }^{\circ}\text{C}$.

Solution: $T_{20} = 20\text{ }^{\circ}\text{C}$; $T_{100} = 100\text{ }^{\circ}\text{C}$; $I_{100} = \Delta V/R_{100} = ?$

$$R_{100} = R_{20} \{1 + \alpha(T_{100} - T_{20})\} = 200 * \{1 + 3e-3 * (100 - 20)\} \Omega = 248 \Omega$$

$$I_{100} = \Delta V/R_{100} = 20/248 \text{ A} = 0.08 \text{ A}$$

3.7 POWER DISSIPATION IN A RESISTOR

Power dissipation (P) in a resistor is the rate at which electrical energy (ΔPE_e) is converted to some other kind of energy.

$$P = \Delta PE_e / t$$

LIGS University based in Hawaii, USA

is currently enrolling in the
Interactive Online **BBA, MBA, MSc,**
DBA and PhD programs:

- ▶ enroll **by October 31st, 2014** and
- ▶ **save up to 11%** on the tuition!
- ▶ pay in 10 installments / 2 years
- ▶ Interactive **Online education**
- ▶ visit www.ligsuniversity.com to
find out more!

Note: LIGS University is not accredited by any
nationally recognized accrediting agency listed
by the US Secretary of Education.
More info [here](#).



The unit of measurement for power is J/s which is defined to be the Watt, abbreviated as W. The change in potential energy of a charge Q that crosses a resistor of potential difference ΔV is given as $\Delta PE_e = Q\Delta V$. Thus the power dissipated in a resistor is given by $P = Q\Delta V/t$. But $Q/t = I$. Therefore power dissipated in a resistor is equal to the product of the potential difference across the resistor and the current through the resistor.

$$P = \Delta VI$$

An expression in terms of current and resistance can be obtained by replacing ΔV by IR .

$$P = I^2R$$

An expression in terms of potential difference and resistance can be obtained by replacing I by $\Delta V/R$.

$$P = \Delta V^2/R$$

Kilo Watt hour (Kwh) is a unit of energy defined to be equal to the energy dissipated in one hour by a resistor whose power is 1 kW. Thus, 1 KWh is equal to $1000 * 3600$ J.

$$1 \text{ kWh} = 3.6e6 \text{ J}$$

Example: A 500Ω is connected to a potential difference of 110 V .

- a) Calculate the power dissipated in the resistor.

Solution: $R = 500 \Omega$; $\Delta V = 110 \text{ V}$; $P = ?$

$$P = \Delta V^2/R = 110^2/500 \text{ W} = 24 \text{ W}$$

-
- b) How much energy is dissipated in 2 hours?

Solution: $t = 2 * 3600 \text{ s} = 7200 \text{ s}$; $\Delta PE_e = ?$

$$\Delta PE_e = Pt = 24 * 7200 \text{ J} = 172800 \text{ J}$$

Example: There is a current of 2 A in a 60 W lamp.

- a) Calculate the resistance of the resistor.

Solution: $P = 60 \text{ W}$; $I = 2 \text{ A}$; $R = ?$

$$P = I^2 R$$

$$R = P/I^2 = 60/2^2 \Omega = 15 \Omega$$

- b) Calculate the potential difference across the resistor.

Solution: $\Delta V = ?$

$$\Delta V = IR = 2 * 15 \text{ V} = 30 \text{ V}$$

Example: The price of electrical energy is \$0.15 / kWh. How much does it cost to run a 400 W device for one month at 3 hours per day?

Solution: $P = 400 \text{ W}$; $t = 3 * 30 * 3600 \text{ s} = 324000 \text{ s}$; $price = \$0.15$ per kWh; $cost = (price) \Delta PE_e = ?$

$$\Delta PE_e = Pt = 400 * 324000 \text{ J} = 129600000 \text{ J} = 129600000 \text{ J} * (\text{kWh} / 3.6e6 \text{ J}) = 36 \text{ kWh}$$

$$cost = (price) \Delta PE_e = (\$0.15 / \text{kWh}) * (36 \text{ kWh}) = \$5.4$$

3.8 PRACTICE QUIZ 3.2

Choose the best answer. Answers can be found at the back of the book.

1. Which of the following is a correct statement?
 - A. Change in the resistivity of a material is inversely proportional to the change in its temperature.
 - B. Change in the resistivity of a material is inversely proportional to its initial resistivity.
 - C. Change in the resistivity of a material is directly proportional to the change in its temperature.
 - D. Change in the resistivity of a material is directly proportional to its temperature.
 - E. Kilo Watt Hour (kWh) is a unit of measurement of power.
2. Covert 1.3 J to kWh.
 - A. $0.506e-6$ kWh
 - B. $0.253e-6$ kWh
 - C. $0.397e-6$ kWh
 - D. $0.361e-6$ kWh
 - E. $0.289e-6$ kWh

TURN TO THE EXPERTS FOR **SUBSCRIPTION** CONSULTANCY

Subscribe is one of the leading companies in Europe when it comes to innovation and business development within subscription businesses.

We innovate new subscription business models or improve existing ones. We do business reviews of existing subscription businesses and we develop acquisition and retention strategies.

Learn more at [linkedin.com/company/subscribe](https://www.linkedin.com/company/subscribe) or contact Managing Director Morten Suhr Hansen at mha@subscribe.dk

SUBSCR✓**IBE** - to the future

3. 5A resistor made of silver has a resistance of $100\ \Omega$ at a temperature of $20\ ^\circ\text{C}$. To what temperature should it be heated if its resistance is to increase to $107\ \Omega$. (Silver has a resistivity temperature coefficient of $3.8e-3/^\circ\text{C}$.)
- A. $53.789\ ^\circ\text{C}$
 - B. $42.263\ ^\circ\text{C}$
 - C. $49.947\ ^\circ\text{C}$
 - D. $38.421\ ^\circ\text{C}$
 - E. $46.105\ ^\circ\text{C}$
4. A resistor made of silver has a resistance of $90\ \Omega$ at a temperature of $20\ ^\circ\text{C}$. By how much should its temperature change if its resistance is to increase by 8%. (Silver has a resistivity temperature coefficient of $3.8e-3/^\circ\text{C}$.)
- A. $27.368\ ^\circ\text{C}$
 - B. $23.158\ ^\circ\text{C}$
 - C. $29.474\ ^\circ\text{C}$
 - D. $25.263\ ^\circ\text{C}$
 - E. $21.053\ ^\circ\text{C}$
5. A current of $4.7\ \text{A}$ flows through a lead wire of length $13.9\ \text{m}$ and cross-sectional radius $0.00325\ \text{m}$ at a temperature of $160\ ^\circ\text{C}$ when its ends are connected to the terminals of a battery. Calculate the potential difference between the ends of the wire. (Lead has a resistivity of $22e-8\ \Omega\ \text{m}$ at $20\ ^\circ\text{C}$ and a resistivity temperature coefficient of $3.9e-3/^\circ\text{C}$.)
- A. $0.804\ \text{V}$
 - B. $0.469\ \text{V}$
 - C. $0.67\ \text{V}$
 - D. $0.402\ \text{V}$
 - E. $0.737\ \text{V}$
6. A resistor made of lead has a resistance of $10\ \Omega$ at a temperature of $20\ ^\circ\text{C}$. The resistor is heated to a temperature of $160\ ^\circ\text{C}$ and then connected to a $20\ \text{V}$ battery. Calculate the current flowing through the resistor. (Lead has resistivity temperature coefficient of $3.9e-3/^\circ\text{C}$.)
- A. $0.906\ \text{A}$
 - B. $1.423\ \text{A}$
 - C. $1.552\ \text{A}$
 - D. $1.294\ \text{A}$
 - E. $1.811\ \text{A}$

7. When a certain resistor is connected to a 10.6 V battery, a current of 1.5 A flows through it. Calculate the rate at which energy is dissipated in the resistor.
- A. 22.26 W
 - B. 15.9 W
 - C. 11.13 W
 - D. 19.08 W
 - E. 17.49 W
8. The rate of dissipation of energy in a resistor connected to a 40 V battery is 30.6 W . Calculate the current through the resistor.
- A. 0.459 A
 - B. 0.842 A
 - C. 0.995 A
 - D. 0.612 A
 - E. 0.765 A
9. When a certain resistor is connected to a 14.7 V battery, a current of 1.5 A flows through it. Calculate the amount of energy dissipated in the resistor in 3 hours.
- A. $14.288e4\text{ J}$
 - B. $21.433e4\text{ J}$
 - C. $19.051e4\text{ J}$
 - D. $16.67e4\text{ J}$
 - E. $23.814e4\text{ J}$
10. A $18.1\ \Omega$ resistor is connected to a 20 V battery. If electricity costs $\text{\$}13$ per kilo Watt hour, how much would it cost to run this resistor for 900 hours.
- A. $\text{\$}361.989$
 - B. $\text{\$}258.564$
 - C. $\text{\$}206.851$
 - D. $\text{\$}336.133$
 - E. $\text{\$}284.42$

4 DIRECT CURRENT CIRCUITS

Your goals for this chapter are to learn about electromotive force, combination of resistors and Kirchoff's rules.

There are two types of circuits. They are direct current (dc) circuits and alternating current (ac) circuits. A *dc circuit* is a circuit where the current or the voltage are constant in time. An *ac circuit* is a circuit where the voltage or the current vary with time typically like a sine or a cosine.

4.1 ELECTROMOTIVE FORCE OF A SOURCE

A *source* is a device that converts non electrical energy to electrical energy. Examples are a battery and a hydroelectric generator. A battery converts chemical energy to electrical energy. A hydroelectric generator converts mechanical energy to electrical energy. The following diagram shows the circuit symbol for a dc source. The longer line represents the positive terminal and the shorter line represents the negative terminal.



"I studied English for 16 years but...
...I finally learned to speak it in just six lessons"
Jane, Chinese architect

ENGLISH OUT THERE

Click to hear me talking before and after my unique course download

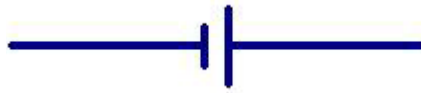
**Figure 4.1**

The amount of work done per a unit charge by a source in transporting a charge from one of its terminals to the other is called the *electromotive force* (abbreviated as emf) of the source.

$$E = W_s / q$$

Where E is the emf of a source and W_s is work done by a source in transporting a charge q from one of its terminals to the other. The unit of measurement for emf of a source is the Volt. Any source has its own internal resistance. The potential difference between the terminals of a source is less than the emf of the source, because some of its emf is dropped across its own internal resistance. If a current I is flowing across a source, the potential difference across its own resistance r is equal to Ir . Hence the potential difference (ΔV_s) across the terminal of a source is equal to the difference between its emf and the potential drop across its own internal resistance.

$$\Delta V_s = E - Ir$$

If a source is connected to an external resistance R , the potential difference across the external resistance (IR) is equal to the potential difference across the terminals of the source; that is $\Delta V_s = E - Ir = IR$. And solving for the current

$$I = E / (R + r)$$

Example: A battery of emf 20 V and internal resistance 2 Ω is connected to an external resistance of 48 Ω

- a) Calculate the current in the circuit.

Solution: $E = 20$ V; $r = 2$ Ω ; $R = 48$ Ω ; $I = ?$

$$I = E / (R + r) = 20 / (48 + 2) \text{ A} = 0.4 \text{ A}$$

b) Calculate the potential difference across the terminal of the battery.

$$\text{Solution: } \Delta V = ? \quad \Delta V_s = E - Ir = (20 - 0.4 * 2) \text{ V} = 19.2 \text{ V}$$

c) Calculate the potential drop across the external resistance.

$$\text{Solution: } \Delta V_R = ?$$

$$\Delta V_R = IR = 0.4 * 48 = 19.2 \text{ V}$$

Or

$$\Delta V_R = \Delta V_s = 19.2 \text{ V}$$

4.2 POWER OF A SOURCE

The *power of a source* (P_s) is the rate at which the source is converting non-electrical energy to electrical energy. In other words, it is the rate of doing work by the source in transporting charges from one of the terminals to the other; that is $P_s = W_s/t$. and since $W_s = Eq$, $P_s = E(q/t)$. But $q/t = I$. Therefore the power of a source is equal to the product of its emf and the current across it.

$$P_s = EI$$

The power delivered to the external resistance (P_R) is less than the power of the source because some of the power is dissipated in its own internal resistance. Power dissipated in its internal resistance is equal to I^2r . The power delivered to the external resistance is also equal to the power dissipated in the external resistance (I^2R).

$$P_R = EI - I^2r = I^2R$$

Example: A battery of emf 6 V and internal resistance $5\ \Omega$ is connected to resistance of $15\ \Omega$.

a) Calculate the current in the circuit.

Solution: $E = 6\text{ V}$; $r = 5\ \Omega$; $R = 15\ \Omega$; $I = ?$

$$I = E / (R + r) = 6 / (15 + 5)\ \Omega = 0.3\ \text{A}$$

b) Calculate the power of the source.

Solution: $P_s = ?$

$$P_s = EI = 6 * 0.3\ \text{W} = 1.8\ \text{W}$$

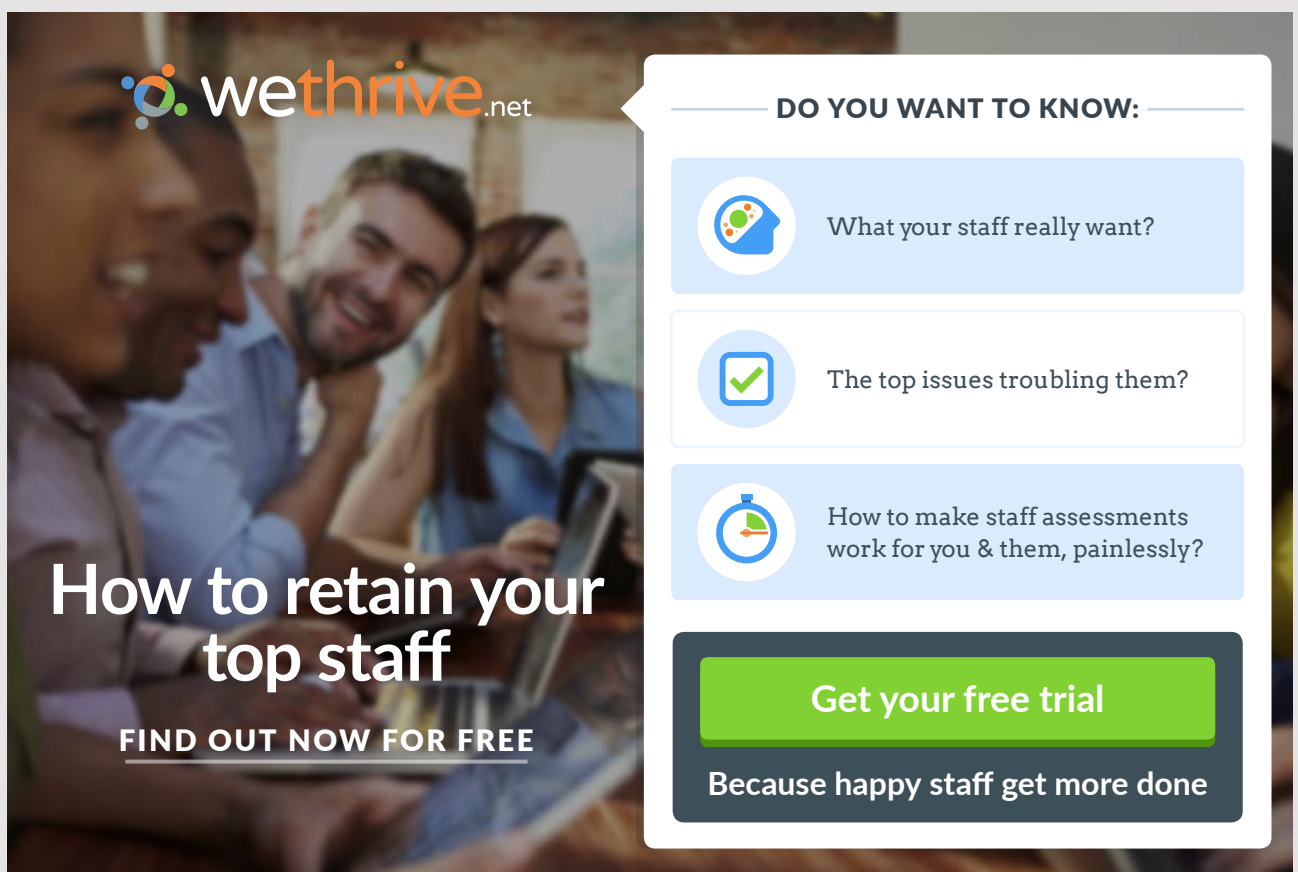

wethrive.net

How to retain your top staff

FIND OUT NOW FOR FREE

DO YOU WANT TO KNOW:

- What your staff really want?
- The top issues troubling them?
- How to make staff assessments work for you & them, painlessly?

Get your free trial

Because happy staff get more done

c) Calculate the power delivered to the external circuit.

Solution: $P_R = ?$

$$P_R = EI - I^2r = (6 * 0.05 - 0.05^2 * 5) \text{ W} = 0.2875 \text{ W}$$

d) Calculate the power dissipated in the external resistance.

Solution: The power dissipated in the external resistance is equal to the power delivered by the source to the external resistance which is 0.2875 W . Or

$$P_R = I^2R = 0.05^2 * 115 \text{ W} = 0.2875 \text{ W}$$

4.3 COMBINATION OF RESISTORS

An *equivalent resistance* (R_{eq}) of a combination of resistors is defined to be the single resistor that can replace the combination without changing the current and potential difference across the combination. It is equal to the ratio between the total potential difference across the combination (ΔV) and the total current (I) across the combination.

$$R_{eq} = \Delta V / I$$

4.3.1 SERIES COMBINATION OF RESISTORS

Series combination of resistors is combination where the resistors are connected in a single line. The following diagram shows series combination of three resistors.



Figure 4.2

Let's consider resistors R_1, R_2, R_3, \dots connected in series. Since they are connected in a single line, the currents through all of them are the same and are equal to the total current across the combination.

$$I = I_1 = I_2 = I_3 = \dots$$

Where I_1, I_2, I_3, \dots are currents across resistors R_1, R_2, R_3, \dots respectively. I is the total current across the combination. The total potential difference across the combination is equal to the sum of the potential differences across the individual resistors.

$$\Delta V = \Delta V_1 + \Delta V_2 + \Delta V_3 + \dots$$

$\Delta V_1, \Delta V_2, \Delta V_3, \dots$ are potential differences across resistors R_1, R_2, R_3, \dots respectively. ΔV is the total potential difference across the combination. Replacing each potential difference in this equation by the product of the corresponding current and resistance and noting that all the currents are equal, the following expression for the equivalent resistance of a series combination can be obtained.

$$R_{eq} = R_1 + R_2 + R_3 + \dots$$

Example: A 5Ω and a 15Ω resistors are connected in series and the connected to a potential difference of 40 V .

- a) Calculate their equivalent resistance.

Solution: $R_1 = 5 \Omega; R_2 = 15 \Omega; R_{eq} = ?$

$$R_{eq} = R_1 + R_2 = (5 + 15) \Omega = 20 \Omega$$

- b) Calculate the currents across each resistor.

Solution: $\Delta V = 40 \text{ V}; I_1 = ?; I_2 = ?$

$$I_1 = I_2 = I = \Delta V / R_{eq} = 40 / 20 \text{ A} = 2 \text{ A}$$

- c) Calculate the potential differences across each resistor.

Solution: $\Delta V_1 = ?; \Delta V_2 = ?$

$$\Delta V_1 = I_1 R_1 = 2 * 5 \text{ V} = 10 \text{ V}$$

$$\Delta V_2 = I_2 R_2 = 2 * 15 \text{ V} = 30 \text{ V}$$

4.3.1 PARALLEL COMBINATION OF RESISTORS

Parallel Combination of Resistors is branched combination where the resistors share the same terminals on both sides. The following diagram shows parallel combination of three resistors.

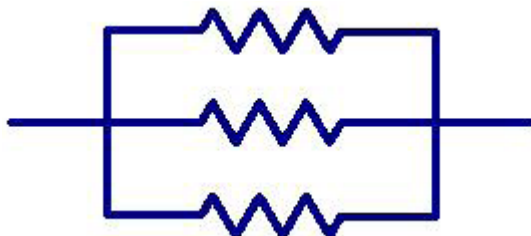

Figure 4.3

The potential differences across resistors combined in parallel are equal and are equal to the total potential difference across the combination because the resistors share the same terminal on both sides.

$$\Delta V = \Delta V_1 + \Delta V_2 + \Delta V_3 + \dots$$

gaiTEYE[®]
Challenge the way we run

**EXPERIENCE THE POWER OF
FULL ENGAGEMENT...**

.....

**RUN FASTER.
RUN LONGER..
RUN EASIER...**

**READ MORE & PRE-ORDER TODAY
WWW.GAITEYE.COM**

$\Delta V_1, \Delta V_2, \Delta V_3, \dots$ are potential differences across resistors R_1, R_2, R_3, \dots respectively. ΔV is the total potential difference across the combination. The total current across the combination is equal to the sum of the currents across the individual resistors.

$$I = I_1 + I_2 + I_3 + \dots$$

I_1, I_2, I_3, \dots are currents across resistors R_1, R_2, R_3, \dots respectively. I is the total current across the combination. Replacing each current in this equation by the corresponding ratio between the corresponding potential difference and resistance and noting that all the potential differences are equal, the following expression for the equivalent resistance of resistors combined in parallel can be obtained.

$$1/R_{eq} = 1/R_1 + 1/R_2 + 1/R_3 + \dots$$

If there are two resistors only, this expression can be simplified by direct addition: $1/R_{eq} = (R_1 + R_2)/(R_1 R_2)$. And an expression for the equivalent resistance of two resistors in parallel is obtained by inverting this equation.

$$R_{eq} = R_1 R_2 / (R_1 + R_2)$$

Example: A 6Ω and an 8Ω resistors are connected in parallel and then connected to a potential difference of 16 V .

- a) Calculate their equivalent resistance.

Solution: $R_1 = 6\Omega; R_2 = 8 \Omega; R_{eq} = ?$

$$R_{eq} = R_1 R_2 / (R_1 + R_2) = 6 * 8 / (6 + 8) \Omega = 3.4 \Omega$$

-
- b) Calculate the potential difference across each resistor.

Solution: $\Delta V = 16 \text{ V}; \Delta V_1 = ?; \Delta V_2 = ?$

$$\Delta V_1 = \Delta V_2 = \Delta V = 16 \text{ V}$$

c) Calculate the current across each resistor.

Solution: $I_1 = ?$; $I_2 = ?$

$$I_1 = \Delta V_1 / R_1 = 16 / 6 \text{ A} = 2.7 \text{ A}$$

$$I_2 = \Delta V_2 / R_1 = 16 / 8 \text{ A} = 2 \text{ A}$$

4.3.2 PARALLEL-SERIES COMBINATION

When a combination involves a number of series and parallel combinations, the problem can be dealt with by replacing each parallel or series combination by its equivalent resistance and repeating the process as necessary.

Example Calculate the equivalent resistance of a 10Ω , a 20Ω , a 30Ω and a 40Ω resistors

a) When they are connected in series.

Solution: $R_1 = 10 \Omega$; $R_2 = 20 \Omega$; $R_3 = 30 \Omega$; $R_4 = 40 \Omega$; $R_{eq} = ?$

$$R_{eq} = R_1 + R_2 + R_3 + R_4 = (10 + 20 + 30 + 40) \Omega = 100 \Omega$$

b) When they are connected in parallel.

Solution: $R_{eq} = ?$

$$1/R_{eq} = 1/R_1 + 1/R_2 + 1/R_3 + 1/R_4 = (1/10 + 1/20 + 1/30 + 1/40) 1/\Omega = 0.21 1/\Omega$$

$$R_{eq} = 1 / 0.21 \Omega = 4.8 \Omega$$

- c) when the parallel combination of the 10 , 20 and 30Ω is connected in series with the 40Ω resistor.

Solution: First the equivalent resistance of the resistors in parallel ($R_{1,2,3}$) should be obtained. Then this equivalent resistance should be combined in series with the 40Ω resistor.

$$R_{eq} = ?$$

$$1/R_{1,2,3} = 1/R_1 + 1/R_2 + 1/R_3 = (1/10 + 1/20 + 1/30) 1/\Omega = 0.18 1/\Omega$$

$$R_{1,2,3} = 1/0.18 \Omega = 5.6 \Omega$$

$$R_{eq} = R_{1,2,3} + R_4 = (5.6 + 4) \Omega = 9.6 \Omega$$

This e-book
is made with
SetaPDF

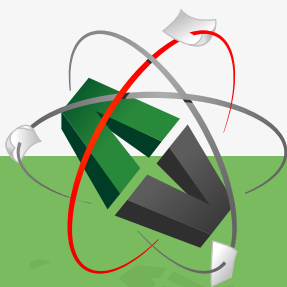

PDF components for PHP developers

www.setasign.com



- d) when a parallel combination of the 10 and $20\ \Omega$ resistors is connected in series with a parallel combination of the 30 and $40\ \Omega$ resistors.

Solution: First the equivalent resistances of the parallel combinations ($R_{1,2}$ and $R_{3,4}$). Then these equivalent resistances should be combined in series.

$$R_{eq} = ?$$

$$R_{1,2} = R_1 R_2 / (R_1 + R_2) = 10 * 20 / (10 + 20)\ \Omega = 6.7\ \Omega$$

$$R_{3,4} = R_3 R_4 / (R_3 + R_4) = 30 * 40 / (30 + 40)\ \Omega = 7.7\ \Omega$$

$$R_{eq} = R_{1,2} + R_{3,4} = (6.7 + 7.7)\ \Omega = 14.4\ \Omega$$

Example: A parallel combination of a 5 and 15 ohm resistors is connected in series with a 20 ohm resistor. Then the combination is connected to a potential difference of 30 V.

- a) Calculate the equivalent resistance of the combination.

Solution: First the equivalent resistance of the parallel combination ($R_{1,2}$) should be obtained; and then this resistance should be combined in series with the other resistor.

$$R_1 = 5\ \Omega; R_2 = 15\ \Omega; R_3 = 20\ \Omega; R_{eq} = ?$$

$$R_{1,2} = R_1 R_2 / (R_1 + R_2) = 5 * 15 / (5 + 15)\ \Omega = 3.75\ \Omega$$

$$R_{eq} = R_{1,2} + R_3 = (3.75 + 20)\ \Omega = 23.75\ \Omega$$

- b) Calculate the current and potential difference across the $20\ \Omega$ resistor.

Solution: Since the 20 ohm resistor is in series with $R_{1,2}$, the current across the 20 ohm resistor should be equal to the total current.

$$\Delta V = 30\ \text{V}; I_3 = ?; \Delta V_3 = ?$$

$$I_3 = I_{1,2} = I = \Delta V / R_{eq} = 30 / 23.75\ \text{A} = 1.3\ \text{A}$$

$$\Delta V_3 = I_3 R_3 = 1.3 * 20\ \text{V} = 26\ \text{V}$$

- c) Calculate the currents and potential differences across the 5 and 15 ohm resistors.

Solution: Since they are connected in parallel their potential differences are to the potential difference across $R_{1,2}$. And since $R_{1,2}$ and R_3 are in series, $\Delta V_3 + \Delta V_{1,2} = \Delta V$.

$$\Delta V_1 = ?; \Delta V_2 = ?; I_1 = ?; I_2 = ?$$

$$\Delta V_1 = \Delta V_2 = \Delta V_{1,2} = \Delta V - \Delta V_3 = (30 - 26) \text{ V} = 4 \text{ V}$$

$$I_1 = \Delta V_1 / R_1 = 4 / 5 \text{ A} = 0.8 \text{ A}$$

$$I_2 = \Delta V_2 / R_2 = 4 / 15 \text{ A} = 0.27 \text{ A}$$

4.4 PRACTICE QUIZ 4.1

Choose the best answer. Answers can be found at the back of the book.

- Which of the following is a correct statement?
 - Emf of a source is defined to be the rate of conversion of electrical energy to non-electrical energy of the source.
 - A source is a device that converts electrical energy to non-electrical energy.
 - The rate of dissipation of electrical energy in a resistor connected to a battery is always equal to the rate of production of electrical energy in the battery.
 - A capacitor is an example of a source.
 - The potential difference across the terminals of a battery is equal to the difference between the emf of the battery and the potential drop across the internal resistance of the battery.
- Which of the following statements is correct?
 - The potential differences across resistors connected in series are equal.
 - The total current across resistors connected in series is equal to the sum of the currents across the resistors.
 - The currents across resistors connected in parallel are equal.
 - The total potential difference across resistors connected in parallel is equal to the sum of the potential differences across the resistors.
 - The currents across resistors connected in series are equal.

3. A battery of emf 20 V and internal resistance 6 Ohm is connected to an external resistance of 60 Ohm . Calculate the current in the circuit.
- A. 0.303 A
 - B. 0.273 A
 - C. 0.182 A
 - D. 0.364 A
 - E. 0.394 A
4. When a battery of internal resistance 3 Ohm is connected to an external resistance, a current of 0.85 A flows in the circuit. If the potential difference between the terminals of the battery is measured to be 17.8 V , calculate the emf of the battery.
- A. 12.21 V
 - B. 20.35 V
 - C. 18.315 V
 - D. 24.42 V
 - E. 14.245 V



Discover the truth at www.deloitte.ca/careers

Deloitte.

© Deloitte & Touche LLP and affiliated entities.

5. A battery of emf 18 V and internal resistance 7 Ohm is connected to an external resistance of 55 Ohm . Calculate rate of dissipation of electrical energy in the external resistor.
- A. 6.49 W
 - B. 4.636 W
 - C. 6.027 W
 - D. 4.172 W
 - E. 5.563 W
6. When a battery of internal resistance 4 Ohm is connected to an external resistance of 19 Ohm , a current of 0.95 A flows in the circuit. Calculate the rate of production of electrical energy in the battery.
- A. 26.985 W
 - B. 22.833 W
 - C. 29.06 W
 - D. 20.758 W
 - E. 16.606 W
7. Calculate the equivalent resistance of a parallel combination of a(n) 5 Ohm , a(n) 3 Ohm and a(n) 16 Ohm resistor.
- A. 2.014 Ohm
 - B. 1.007 Ohm
 - C. 2.182 Ohm
 - D. 1.678 Ohm
 - E. 1.51 Ohm
8. Calculate the equivalent resistance of the series combination of a(n) 5 Ohm resistor and a parallel combination of a(n) 6 Ohm and a(n) 7 Ohm resistors.
- A. 8.231 Ohm
 - B. 4.938 Ohm
 - C. 9.054 Ohm
 - D. 10.7 Ohm
 - E. 9.877 Ohm

9. A(n) $20\ \Omega$ and a(n) $11\ \Omega$ resistors are connected in parallel and then connected to a $16\ \text{V}$ battery. Calculate the potential difference across the $20\ \Omega$ resistor.
- A. $12\ \text{V}$
 - B. $19\ \text{V}$
 - C. $17\ \text{V}$
 - D. $16\ \text{V}$
 - E. $14\ \text{V}$
10. A(n) $20\ \Omega$ and a(n) $17\ \Omega$ resistors are connected in parallel and then connected to a(n) $7\ \text{V}$ battery. Calculate the current through the $20\ \Omega$ resistor.
- A. $0.35\ \text{A}$
 - B. $0.315\ \text{A}$
 - C. $0.245\ \text{A}$
 - D. $0.28\ \text{A}$
 - E. $0.49\ \text{A}$
11. A(n) $18\ \Omega$ and a(n) $17\ \Omega$ resistors are connected in series and then connected to a(n) $14\ \text{V}$ battery. Calculate the current through the $18\ \Omega$ resistor.
- A. $0.28\ \text{A}$
 - B. $0.56\ \text{A}$
 - C. $0.44\ \text{A}$
 - D. $0.48\ \text{A}$
 - E. $0.4\ \text{A}$
12. A(n) $18\ \Omega$ and a(n) $21\ \Omega$ resistors are connected in series and then connected to a $15\ \text{V}$ battery. Calculate the potential difference across the $18\ \Omega$ resistor.
- A. $5.538\ \text{V}$
 - B. $9.692\ \text{V}$
 - C. $6.923\ \text{V}$
 - D. $9\ \text{V}$
 - E. $7.615\ \text{V}$

13. The parallel combination of a(n) $2\ \Omega$ and a $15\ \Omega$ resistors is connected in series with a(n) $13\ \Omega$ resistor. And then the combination is connected to a potential difference of $45\ \text{V}$. Calculate the current through the $13\ \Omega$ resistor.
- A. $4.267\ \text{A}$
 - B. $3.048\ \text{A}$
 - C. $3.962\ \text{A}$
 - D. $2.743\ \text{A}$
 - E. $2.438\ \text{A}$
14. The parallel combination of a(n) $23\ \Omega$ and a $27\ \Omega$ resistors is connected in series with a(n) $28\ \Omega$ resistor. And then the combination is connected to a potential difference of $45\ \text{V}$. Calculate the potential difference across the $28\ \Omega$ resistor.
- A. $28.055\ \text{V}$
 - B. $21.821\ \text{V}$
 - C. $37.407\ \text{V}$
 - D. $18.704\ \text{V}$
 - E. $31.173\ \text{V}$

© 2013 Accenture. All rights reserved.

be > your degree

Bring your talent and passion to a global organization at the forefront of business, technology and innovation. Discover how great you can be.

Visit accenture.com/bookboon

Be greater than.
consulting | technology | outsourcing

accenture
High performance. Delivered.

4.5 KIRCHOFF'S RULES

Kirchoff's rules are rules used to solve complex circuits. There are two of them. They are known as the junction rule and the loop rule.

Kirchoff's junction rule states that the sum of all the currents in a junction is zero.

$$\sum I = I_1 \pm I_2 \pm I_3 \dots = 0$$

A *junction* is a point in a circuit where two or more wires meet. Currents headed towards the junction are taken to be positive whereas currents going away from the junction are taken to be negative.

Kirchoff's loop rule states that the sum of all potential differences in a loop is zero.

$$\sum \Delta V = \Delta V_1 + \Delta V_2 + \Delta V_3 + \dots = 0$$

In going around a loop, to apply the loop rule a transversing direction (clockwise or counter clockwise) should be chosen. The potential difference across the terminals of a battery is taken to be positive if the battery is transversed from its negative to its positive terminal and negative if transversed from its positive terminal to its negative terminal. The potential difference across the terminals of a resistor is taken to be negative if the resistor is transversed in the direction of the current and positive if transversed opposite to the direction of the current.

4.5.1 APPLYING KIRCHOFF'S RULES

In applying Kirchoff's rules, the following procedures may be followed.

1. For each wire in the circuit, assign a variable to the current and choose a direction for the current arbitrarily. If after solving the problem a current turns out to be positive, the actual direction of the current is the same as the chosen direction; and if the current turns out to be negative, the actual direction of the current is opposite to the chosen direction.
2. Assign transversing direction to each simple loop in the circuit. A *simple loop* is a non-intersecting loop or a loop that is not divided into more loops. This is the direction to be followed while applying Kirchoff's loop rule.

3. If there are n junctions in a circuit, apply the Kirchoff's junction rule only to $n - 1$ of them, because the n^{th} junction will not result in an independent equation. Current variables should be treated as positives. Negatives should be introduced outside the variable. For example if a current I is going away from a junction, in applying the junction rule, it should appear as $-I$.
 4. Apply the loop rule to all the simple loops of the circuit. A starting point should be chosen for each simple loop and the loop should be transversed in the direction of the chosen transversing direction to add all the potential differences in the simple loop. Variables for unknown emfs should be treated as positives. Negatives should be introduced outside the variable. For example if the unknown emf is represented by E and the battery is transversed from its positive to its negative terminal, in applying the loop rule, it should appear as $-E$.
 5. Solve the resulting system of linear equations.
-

Example: Consider the circuit shown below. Resistors A and C have resistances of 20 and 60 ohm respectively. Batteries B and D have emfs of 8 and 4 V respectively. Determine the value and the direction of the current in the circuit.

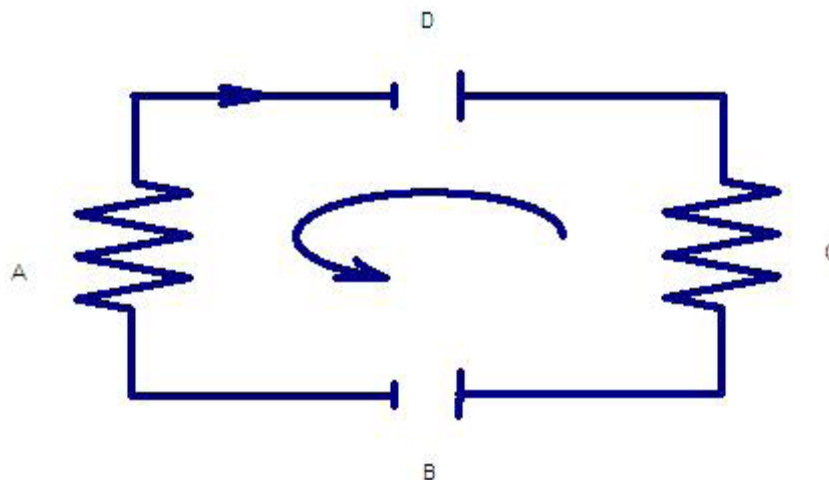

Figure 4.4

Solution: The circuit has only one simple loop and one wire. Thus the circuit has only one current. First an arbitrary direction for the current and a transversing direction should be chosen. These arbitrary directions are already indicated in the circuit above. This circuit does not have a junction and thus no need to apply the junction rule. Only the loop rule need to be applied. The potential differences across both resistors should be taken to be positive because they are being transverse opposite to the direction of the current. The potential difference across the terminals of battery B should be taken to be positive because the battery is being transversed from its negative to its positive terminal. The potential difference across the terminals of battery D should be taken to be negative because the battery is being transversed from its positive to its negative terminal. Let the starting point be the lower right corner of the circuit.

$$R_A = 20 \Omega; R_C = 60 \Omega; E_B = 8 \text{ V}; E_D = 4 \text{ V}; I = ?$$

$$\sum \Delta V = \Delta V_1 + \Delta V_2 + \Delta V_3 + \dots = 0$$

$$IR_C - E_D + IR_A + E_B = 0$$

$$I(60 \Omega) - 4 \text{ V} + I(20 \Omega) + 8 \text{ V} = 0$$

The Wake

the only emission we want to leave behind

Low-speed Engines Medium-speed Engines Turbochargers Propellers Propulsion Packages PrimeServ

The design of eco-friendly marine power and propulsion solutions is crucial for MAN Diesel & Turbo. Power competencies are offered with the world's largest engine programme – having outputs spanning from 450 to 87,220 kW per engine. Get up front! Find out more at www.mandieselturbo.com

Engineering the Future – since 1758.

MAN Diesel & Turbo



$$I(80 \Omega) = -4 \text{ V}$$

$$I = -4/80 \text{ A} = -0.05 \text{ A}$$

Since the current turned out to be negative the actual direction should be opposite to the assigned direction (clockwise). The actual direction of the current is counter clockwise.

Example: Consider the circuit shown below. Resistors A, C and D have resistances of 10, 20 and 30 ohm respectively. Batteries B, E and F have emfs of 6, 12 and 20 V. Calculate all the currents in the circuit.

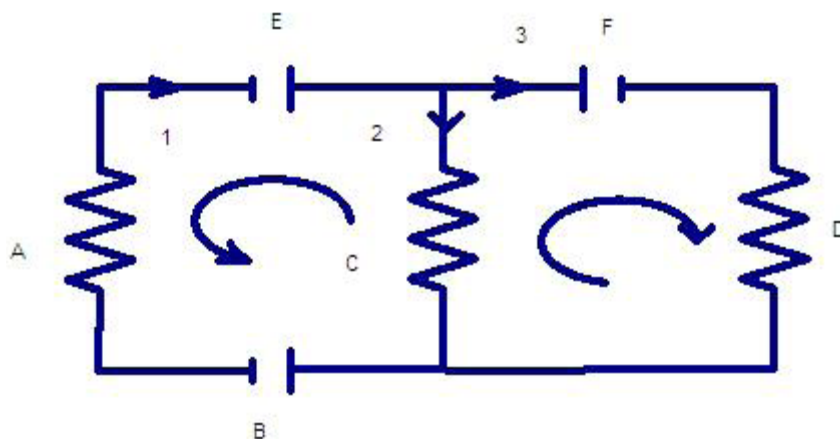

Figure 4.5

Solution: The circuit has two simple loops (loops ABCEA and CDFC) and two junctions. Thus the loop rule should be applied to both simple loops and the junction rule should be applied to one of the junctions. The circuit has three different wires marked as 1, 2 and 3. Thus there are three different currents (I_1 , I_2 and I_3) in the circuit. The arbitrary directions of the currents and the arbitrary transversing directions of the simple loops are already indicated in the circuit.

$$R_A = 10 \Omega; R_C = 20 \Omega; R_D = 30 \Omega; E_B = 6 \text{ V}; E_E = 12 \text{ V}; E_F = 20 \text{ V}; I_1 = ?; I_2 = ?; I = ?$$

The junction rule should be applied to one of the junctions say the upper junction. I_1 should be taken to be positive because it is directed towards the junction. I_2 and I_3 should be multiplied by $-I$ because they are directed away from the junction.

$$I_1 - I_2 - I_3 = 0$$

$$I_3 = I_1 - I_2 \dots \dots (1)$$

In the equations to follow I_3 will be replaced by $I_1 - I_2$ to get two equations in two variables.

Next the loop rule should be applied to one of the simple loops, say the simple loop on the left (loop ABCEA). The potential differences across resistors A and C should be taken to be positive because the resistors are being transversed opposite to the directions of the assigned currents. The potential difference across the terminals of battery B should be taken to be positive because it is being transversed from its negative to its positive terminal. The potential difference across the terminals of battery E should be taken to be negative because it is being transversed from its positive to its negative terminal. Starting at the left lower corner of the circuit

$$E_B + I_2 R_C - E_E + I_1 R_A = 0$$

$$6 \text{ V} + I_2 (20 \Omega) - 12 \text{ V} + I_1 (10 \Omega) = 0$$

$$10I_1 + 20I_2 = 6 \text{ A}$$

$$I_2 = (6 \text{ A} - 10I_1)/20 = 0.3 \text{ A} - 0.5I_1 \dots (2)$$

Next the loop rule should be applied to the second simple loop (loop CDFC). The potential difference across resistor D is taken to be negative because it is being transversed in the direction of the current. The potential difference across resistor C is taken to be positive because it is being transversed opposite to the direction of the current. The potential difference between the terminals of battery F is taken to be negative because it is being transversed from its positive to its negative terminal. Starting from the lower right corner

$$I_2 R_C - 20 \text{ V} - I_3 R_D = 0$$

$$I_2 (20 \Omega) - 20 \text{ V} - I_3 (30 \Omega) = 0$$

$$20I_2 - 30I_3 = 20 \text{ A}$$

Substituting for I_3 from equation (1) ($I_3 = I_1 - I_2$)

$$20I_2 - 30(I_1 - I_2) = 20 \text{ A}$$

$$-30I_1 + 50I_2 = 20 \text{ A}$$

Substituting for I_2 from equation (2) ($I_2 = 0.3 \text{ A} - 0.5I_1$)

$$-30I_1 + 50(0.3 \text{ A} - 0.5I_1) = 20 \text{ A}$$

$$-55I_1 = 5 \text{ A}$$

$$I_1 = -5/55 \text{ A} = -0.09 \text{ A}$$

The negative sign indicates that the direction of I_1 is opposite to the chosen direction. Current I_2 can be obtained from equation (2).

$$I_2 = 0.3 \text{ A} - 0.5I_1 = (0.3 - 0.5 * -0.09) \text{ A} = 0.345 \text{ A}$$

SMS from your computer

...Sync'd with your Android phone & number

FREE
30 days trial!

Go to

BrowserTexting.com

and start texting from
your computer!

 **BrowserTexting**

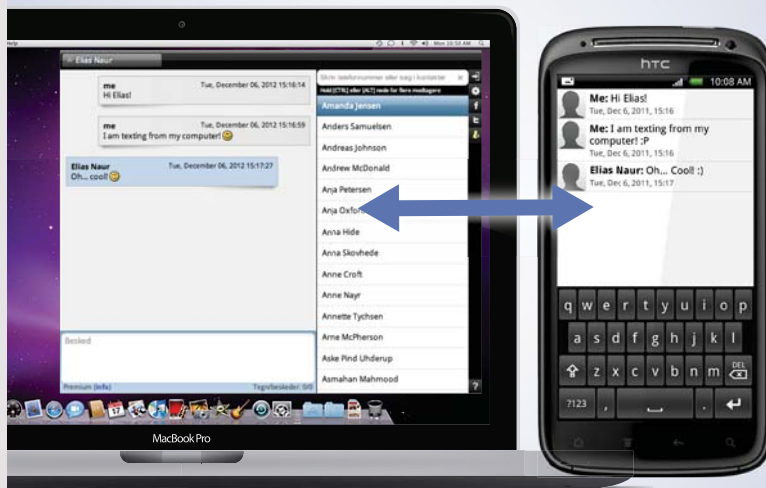

Since the current is positive, the direction of I_2 is the same as the assigned direction. I_3 can be obtained from equation (1).

$$I_3 = I_1 - I_2 = (-0.09 - 0.345) \text{ A} = -0.435 \text{ A}$$

The direction of I_3 is opposite to the assigned direction because it is negative.

Example: Consider Figure 4 again. Resistors A and C have resistances of 5 and 15 ohm. Battery B has an emf of 6 V. There is a current of 2 A in the circuit in the indicated direction (clockwise). Calculate the emf of battery D.

Solution: The unknown emf can be solved by applying the loop rule. The polarity of the unknown emf (the order of its negative and positive terminals) is also unknown. The unknown emf can be assigned an arbitrary polarity. If, after solving the problem, the emf turns out to be positive, then the actual polarity is the same as the chosen polarity; and if it turns out to be negative, the actual polarity is opposite to the chosen polarity. In the diagram, an arbitrary polarity has already been assigned to the unknown emf. The potential differences across both resistors are positive because they are being transversed opposite to the direction of the current. The potential difference across battery B should be positive because it is being transversed from its negative to its positive terminal. The potential difference across battery D should be negative because it is being transversed from its positive to its negative terminal.

$$I = 2 \text{ A}; R_A = 5 \Omega; R_C = 15 \Omega; E_B = 6 \text{ V}; E_D = ?$$

Starting at the lower left corner

$$E_B + IR_C - E_D + IR_A = 0$$

$$6 \text{ V} + 2 * 15 \text{ V} - E_D + 2 * 5 \text{ V} = 0$$

$$E_D = 46 \text{ V}$$

Since E_D turned out to be positive, its actual polarity is the same as the chosen polarity.

4.6 PRACTICE QUIZ 4.2

Choose the best answer. Answers can be found at the back of the book.

- Which of the following is a correct statement?
 - The sum of all currents at a junction of a circuit may or may not be equal to zero
 - The sum of all potential differences in a complete loop is equal to the sum of the potential differences across the batteries in the loop.
 - If a circuit has n simple loops, Kirchoff's loop rule should be applied to n of them.
 - All of the other choices are not correct statements.
 - If a circuit has n junctions, Kirchoff's junction rule should be applied to n of them.
- Which of the following is a correct statement?
 - In applying Kirchoff's junction rule, current in a junction is taken to be positive if it is directed away from the junction.
 - In applying Kirchoff's loop rule, the potential difference across a battery is always taken to be positive.
 - In applying Kirchoff's loop rule, the potential difference across a resistor is taken to be negative if it is transversed in the direction of the current.
 - In applying Kirchoff's loop rule, the potential difference across a resistor is always taken to be negative.
 - In applying Kirchoff's loop rule, the potential difference across a battery is taken to be negative, if it is transversed from the negative to the positive terminal
- This problem is based on Figure 4.4. Resistors A and C have resistances of $13\ \Omega$ and $10\ \Omega$ respectively. Batteries B and D have emfs of $26\ \text{V}$ and $12\ \text{V}$ respectively. Determine the value and the direction of the current in the circuit.
 - $0.609\ \text{A}$ clockwise
 - $0.67\ \text{A}$ counter clockwise
 - $0.67\ \text{A}$ clockwise
 - $0.487\ \text{A}$ counter clockwise
 - $0.609\ \text{A}$ counter clockwise
- This problem is based on Figure 4.4. The current in the circuit is $0.513\ \text{A}$ in the direction indicated (clockwise). Resistors A and C have resistances $13\ \Omega$ and $18\ \Omega$ respectively. Battery D has an emf of $30\ \text{V}$. Determine the value and polarity of the emf of battery B .
 - $14.097\ \text{V}$; polarity same as assumed polarity
 - $15.507\ \text{V}$; polarity opposite to assumed polarity
 - $16.916\ \text{V}$; polarity opposite to assumed polarity
 - $15.507\ \text{V}$; polarity same as assumed polarity
 - $14.097\ \text{V}$; polarity opposite to assumed polarity

5. This problem is based on Figure 4.5. Which of the following represents Kirchoff's junction rule as applied to this circuit? (Wires are represented by numbers 1, 2, and 3.)
- A. $I_1 + I_2 + I_3 = I$
 - B. $I_1 + I_2 + I_3 = 0$
 - C. $I_1 - I_2 + I_3 = 0$
 - D. $I_1 + I_2 - I_3 = 0$
 - E. $I_1 - I_2 - I_3 = 0$
6. This problem is based on Figure 4.5. The current in wire 1 (left wire) is 5 A in the direction shown. The current in wire 2 (middle wire) is 10 A in the direction shown. Calculate the current in wire 3 (right wire).
- A. -15 A
 - B. 15 A
 - C. -5 A
 - D. 5 A
 - E. 0 A

YOUR WORK AT TOMTOM WILL
BE TOUCHED BY MILLIONS.
AROUND THE WORLD. EVERYDAY.

Join us now on www.TomTom.jobs

follow us on **LinkedIn**



#ACHIEVEMORE

TOMTOM 

7. This problem is based on Figure 4.5. Resistors A , C and D have resistances of $11\ \Omega$, $6.5\ \Omega$, and $13.3\ \Omega$ respectively. Batteries B , E and F have emfs of $2.7\ \text{V}$, $15\ \text{V}$ and $10\ \text{V}$ respectively. Which of the following equations represents Kirchoff's loop rule as applied to the left simple loop (starting from the lower left corner).
- A. $-2.7 + 6.5 * I_2 + 15 + 11 * I_1 = 0$
B. $2.7 + 6.5 * I_2 - 15 - 11 * I_1 = 0$
C. $2.7 + 6.5 * I_2 - 15 + 11 * I_1 = 0$
D. $2.7 - 6.5 * I_2 - 15 - 11 * I_1 = 0$
E. $-2.7 + 6.5 * I_2 - 15 + 11 * I_1 = 0$
8. This problem is based on Figure 4.5. Resistors A , C and D have resistances of $17\ \Omega$, $6.5\ \Omega$, and $16.3\ \Omega$ respectively. Batteries B , E and F have emfs of $8.7\ \text{V}$, $9\ \text{V}$ and $16\ \text{V}$ respectively. Which of the following equations represents Kirchoff's loop rule as applied to the right simple loop (starting from the lower right corner).
- A. $-6.5 * I_2 - 16 + 16.3 * I_3 = 0$
B. $-6.5 * I_2 - 16 - 16.3 * I_3 = 0$
C. $-6.5 * I_2 + 16 - 16.3 * I_3 = 0$
D. $6.5 * I_2 - 16 - 16.3 * I_3 = 0$
E. $6.5 * I_2 - 16 + 16.3 * I_3 = 0$
9. This problem is based on Figure 4.5. Resistors A , C and D have resistances of $5\ \Omega$, $9.5\ \Omega$, and $13.3\ \Omega$ respectively. Batteries B , E and F have emfs of $8.7\ \text{V}$, $30\ \text{V}$ and $27.5\ \text{V}$ respectively. Calculate the current through resistor C wire.
- A. $1.226\ \text{A}$
B. $1.05\ \text{A}$
C. $1.751\ \text{A}$
D. $1.576\ \text{A}$
E. $1.401\ \text{A}$
10. This problem is based on Figure 4.5. Resistors A , C and D have resistances of $11.2\ \Omega$, $12.5\ \Omega$, and $24.3\ \Omega$ respectively. The currents through resistors A and C are $0.7\ \text{A}$ and $0.2\ \text{A}$ respectively. Battery B has an emf of $2.7\ \text{V}$. The emfs of batteries E and F respectively are.
- A. $14.344\ \text{V}$ and $-10.615\ \text{V}$
B. $10.432\ \text{V}$ and $-7.72\ \text{V}$
C. $13.04\ \text{V}$ and $-10.615\ \text{V}$
D. $14.344\ \text{V}$ and $-9.65\ \text{V}$
E. $13.04\ \text{V}$ and $-9.65\ \text{V}$

5 MAGNETISM

Your goals for this chapter are to learn about magnetic fields, magnetic forces, magnetic torque, and Ampere's law.

Experiment shows that current carrying objects exert force on each other. The force that exists between objects due to the currents they carry is called *magnetic force*. For example two current carrying wires will exert magnetic forces on each other. The origin of the magnetic force between permanent magnets is the current due to the motion of electrons around the nucleus of the atom. For most of the elements, the currents due to their electrons cancel each other and their atoms are not magnetic. But for some elements such as iron, cobalt and nickel, the currents due to their electrons do not cancel each other and their atoms are magnetic. A sample of a magnetic element such as iron is normally not magnetic even though the atoms of the sample are magnetic. This is because the atomic magnets are distributed randomly and they cancel each other. But if a sample of a magnetic substance is placed near a permanent magnet or a current carrying object, the atomic magnets will be aligned in the same direction and the sample acquires a net magnetic property (that is, it becomes a permanent magnet).

5.1 MAGNETIC FIELD

Magnetic field is a physical quantity used to represent magnetic force. A magnetic substance is assumed to set up magnetic field throughout space and this field exerts magnetic force on a magnetic substance placed at any point in space. Magnetic field is defined to be magnetic force on a current carrying wire per a unit current and per a unit length when the current is perpendicular to the magnetic field. Its unit of measurement is N/A/m which is defined to be the Tesla, abbreviated as T.

5.1.1 MAGNETIC FIELD LINES

Magnetic field lines are lines used to represent magnetic field. The number of lines that cross a unit perpendicular area is drawn in such a way that it is proportional to the magnitude of the magnetic field. The line of action of the magnetic field at a given point is represented by the line of action of the line tangent to the curve at the given point. Arrows are put on the field lines to distinguish between the two possible directions of the tangent line.

5.1.2 MAGNETIC POLES

For permanent magnets of certain shapes, there are two locations where the strength of the magnetic field is the strongest. These locations are called the *Magnetic poles* of the magnet. These two poles are identified as north and south poles. If a magnet is free to rotate across a pivot one of its poles will point towards the North Pole. The pole that points towards the North Pole is identified as the North Pole and the other pole as the South Pole. Experiment shows that similar poles repel and opposite poles attract. The reason a magnet aligns itself along the north South Pole axis (approximately) is because earth has its own magnet aligned along the north-south pole axis. Since the north pole of a magnet points towards the North Pole, the pole of earths magnet located at the North Pole must be a south pole; and the one located at the south pole of earth also must be its north pole.

Magnetic field lines form complete loops. They don't originate somewhere and sink somewhere as electric field lines do. Magnetic field lines come out of the North Pole and come into the south pole of a magnet.



Brain power

By 2020, wind could provide one-tenth of our planet's electricity needs. Already today, SKF's innovative know-how is crucial to running a large proportion of the world's wind turbines.

Up to 25 % of the generating costs relate to maintenance. These can be reduced dramatically thanks to our systems for on-line condition monitoring and automatic lubrication. We help make it more economical to create cleaner, cheaper energy out of thin air.

By sharing our experience, expertise, and creativity, industries can boost performance beyond expectations. Therefore we need the best employees who can meet this challenge!

The Power of Knowledge Engineering

Plug into The Power of Knowledge Engineering.
Visit us at www.skf.com/knowledge

SKF

5.2 MAGNETIC FORCE ON A CHARGE MOVING IN A MAGNETIC FIELD

A moving charge sets up its own magnetic field because motion of a charge is essentially a current. Thus a moving charge placed in a magnetic field due to other sources is acted upon by a magnetic force. The magnitude of the magnetic force (F_B) acting on a charge moving in a magnetic field is proportional to the speed of the charge (v), the strength of the field (B), the charge (q) and the sine of the angle (θ) between the field and the velocity of the charge.

$$F_B = |q|vB \sin(\theta)$$

The direction of the magnetic force is perpendicular to the plane determined by the velocity and magnetic field vectors; That is, the force is directed either perpendicularly out from this plane or perpendicularly into this plane. The directions perpendicularly out and perpendicularly in are symbolically represented by a dot (.) and a cross (x) respectively. To distinguish between the perpendicularly in and out, either the screw rule or the right hand rule can be used.

5.2.1 THE SCREW RULE

To use the screw rule, first join the velocity vector and the field vector tail to tail. Then place a screw at their tails in a direction perpendicular to both vectors. Then rotate the screw from the velocity vector towards the field vector. The direction of movement of the screw has the same direction as the magnetic force if the charge is positive and opposite direction from that of the magnetic force if the charge is negative. A screw goes in if turned clockwise and goes out if turned counter clockwise.

5.2.2 THE RIGHT HAND RULE

To use the right hand rule, first arrange the middle finger and the index finger of the right hand in such a way that the index finger is directed in the direction of the velocity and the middle finger is directed in the direction of the field vector. Then arrange the thumb in such a way that it is perpendicular to both fingers. The thumb points in the direction of the magnetic force if the charge is positive and opposite to the direction of the magnetic force if the charge is negative.

Example: A 4 mC charge is going north-east in a uniform magnetic field of strength 2 T directed towards east with a speed of 600 m/s. Determine the magnitude and direction of the magnetic force acting on the charge.

Solution: Let's use the screw rule to determine the direction. If a screw is placed in direction perpendicular to both the field and the velocity and is turned from the velocity vector (north-east) towards the field vector (east), the screw goes in. Since the charge is positive, the direction of the magnetic force must be perpendicularly in (x).

$$q = 4 \text{ mC} = 4e-3 \text{ C}; v = 600 \text{ m/s}; B = 2 \text{ T}; \theta = 45^\circ; F_B = ?$$

$$F_B = |q|vB \sin(\theta) = 4e-3 * 600 * 2 * \sin(45^\circ) \text{ N} = 3.4 \text{ N}$$

$$\mathbf{F}_B = 3.4 \text{ N perpendicularly in (x).}$$

Example: A -6 nC is moving west with a speed of 3e6 m/s in a region where the magnetic field is directed perpendicularly into the plane of the paper (x). The strength of the magnetic field is 6 mT. Determine the magnitude and direction of the magnetic force acting on the charge.

Solution: Let's use the right hand rule to determine the direction. If the index finger and the middle finger of the right hand are arranged in such a way that the index finger is directed in the direction of the velocity (west) and the middle finger is directed in the direction of the field (perpendicularly in), the thumb points south (down the paper) when arranged to be perpendicular to both fingers. Since the charge is negative, the direction of the magnetic force is opposite to that of the thumb. Thus the direction of the magnetic force is north (towards the top of the paper). The angle between the velocity and the field is 90° because they are perpendicular to each other.

$$q = -6 \text{ nC} = -6e-9 \text{ C}; v = 3e6 \text{ m/s}; B = 6 \text{ mT} = 6e-3 \text{ T}; \theta = 90^\circ; F_B = ?$$

$$F_B = |q|vB \sin(\theta) = 6e-9 * 3e6 * 6e-3 * \sin(90^\circ) \text{ N} = 1.08e-4 \text{ N}$$

$$\mathbf{F}_B = 1.08e-4 \text{ N south}$$

5.2.3 MAGNETIC FORCE ON A CURRENT CARRYING STRAIGHT WIRE PLACED IN A MAGNETIC FIELD

The magnitude of the magnetic force (F_B) on a current carrying straight wire placed in a magnetic field is directly proportional to the current (I), length (l) of the wire, strength of the field (B) and the sine of the angle (θ) between the wire (whose direction is taken to be the direction of the current) and the magnetic field.

$$F_B = IlB \sin(\theta)$$

The direction of the force is perpendicular to the plane determined by the wire and the field. Whether it is perpendicularly out or perpendicularly in can be determined by using the screw rule or the right hand rule. In using the screw rule, the screw should be placed perpendicularly at the intersection of the wire and field and rotated from the wire towards the field. The direction of movement of the screw gives the direction of the magnetic force acting on the wire. In using the right hand rule, the index finger and the middle finger should be aligned in the direction of the wire and the field respectively. When aligned in a direction perpendicular to both fingers, the thumb gives the direction of the magnetic force acting on the wire.



> **Apply now**

REDEFINE YOUR FUTURE
**AXA GLOBAL GRADUATE
PROGRAM 2015**

redefining / standards 

agence.cdg - © Photonistop

Example: A wire of length 1.5 m carrying a current of 3 A to the right is placed in a uniform magnetic field of strength 5 T directed to the left. Determine the magnitude and direction of the magnetic force acting on the wire.

Solution: The angle between the wire and the field is 180° because the current and the field have opposite directions.

$$I = 3 \text{ A}; l = 1.5 \text{ m}; B = 5 \text{ T}; \theta = 180^\circ; F_B = ?$$

$$F_B = IlB \sin(\theta) = 3 * 1.5 * 5 * \sin(180^\circ) \text{ N} = 0$$

No need to specify direction since the force is zero.

$$\mathbf{F}_B = 0$$

Example: A wire of length 2 m carrying a current of 10 A towards south (towards the bottom of the paper) is placed in a 7 T magnetic field whose direction is perpendicularly out of the paper (\odot). Determine the magnitude and direction of the magnetic force acting on the wire.

Solution: Let's use the screw rule to determine the direction. The plane determined by the wire (south) and the field (perpendicularly out) is the plane perpendicular to the plane of this paper. When the screw is put perpendicular to this plane from the right side of the plane and rotated from the wire (south) towards the field, it goes in towards west. Therefore the direction of the magnetic force acting on the wire is west. The angle between the wire and the field is 90° .

$$I = 10 \text{ A}; l = 2 \text{ m}; B = 7 \text{ T}; \theta = 90^\circ; F_B = ?$$

$$F_B = IlB \sin(\theta) = 10 * 2 * 7 \text{ N} = 140 \text{ N}$$

$$\mathbf{F}_B = 140 \text{ N west}$$

5.3 MAGNETIC TORQUE ON A CURRENT CARRYING LOOP PLACED IN A MAGNETIC FIELD

Consider a current carrying rectangular loop placed in a magnetic field directed towards the right. The horizontal parts of the rectangular loop will not experience any force because the angle between the current and the field is zero for one of them and 180° for the other. But the vertical wires experience magnetic force, because the angle between the current and the wire is 90° for both of them. The magnetic forces on the two vertical wires are equal in magnitude but opposite in direction because the directions of the currents are opposite. This creates a rotational effect on the wire that is called magnetic torque. Torque is defined to be the product of force and the perpendicular distance between point of rotation and line of action of force. The unit of measurement of magnetic torque is Nm. The magnetic torque (τ_B) acting on a current carrying loop placed in a magnetic field is proportional to the current, area of the loop (A), strength of the magnetic field, and the sine of the angle between the area of the loop and the field.

$$\tau_B = IAB \sin(\theta)$$

Area is a vector quantity whose magnitude is the area of the loop and whose direction is perpendicular to the plane of the loop. The right hand rule can be used to distinguish between perpendicularly in (x) and perpendicularly out (.). If the fingers are wrapped around the loop in a counter clockwise direction and the thumb is pointing in a direction perpendicular to the fingers, then the direction of area is the same as the direction of the thumb. The direction of area is usually perpendicularly out or the direction pointing towards you.

The direction of magnetic torque is perpendicular to the plane determined by the area vector and the field vector. To distinguish between perpendicularly in and perpendicularly out, either the screw rule or the right hand rule can be used. If using the screw rule, place the screw on the intersection of the area vector and the field vector and then rotate the screw from the area vector towards the field vector. If the direction of the current is counter clockwise, the direction of the magnetic torque is the same as the direction of movement of the screw. If the direction of the current is clockwise, the direction of the torque is opposite to the direction of movement of the screw.

If using the right hand rule, align the index finger and the middle finger along the directions of the area vector and the field vector respectively. Align the thumb in a direction perpendicular to both fingers. The direction of the thumb is the same as the direction of the torque if the direction of current is counter clockwise and opposite to the direction of the magnetic force if the direction of the current is clockwise.

The direction of rotation (that is either clockwise or counter clockwise) and the direction of torque are related by the right hand rule. To use the right hand rule, wrap the fingers around the direction of torque with thumb pointing in the direction of the torque. The direction of rotation is the same as the direction of the fingers.

LIGS University based in Hawaii, USA

is currently enrolling in the
Interactive Online **BBA, MBA, MSc,**
DBA and PhD programs:

- ▶ enroll **by October 31st, 2014** and
- ▶ **save up to 11%** on the tuition!
- ▶ pay in 10 installments / 2 years
- ▶ Interactive **Online education**
- ▶ visit www.ligsuniversity.com to
find out more!

Note: LIGS University is not accredited by any
nationally recognized accrediting agency listed
by the US Secretary of Education.
More info [here](#).



Example: A circular loop of radius 0.2 m and carrying a current of 0.5 A in a counter clockwise direction is placed in the plane of the paper. There is a magnetic field of strength 8 T directed towards the right.

- a) Determine the magnitude and direction of the area of the loop.

Solution: The direction of area can be obtained by wrapping the fingers around the loop in a counter clockwise direction with thumb perpendicular to the fingers. The direction of thumb will be perpendicularly out. Therefore the direction of the area is perpendicularly out.

$$r = 0.2\text{ m}; A = ?$$

$$A = \pi r^2 = 3.14 * 0.2^2\text{ m}^2 = 0.13\text{ m}^2$$

$$\mathbf{A} = 0.13\text{ m}^2 \text{ perpendicularly out } (.)$$

- b) Determine the magnitude and direction of the magnetic torque acting on the wire.

Solution: The direction of the magnetic torque is perpendicular to the plane determined by the area vector (perpendicularly out) and the field vector (right). When a screw placed on the intersection of these vectors perpendicularly and turned from the area vector towards the field vector, the screw moves towards north. Since the direction of the current is counter clockwise, the direction of the torque is the same as the direction of movement of the screw which is north. The angle between the area vector and the field is 90° .

$$I = 0.5\text{ A}; A = 0.13\text{ m}^2; B = 8\text{ T}; \theta = 90^\circ; \tau_B = ?$$

$$\tau_B = IAB \sin(\theta) = 0.5 * 0.13 * 8 * \sin(90^\circ)\text{ Nm} = 0.52\text{ Nm}$$

$$\tau_B = 0.52\text{ Nm north}$$

- c) Is the loop rotating clockwise or counter clockwise about an axis in the direction of the torque?

Solution: The direction of rotation is related with the direction of the magnetic torque by the right hand rule. When thumb points north, the fingers are wrapped in a counter clockwise direction. Therefore the loop is rotating in a counter clockwise direction along an axis in the direction of the torque.

5.4 MASS SPECTROMETER

A *mass spectrometer* is a device that separates a mixture of charged particles according to their masses. When a mixture of charged particles is propelled into a magnetic field, the particles will follow circular trajectories because the magnetic force is perpendicular to the trajectory. Particles with different masses will follow circular trajectories with different radii resulting in the separation of the particles according to their masses.

Suppose a particle of mass m and charge q is propelled into a magnetic field of strength B perpendicularly. It will experience a magnetic force of magnitude $|q|vB$ which is perpendicular to its trajectory and the field. Since the force is perpendicular to the trajectory, the trajectory will be circular. The centripetal force for the circular trajectory is supplied by the magnetic force. Therefore $F_c = mv^2/R = |q|vB$, where R is the radius of the circular trajectory. Solving for R

$$R = mv / (|q|B)$$

Example: A proton (mass $1.67e-27$ kg and charge $1.6e-19$ C) is propelled into a magnetic field of strength 2 T. If it moves in a circular trajectory of radius 0.003 m, calculate the speed with which it was propelled into the field.

Solution: $q = 1.6e-19$ C; $m = 1.67e-27$ kg; $B = 2$ T; $R = 0.003$ m; $v = ?$

$$R = mv / (|q|B)$$

$$v = |q|BR / m = 1.6e-19 * 2 * 0.003 / (1.67e-27) \text{ m/s} = 5.7e5 \text{ m/s}$$

5.5 PRACTICE QUIZ 5.1

Choose the best answer. Answers can be found at the back of the book.

- Which of the following is a correct statement?
 - The cause of the magnetic field due to permanent magnets is earth's magnetic field.
 - Magnetic field lines do not form a complete loop.
 - Magnetic field lines come out of the South Pole and go into the North Pole.
 - The SI unit of measurement for magnetic field is Newton / Ampere.
 - The cause of magnetic force is excess current.

2. Which of the following is a correct statement?
- A. The magnetic force on a current carrying straight wire placed in a magnetic field is directly proportional to the strength of the field.
 - B. The magnetic force on a current carrying straight wire placed in a magnetic field is inversely proportional to the strength of the field.
 - C. Similar poles attract opposite poles repel.
 - D. When a magnet is free to rotate across a pivot, its North Pole points towards the geographic South Pole of earth.
 - E. The magnetic torque acting on a current carrying loop placed in a magnetic field is inversely proportional to the area of the loop.
3. A magnetic force of 8.1 N acts on a 0.0023 C charge when it is moving west with a speed of 110 m/s in a region where the magnetic field is directed south. Calculate the strength of the magnetic field.
- A. 22.411 T
 - B. 38.419 T
 - C. 0 T
 - D. 32.016 T
 - E. 28.814 T

TURN TO THE EXPERTS FOR SUBSCRIPTION CONSULTANCY

Subscribe is one of the leading companies in Europe when it comes to innovation and business development within subscription businesses.

We innovate new subscription business models or improve existing ones. We do business reviews of existing subscription businesses and we develop acquisition and retention strategies.

Learn more at [linkedin.com/company/subscribe](https://www.linkedin.com/company/subscribe) or contact Managing Director Morten Suhr Hansen at mha@subscribe.dk

SUBSCR✓**BE** - to the future

4. A force of 456 N acts on a 0.17 C charge when it moves towards south in a magnetic field of strength 6.5 T directed 30° west of south. How fast is it going?
- A. 660.271 m/s
 - B. 495.204 m/s
 - C. 1072.941 m/s
 - D. 907.873 m/s
 - E. 825.339 m/s
5. Determine the direction of the magnetic force acting on a negative charge going north in a region where the magnetic field is directed perpendicularly into the paper.
- A. perpendicularly out
 - B. perpendicularly in
 - C. south
 - D. west
 - E. east
6. Determine the direction of the magnetic force acting on a straight wire carrying current towards west in a region where the magnetic field is directed perpendicularly out of the paper.
- A. north
 - B. perpendicularly out
 - C. perpendicularly in
 - D. south
 - E. west
7. Calculate the magnitude of the magnetic force acting on a straight wire of length 0.5 m carrying a current of 6.7 A directed towards east placed in a magnetic field of strength 0.77 T directed towards west.
- A. 3.095 N
 - B. 0 N
 - C. 2.837 N
 - D. 2.58 N
 - E. 3.353 N

8. A straight wire of length 2.25 m carrying a current of 5.1 towards east is placed in region where there is 0.92 T field whose direction is 60° north of east. Calculate the magnitude of the magnetic force acting on the wire.
- A. 9.143 N
 - B. 6.4 N
 - C. 7.314 N
 - D. 12.8 N
 - E. 10.057 N
9. A proton is propelled east with a speed of $6.1e6$ m/s to a region where there is a magnetic field of strength 5 T directed perpendicularly out of the paper. Calculate the radius of the resulting circular trajectory of the proton. A proton has a mass of $1.67e-27$ kg and a charge of $1.6e-19$ C.
- A. $0.891e-2$ m
 - B. $1.273e-2$ m
 - C. $1.401e-2$ m
 - D. $1.783e-2$ m
 - E. $1.528e-2$ m
10. A rectangular wire of sides 0.9 m and 0.6 m that carries a current of 1.32 is placed in a region where there is a magnetic field of strength 5.5 T which is parallel to the plane of the loop. Calculate the magnitude of the magnetic torque acting on the wire.
- A. 3.528 N m
 - B. 3.136 N m
 - C. 3.92 N m
 - D. 5.097 N m
 - E. 0 N m
11. A circular loop carrying a current in a counter clockwise direction is placed in a magnetic field directed towards east. If the plane of the loop is parallel to the field, determine the direction of the magnetic torque acting on the loop.
- A. north
 - B. south
 - C. perpendicularly out
 - D. perpendicularly in
 - E. east

5.6 GALVANOMETERS

A *galvanometer* is a device used to measure very small currents and potential differences. The main components of a galvanometer are a permanent magnet and a coil. As current passes through the coil, the coil is acted upon by a magnetic torque and the coil deflects. The coil is connected to a spring; and thus it stops at a certain deflection angle. This deflection angle is proportional to the amount of current that passes through the coil. Therefore, the current can be measured by measuring the deflection angle. If the deflection angle for a certain current is known, the galvanometer can be calibrated to measure currents (or potential differences) over a small range. The maximum deflection of a galvanometer occurs for very small currents and potential differences. It cannot be used to measure real life currents and potential differences. But it can be modified to do so.



"I studied English for 16 years but...
...I finally learned to speak it in just six lessons"

Jane, Chinese architect

ENGLISH OUT THERE

Click to hear me talking before and after my unique course download

5.6.1 CONVERTING A GALVANOMETER TO AN AMMETER

An *ammeter* is a device used to measure currents. An ammeter is connected in series with the part of a circuit whose current is to be measured. A galvanometer can be converted into an ammeter by connecting a small resistance shunt in parallel with the galvanometer. The shunt can be designed in such a way that most of the current in the circuit passes through the shunt and only a small portion of the current passes through the galvanometer. Suppose the maximum deflection of a galvanometer occurs when the current is I_G and we want to convert it to an ammeter whose maximum deflection occurs when the current is I_A . The resistance (R_s) of the shunt should be designed in such a way that only current I_G passes through the galvanometer (of resistance R_G) and the remaining current $I_A - I_G$ passes through the shunt. Since the galvanometer and the shunt are in parallel, their potential difference are equal: $I_G R_G = (I_A - I_G)R_s$. Thus, the resistance of the shunt that should be connected in parallel with the galvanometer to convert it to the required ammeter is given as follows.

$$R_s = I_G R_G / (I_A - I_G)$$

Example: The maximum deflection of a galvanometer of resistance 15 ohm occurs when the current is 0.003 A. Calculate the resistance of the shunt that should be connected in parallel with the galvanometer to convert it to an ammeter whose maximum deflection occurs when the current is 6 A.

Solution: $R_G = 15 \Omega$; $I_G = 0.003 \text{ A}$; $I_A = 6 \text{ A}$; $R_s = ?$

$$R_s = I_G R_G / (I_A - I_G) = 0.003 * 15 / (6 - 0.003) \Omega = 0.0075 \Omega$$

5.6.2 CONVERTING A GALVANOMETER TO A VOLTMETER

A *voltmeter* is a device that is used to measure potential differences. A voltmeter is connected in parallel with the part of a circuit whose potential difference is to be measured. A galvanometer can be converted to a voltmeter by connecting a high resistance shunt in series with the galvanometer. The resistance of the shunt should be designed in such a way that most of the potential difference in the circuit drops across the shunt and only a small portion of the potential difference drops across the galvanometer. Suppose the maximum deflection of the galvanometer occurs when the potential difference is $V_G = I_G R_G$ and we want to convert it to a voltmeter whose maximum deflection is V_V . The resistance of the shunt should be designed in such a way that only a potential difference V_G drops across the galvanometer and the remaining potential difference $V_V - V_G$ drops across the shunt. Since the galvanometer and the shunt are in series, they should have the same current: $V_G/R_G = (V_V - V_G)/R_s$. Therefore, the resistance of the shunt that needs to be connected in series with the galvanometer to convert it to the required voltmeter is given by

$$R_s = (V_V - V_G)R_G/V_G$$

Example: The maximum deflection of a galvanometer of resistance of 5 ohm occurs when the current is 0.002 A. Calculate the resistance of the shunt that needs to be connected in series with the galvanometer to convert it to a voltmeter whose maximum reading is 5 V.

Solution: $I_G = 0.002$ A ($V_G = I_G R_G$); $R_G = 5$ Ω ; $V_V = 5$ V; $R_s = ?$

$$V_G = I_G R_G = 0.002 * 5 \text{ V} = 0.01 \text{ V}$$

$$R_s = (V_V - V_G)R_G/V_G = (5 - 0.01) * 5/0.01 \text{ } \Omega = 2495 \text{ } \Omega$$

5.7 AMPERE'S LAW

Ampere's law is a law that establishes a relationship between currents and the magnetic field they produce. *Ampere's law* states that the summation over a closed path of the product of the tangential component of the magnetic field (B_{\parallel}) at a certain point and a small path element (Δs) evaluated over a closed path is proportional to the total current (I) crossing the closed path.

$$\Sigma B_{\parallel} \Delta s = \mu_0 I$$

μ_0 is a universal constant called magnetic permeability of vacuum. Its value is $4\pi \times 10^{-7} \text{ Tm/A}$

$$\mu_0 = 4\pi \times 10^{-7} \text{ Tm/A}$$

5.7.1 APPLICATIONS OF AMPERE'S LAW

Ampere's law can be used to obtain expressions for the magnetic field due to currents at any point in space. The following are examples of the application of Ampere's law.

5.7.2 MAGNETIC FIELD DUE TO AN INFINITELY LONG STRAIGHT CURRENT CARRYING WIRE

From symmetry, it can be concluded that the magnitude of the magnetic field at all points that are at the same perpendicular distance from the wire is the same. This is because each point can be considered to lie on the perpendicular bisector of the wire since the wire is infinitely long.

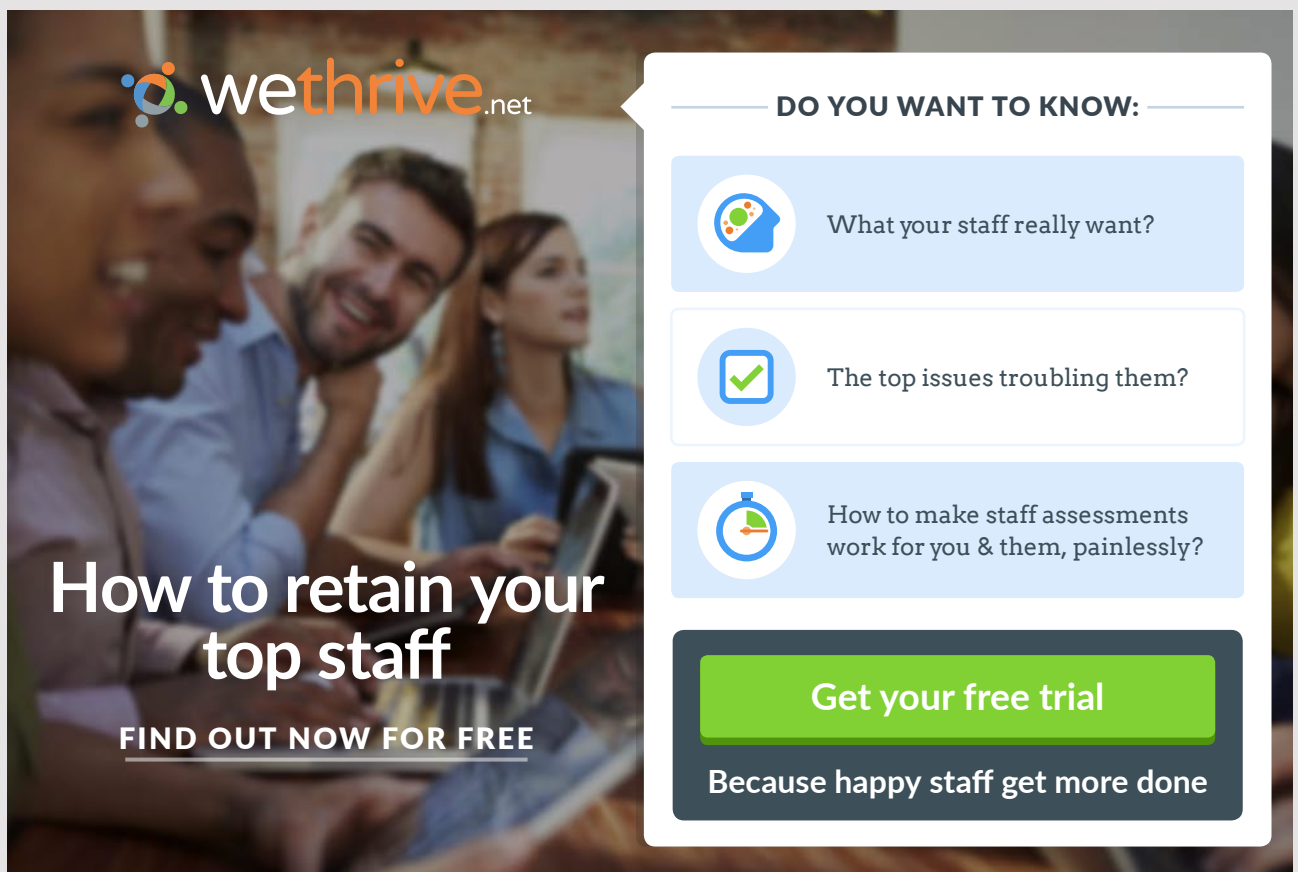

wethrive.net

How to retain your top staff
FIND OUT NOW FOR FREE

DO YOU WANT TO KNOW:

- What your staff really want?
- The top issues troubling them?
- How to make staff assessments work for you & them, painlessly?

Get your free trial
Because happy staff get more done

Experiment shows that a charge moving parallel to the wire is acted upon by a magnetic force perpendicular to its trajectory directed towards or away from the wire perpendicularly. From the screw rule, it follows that the direction of the magnetic field is tangent to a circular path concentric with wire. Therefore the shape of the magnetic field lines must be concentric circles centered at the wire.

Let's apply Ampere's law on a concentric circle of radius r . The tangential component of the field is equal to the magnitude of the field itself because the field is tangent to a concentric circle. Also the magnitude of the field on a concentric circle is a constant. Therefore $\sum B_{\parallel} \Delta s = B \sum \Delta s = B(2\pi r) = \mu_o I$ ($\sum \Delta s$ is equal to the circumference of the concentric circle.). This implies that

$$B = \mu_o I / (2\pi r)$$

B is the magnitude of the magnetic field due to an infinitely long wire carrying a current I at a point a perpendicular distance r from the wire.

The direction of the field at a given point is tangent to a concentric circle passing through the point. To distinguish between the two possible directions of the tangent line, the right hand rule can be used. If the thumb is aligned along the direction of the current and the fingers are wrapped around the wire, then the direction of the fingers gives the direction of the field.

Example: A long straight wire is carrying a current of 2 A to the right

- a) Determine the magnitude and direction of the magnetic field due to the current in the wire at a point 2 m above the wire (on the plane of the paper).

Solution: The direction of the field is tangent to a concentric circle passing through the point. The plane of the concentric circle is perpendicular to the plane of the paper. That means, the direction of the field is either perpendicularly in or perpendicularly out. To distinguish between these two directions, the right hand rule can be used. When the thumb is aligned to the right, the fingers are wrapped in a direction that comes out of the paper. The direction of the field must be perpendicularly out (.).

$$I = 2 \text{ A}; r = 2 \text{ m}; B = ?$$

$$B = \mu_o I / (2\pi r) = 4\pi e-7 * 2 / (2\pi * 2) \text{ T} = 2e-7 \text{ T}$$

$$\mathbf{B} = 2e-7 \text{ T perpendicularly out (.)}$$

- b) Determine the magnitude and direction of the field due to the current in the wire at a point 4 m below the wire (on the plane of the paper)

Solution: The direction of the field is tangent to a concentric circle passing through the point. The plane of the concentric circle is perpendicular to the plane of the paper. That means, the direction of the field is either perpendicularly in or perpendicularly out. To distinguish between these two directions, the right hand rule can be used. When the thumb is aligned to the right, the fingers are wrapped in a direction that goes into the paper. The direction of the field must be perpendicularly in (x).

$$I = 2 \text{ A}; r = 4 \text{ m}; B = ?$$

$$B = \mu_0 I / (2\pi r) = 4\pi e-7 * 2 / (2\pi * 4) \text{ T} = 1e-7 \text{ T}$$

$$\mathbf{B} = 1e-7 \text{ T perpendicularly in (x)}$$

Example: A long straight wire is carrying a current of 5 A perpendicularly into the plane of the paper. Determine the magnitude and direction of the field at a point 2.5 m to the right of the wire.

Solution: The direction of the field is tangent to a concentric circle passing through the point. The plane of the concentric circle is the same as the plane of the paper. Therefore the direction of the field is either north (towards the top of the paper) or south (towards the bottom of the paper). The right hand rule can be used to distinguish between these two directions. If the thumb is directed perpendicularly in, then the fingers are wrapped in a clockwise direction. Therefore the direction of the field must be south.

$$I = 5 \text{ A}; r = 2.5 \text{ m}; B = ?$$

$$B = \mu_0 I / (2\pi r) = 4\pi e-7 * 5 / (2\pi * 2.5) \text{ T} = 4e-7 \text{ T}$$

$$\mathbf{B} = 4e-7 \text{ T south}$$

5.7.3 MAGNETIC FORCE PER UNIT LENGTH BETWEEN TWO CURRENT CARRYING PARALLEL WIRES

Consider two parallel wires separated by a distance d and carrying currents I_1 and I_2 to the right on the plane of the paper with wire 2 being below wire 1. The magnetic field due to wire 1 on the location of wire 2 will exert magnetic force on wire 2. The magnetic field due to wire 1 on the location of wire 2 has a magnitude of $B_{12} = \mu_0 I_1 / (2\pi d)$ and its direction is perpendicularly in. Since the field due to wire 1 on the location of wire 2 and the current of wire 2 are perpendicular to each other, the force per unit length exerted by wire 1 on wire 2 has a magnitude of $F/l = I_2 B_{12}$. Substituting for B_{12}

$$F/l = \mu_0 I_1 I_2 / (2\pi d)$$

From the screw rule, the direction of the magnetic force exerted by wire 1 on wire 2 is towards wire 1; that is wire 1 attracts wire 2. The force exerted by wire 2 on wire 1 will have the same magnitude but opposite direction. Generally, parallel wires carrying currents in the same direction attract each other and parallel wires carrying currents in opposite directions repel each other.

gaiteye[®]
Challenge the way we run

EXPERIENCE THE POWER OF FULL ENGAGEMENT...

.....

**RUN FASTER.
RUN LONGER..
RUN EASIER...**

READ MORE & PRE-ORDER TODAY
WWW.GAITEYE.COM

Example: Two long parallel and horizontal wires are separated by a distance of 0.5 m on the plane of the paper. The upper wire carries a current of 5 A to the right and the lower wire carries a current of 8 A to the left. Determine the magnitude and direction of the force per unit length exerted by the lower wire on the upper wire.

Solution: Since the wires are carrying wires in opposite directions, they repel each other. Therefore the direction of the force exerted by the lower wire on the upper wire must be north.

$$I_1 = 5 \text{ A}; I_2 = 8 \text{ A}; d = 0.5 \text{ m}; F/l = ?$$

$$F/l = \mu_0 I_1 I_2 / (2\pi d) = 4\pi \times 10^{-7} * 5 * 8 / (2\pi * 0.5) \text{ N/m} = 1.6 \times 10^{-5} \text{ N/m}$$

$$F/l = 1.6 \times 10^{-5} \text{ N/m north}$$

5.7.4 MAGNETIC FIELD DUE TO A SOLENOID

A *solenoid* is a coil of a conducting wire. From symmetry considerations, it can be concluded that the magnetic field due to a current carrying solenoid is uniform (and parallel to the axis of the solenoid) inside the solenoid and approximately zero just outside the solenoid.

An expression for the magnetic field due to a solenoid can be obtained by applying Ampere's law to a rectangular path with two of its sides parallel to the solenoid with one of them inside the solenoid and the other outside the solenoid. The sides that are perpendicular to the coil do not contribute to the summation in Ampere's law, because the field is perpendicular to the path element. The side parallel to the solenoid but outside the solenoid also doesn't contribute because the field is zero. Only the inside parallel side contributes. For this side $B_{\parallel} = B$ because the field is parallel to the axis of the solenoid. If the solenoid has N turns, carries a current I and has a length l , Ampere's law gives $\sum B \Delta s = B \sum \Delta s = Bl = \mu_0 NI$. Thus, the magnetic field due to a solenoid is given as

$$B = \mu_0 (N/l)I$$

And if the number of turns per unit length N/l is represented by n

$$B = \mu_0 nI$$

The direction of the field along its axis is related with the direction of the current in the solenoid by the right hand rule. If fingers are wrapped around the solenoid in the direction of the current, thumb points in the direction of the field.

Example: A solenoid of length 0.05 m has 200 turns. It carries a current of 9 A. The direction of the current is clockwise as seen from the side of its right end.

- a) Calculate the field inside the solenoid.

$$l = 0.05 \text{ m}; N = 200; I = 9 \text{ A}; B = ?$$

$$B = \mu_0 (N/l)I = 4\pi \times 10^{-7} * (200/0.05) * 9 \text{ T} = 4.5 \times 10^{-3} \text{ T}$$

- a) Determine whether its north pole is its right end or its left end.

Solution: When the fingers are wrapped around the solenoid in a clockwise direction as seen from the right end, the thumb points towards the left. Therefore the direction of the field must be towards the left. And since magnetic field lines come out of the North Pole, the North Pole is the left end.

5.8 PRACTICE QUIZ 5.2

Choose the best answer. Answers can be found at the back of the book.

- Which of the following is a correct statement?
 - The magnitude of the magnetic field at a given point due to a long current carrying straight wire is inversely proportional to the current flowing in the wire.
 - The magnitude of the magnetic field at a given point due to a long current carrying straight wire is directly proportional to the perpendicular distance between the wire and the point.
 - A galvanometer can be converted to a voltmeter by connecting a high resistance shunt in series with the galvanometer.
 - The magnetic field lines due to a long straight current carrying wire are straight lines parallel to the wire.
 - A galvanometer can be converted to an ammeter by connecting a low resistance shunt in series with the galvanometer.

2. Which of the following is a correct statement?
- A. The magnetic field lines due to a current carrying solenoid inside the solenoid are straight lines parallel to the axis of the solenoid.
 - B. Ampere's law states the magnetic force between two current carrying wires is inversely proportional to the square of the perpendicular distance between the wires.
 - C. The magnetic field due to a current carrying solenoid inside the solenoid is approximately zero.
 - D. The magnetic field strength a point inside a solenoid is inversely proportional to the perpendicular distance between the point and the axis of the solenoid.
 - E. Two long straight wires attract each other if they are carrying currents in opposite directions.

This e-book
is made with
SetaPDF

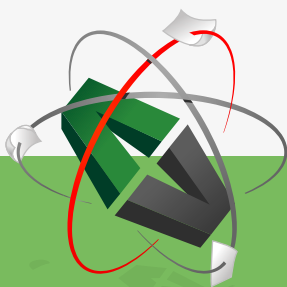

PDF components for PHP developers

www.setasign.com



3. A galvanometer of resistance $30\ \Omega$ acquires its maximum deflection when the current flowing through it is $0.001\ \text{A}$. Calculate the shunt resistance that needs to be connected to the galvanometer to change it to an ammeter whose maximum reading is $14\ \text{A}$.
- A. $1.286e-3\ \Omega$
 - B. $2.572e-3\ \Omega$
 - C. $2.143e-3\ \Omega$
 - D. $1.5e-3\ \Omega$
 - E. $2.357e-3\ \Omega$
4. A galvanometer of resistance $30\ \Omega$ acquires its maximum deflection when the current flowing through it is $0.001\ \text{A}$. Calculate the shunt resistance that needs to be connected to the galvanometer to change it to a voltmeter whose maximum reading is $12\ \text{V}$.
- A. $14.364e3\ \Omega$
 - B. $11.97e3\ \Omega$
 - C. $13.167e3\ \Omega$
 - D. $7.182e3\ \Omega$
 - E. $15.561e3\ \Omega$
5. A long straight wire carrying a current of $6.4\ \text{A}$ towards east lies along the x-axis of an xy-coordinate plane. Determine the magnitude of the magnetic field at a point located on the y-axis at $y = -0.67\ \text{m}$.
- A. $21.015e-7\ \text{T}$
 - B. $15.284e-7\ \text{T}$
 - C. $19.104e-7\ \text{T}$
 - D. $26.746e-7\ \text{T}$
 - E. $13.373e-7\ \text{T}$
6. A long straight wire penetrates the origin of an xy-coordinate plane perpendicularly. If the wire carries a current perpendicularly into the plane, determine the direction of the magnetic field at a point on the y-axis at $y = -2\ \text{m}$.
- A. east
 - B. west
 - C. south
 - D. north
 - E. perpendicularly in

7. Wire A lies horizontally on the x -axis of an xy -coordinate plane and carries a current of 4.5 A to the right. Wire B is parallel to wire A , lies 5.4 m above wire A on the xy -coordinate plane and carries a current of 4.5 A to the right. Determine the magnitude of the force per unit length exerted by wire A on wire B .
- A. $8.25e-7\text{ N/m}$
 - B. $5.25e-7\text{ N/m}$
 - C. $10.5e-7\text{ N/m}$
 - D. $7.5e-7\text{ N/m}$
 - E. $9e-7\text{ N/m}$
8. Wire A lies horizontally on the x -axis of an xy -coordinate plane and carries a current to the right. Wire B is parallel to wire A , lies 1.5 m above wire A on the xy -coordinate plane and carries a current to the left. Determine the direction of the force per unit length exerted by wire A on wire B .
- A. perpendicularly out
 - B. east
 - C. north
 - D. south
 - E. perpendicularly in
9. A solenoid is placed so that its axis lies along the x -axis. It is 0.1 m long and has 550 turns. It carries a current of 12.1 A . Determine the magnitude of the magnetic field inside the solenoid.
- A. $8.363e-2\text{ T}$
 - B. $10.872e-2\text{ T}$
 - C. $10.036e-2\text{ T}$
 - D. $11.708e-2\text{ T}$
 - E. $9.199e-2\text{ T}$
10. A solenoid is placed horizontally. It carries a current which is clockwise as seen from the right end. Determine direction of the magnetic field inside the solenoid.
- A. north
 - B. west
 - C. east
 - D. there is no field
 - E. south

6 INDUCED VOLTAGES AND INDUCTANCE

Your goals for this chapter are to learn about Faraday's law and Lenz's rule.

6.1 FARADAY'S LAW

Magnetic flux (Φ) is a physical quantity used as a measure of the amount of magnetic field that crosses a loop. It is defined to be the product of the perpendicular component of the magnetic field crossing the loop and the area of the loop: $\Phi = B_{\perp} A$. If θ is the angle between the area of the loop and the magnetic field, then $B_{\perp} = B \cos(\theta)$, where B is the magnitude of the field. Therefore

$$\Phi = BA \cos(\theta)$$



Discover the truth at www.deloitte.ca/careers

Deloitte.

© Deloitte & Touche LLP and affiliated entities.

Remember, area is a vector quantity whose direction is perpendicular to the plane of the loop. When fingers are wrapped around the loop in a counter clockwise direction, thumb gives the direction of area. This is usually perpendicularly out. The unit of measurement for magnetic flux is Tm^2 which is sometimes referred as Weber (Wb).

Example: Consider a circular loop of radius 0.04 m on the plane of the paper.

- a) Determine the magnitude and direction of the area of the loop.

Solution: The direction of the area can be obtained from the right hand rule. When fingers are wrapped around the loop in a counter clockwise direction, thumb points perpendicularly out. Thus the direction of the area is perpendicularly out from the plane of the paper (.).

$$r = 0.04; A = ?$$

$$A = \pi r^2 = 3.14 * 0.04^2 \text{ m}^2 = 0.005 \text{ m}^2$$

$$\mathbf{A} = 0.005 \text{ m}^2 \text{ perpendicularly out (.)}$$

- b) Calculate the magnetic flux crossing the loop, when the loop is in a 5 T field directed to the right.

Solution: Since the field is parallel to the plane of the loop and the direction of area is perpendicularly out, the angle between area and field is 90° .

$$A = 0.005 \text{ m}^2; B = 5 \text{ T}; \theta = 90^\circ; \Phi = ?$$

$$\Phi = BA \cos(\theta) = 5 * 0.005 * \cos(90^\circ) \text{ Tm}^2 = 0$$

- c) Calculate the magnetic flux crossing the loop when it is in a 2 T field that penetrates the loop perpendicularly out.

Solution: Since both the area and the field are perpendicularly out, the angle between area and field is zero.

$$A = 0.005 \text{ m}^2; B = 2 \text{ T}; \theta = 0; \Phi = ?$$

$$\Phi = BA \cos(\theta) = 2 * 0.005 * \cos(0) \text{ Tm}^2 = 0.01 \text{ Tm}^2$$

- d) Calculate the magnetic flux crossing the loop when a 0.4 T field penetrates the loop perpendicularly in.

Solution: Since the area is perpendicularly out and the field is perpendicularly in, the angle between the area and the field is 180° .

$$A = 0.005 \text{ m}^2; B = 0.5 \text{ T}; \theta = 180^\circ; \Phi = ?$$

$$\Phi = BA \cos(\theta) = 0.5 * 0.005 * \cos(180^\circ) \text{ Tm}^2 = -0.0025 \text{ Tm}^2$$

Faraday's law: states that whenever there is a change in the magnetic flux crossing a loop, an emf (voltage) will be induced in the loop which is equal to the negative rate of change of flux with time.

$$E_{ind} = -\Delta\Phi / \Delta t = -(\Phi_f - \Phi_i) / \Delta t$$

E_{ind} stands for the induced emf when the flux changes from Φ_i to Φ_f in a time interval Δt . The induced emf will result in induced current in the loop. The direction of the current is counter clockwise if the induced emf is positive and clockwise if the induced emf is negative. Induced emf is positive when the flux decreases and negative when the flux increases (Remember increase of a negative is a decrease). Thus the direction of induced current is counter clockwise when flux decreases and is clockwise when flux increases.

Since magnetic flux depends on the strength of the field, the area of the loop and the angle between area and field, induced emf can be produced by changing, the field strength, the area of the loop or the angle between the area and the field.

Example: A rectangular loop of sides 0.02 m and 0.04 m is placed in a region where there is a 6 mT field penetrating the loop perpendicularly in. The strength of the field is increased to 9 T in 0.2 seconds.

a) Calculate the average induced emf in the loop.

Solution: The direction of the area is perpendicularly out. Therefore the angle between the area and the field is 180° because the direction of the field is perpendicularly in. The area and the angle remain the same. Only the field strength changes.

$$w = 0.02 \text{ m}; l = 0.04 \text{ m} (A_i = A_f = wl); B_i = 6 \text{ T}; B_f = 9 \text{ T}; \theta_i = \theta_f = 180^\circ; \Delta t = 0.2 \text{ s}; E_{ind} = ?$$

$$A_i = A_f = wl = 0.02 * 0.04 \text{ m}^2 = 0.0008 \text{ m}^2$$

$$\Phi_i = B_i A_i \cos(\theta_i) = 6 * 0.0008 * \cos(180^\circ) \text{ Tm}^2 = -0.0048 \text{ Tm}^2$$

$$\Phi_f = B_f A_f \cos(\theta_f) = 9 * 0.0008 * \cos(180^\circ) \text{ Tm}^2 = -0.0072 \text{ Tm}^2$$

$$E_{ind} = -\Delta\Phi / \Delta t = -(\Phi_f - \Phi_i) / \Delta t = -(-0.0072 - -0.0048) / 0.2 \text{ V} = 0.012 \text{ V}$$

© 2013 Accenture. All rights reserved.

be > your degree

Bring your talent and passion to a global organization at the forefront of business, technology and innovation. Discover how great you can be. Visit accenture.com/bookboon

Be greater than.
consulting | technology | outsourcing

accenture
High performance. Delivered.

- b) If the loop has a resistance of $10\ \Omega$, calculate the induced current in the loop. Is the current flowing clockwise or counter clockwise?

Solution: Since the induced emf is positive, the current is flowing counter clockwise.

$$R = 10\ \Omega; I_{ind} = ?$$

$$I_{ind} = E_{ind} / R = 0.012 / 10\ \text{A}; 0.0012\ \text{A}$$

Example: A square loop of side $2\ \text{m}$ is placed in a region where there is a $5\ \text{T}$ field whose direction is perpendicularly out of the plane of the loop. Its shape is changed to a circle in $0.5\ \text{s}$.

- a) Calculate the average induced emf in the loop.

Solution: The angle between the area and the field is zero because the direction for both of them is perpendicularly out. The field strength and the angle remain the same. Only the area is changing. As the shape changes, the perimeter (length of the wire) remains the same. If the side of the square is w and the radius of the circle is r , then $4w = 2\pi r$; and $r = 2w/\pi$.

$$w = 2\ \text{m}; B_i = B_f = 5\ \text{T}; \theta_i = \theta_f = 0; \Delta t = 0.5; E_{ind} = ?$$

$$A_i = w^2 = 2 * 2\ \text{m}^2 = 4\ \text{m}^2$$

$$A_f = \pi r^2 = \pi(2w/\pi)^2 = 4w^2/\pi = 4 * 2^2 / 3.14\ \text{m}^2 = 5.1\ \text{m}^2$$

$$\Phi_i = B_i A_i \cos(\theta_i) = 5 * 4 * \cos(0)\ \text{Tm}^2 = 20\ \text{Tm}^2$$

$$\Phi_f = B_f A_f \cos(\theta_f) = 5 * 5.1 * \cos(0)\ \text{Tm}^2 = 25.5\ \text{Tm}^2$$

$$E_{ind} = -(\Phi_f - \Phi_i) / \Delta t = -(25.5 - 20) / 0.5\ \text{V} = -11\ \text{V}$$

- b) Is the induced current flowing clockwise or counter clockwise?

Solution: It is flowing clockwise because the induced emf is negative.

Example: A square loop of side 0.2 m is placed in a 4 T field that is parallel to the plane of the loop and directed to the right. The loop is rotated about its right side by 90° in 0.4 s so that the plane of the loop is perpendicular to the field. Calculate the average induced emf.

Solution: Initially the direction of the area is perpendicularly out. Thus, the initial angle is 90° because the field is parallel to the plane of the loop. As the loop is rotated, the direction of the area becomes parallel to the plane of the loop directed towards the right (as seen from the right). Therefore the final angle is zero because the field is also directed to the right. The magnitude of the area and the field strength remain the same.

$$w = 0.2 \text{ m } (A_i = A_f = w^2); B_i = B_f = 4 \text{ T}; \theta_i = 90^\circ; \theta_f = 0; \Delta t = 0.4 \text{ s}; E_{ind} = ?$$

$$A_i = A_f = w^2 = 0.2^2 \text{ m}^2 = 0.04 \text{ m}^2$$

$$\Phi_i = B_i A_i \cos(\theta_i) = 4 * 0.04 * \cos(90^\circ) \text{ Tm}^2 = 0 \text{ Tm}^2$$

$$\Phi_f = B_f A_f \cos(\theta_f) = 4 * 0.04 * \cos(0) \text{ Tm}^2 = 0.16 \text{ Tm}^2$$

$$E_{ind} = -(\Phi_f - \Phi_i) / \Delta t = -(0.16 - 0) / 0.4 \text{ V} = -0.4 \text{ V}$$

Example: A loop of radius 0.05 m is placed around a solenoid of radius 0.04 m in such a way that it is concentric with the axis of the solenoid. The solenoid has 300 turns, is 0.06 m long and carries a current of 4 A in a clockwise direction as seen from the right (its axis is horizontal). The current is turned off in 0.004 seconds.

- a) Calculate the average induced voltage in the loop enclosing the solenoid.

Solution: The magnetic field crossing the loop is that due to the solenoid. The field due to a solenoid is approximately zero outside the solenoid. Thus it is only the part of the loop that intersects the solenoid that is being crossed by a magnetic field. This means, in calculating the flux of the loop, the cross-sectional area of the solenoid and not the area of the loop should be used. The field inside a solenoid is given as $B = \mu_0 (N/l)I$. The direction of the area of the loop as seen from the right is to the right. From the right hand rule, the direction of the field inside the solenoid is to the left. Therefore the angle between the area and the field is 180°

$$N = 300; l = 0.06 \text{ m}; I_i = 4 \text{ A}; I_f = 0; r = 0.04 \text{ m}; \theta_i = \theta_f = 180^\circ; \Delta t = 0.004 \text{ s}; E_{ind} = ?$$

$$A_i = A_f = \pi r^2 = 3.14 * 0.04^2 \text{ m}^2 = 0.005 \text{ m}^2$$

$$B_i = \mu_o (N/l)I_i = 4 * 3.14e-7 * (300/0.06) * 4 \text{ T} = 2.5e-2 \text{ T}$$

$$B_f = \mu_o (N/l)I_f = 4 * 3.14e-7 * (300/0.06) * 0 \text{ T} = 0$$

$$\Phi_i = B_i A_i \cos(\theta_i) = 2.5e-2 * 0.005 * \cos(180^\circ) \text{ Tm}^2 = -1.25e-4 \text{ Tm}^2$$

$$\Phi_f = B_f A_i \cos(\theta_f) = 0 * 0.005 * \cos(180^\circ) \text{ Tm}^2 = 0 \text{ Tm}^2$$

$$E_{ind} = -(\Phi_f - \Phi_i) / \Delta t = -(0 - -1.25e-4) / 0.004 \text{ V} = -3.1e-2 \text{ V}$$

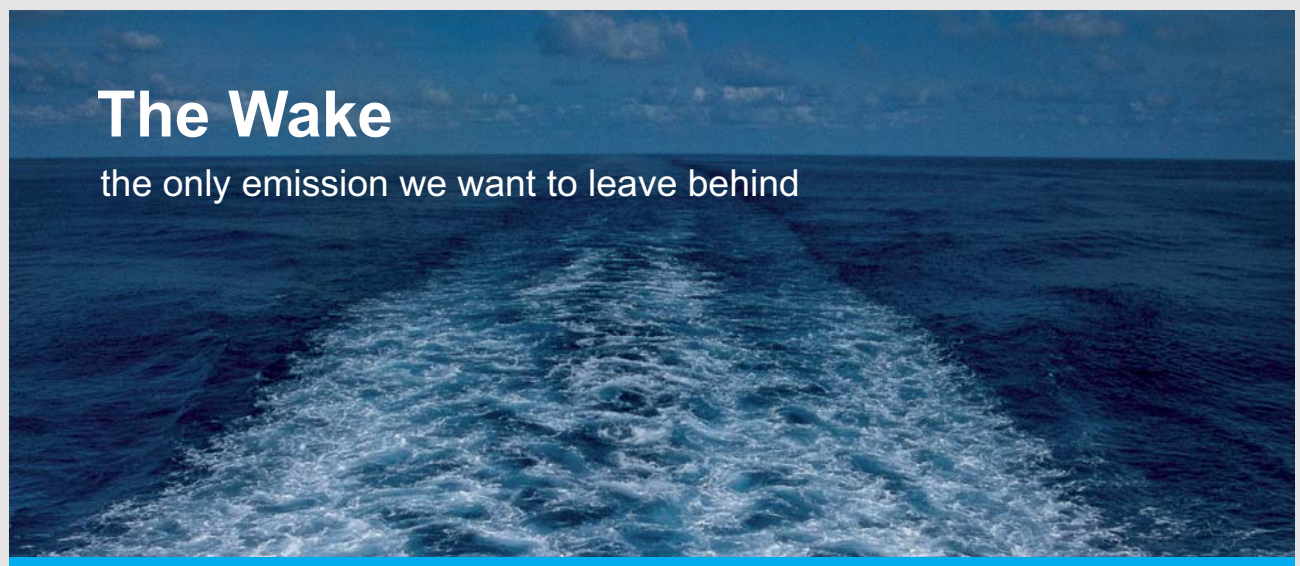

The Wake

the only emission we want to leave behind

Low-speed Engines Medium-speed Engines Turbochargers Propellers Propulsion Packages PrimeServ

The design of eco-friendly marine power and propulsion solutions is crucial for MAN Diesel & Turbo. Power competencies are offered with the world's largest engine programme – having outputs spanning from 450 to 87,220 kW per engine. Get up front! Find out more at www.mandieselturbo.com

Engineering the Future – since 1758.

MAN Diesel & Turbo



- b) Is the induced current in the loop flowing clockwise or counter clockwise as seen from the right?

Solution: Since the induced voltage as seen from the right is negative, the direction of the induced current as seen from the right is clockwise.

6.2 MOTIONAL EMF

Consider a conducting rod of length l sliding with a speed v in a U-shaped conductor (whose width is l). The rod and the closed end of the U-shaped conductor form a complete loop. As the rod slides, the area of this loop changes. If there is a magnetic field crossing the loop, the magnetic flux will change continuously as the area of the loop changes continuously. According to Faraday's law, this change in flux will result in an induced emf in the loop. This kind of induced emf produced by the motion of a rod in a U-shaped conductor placed in a magnetic field is called *motional emf*.

Suppose the U-shaped conductor is placed in a magnetic field of strength B that penetrates its plane perpendicularly and the rod changes its location from x_i to x_f in a time interval Δt . The area of the loop changes from lx_i to lx_f . Thus the absolute value of its motional emf (E_m) is given by $|E_m| = Bl(x_f - x_i) / \Delta t$. But $(x_f - x_i) / \Delta t = v$.

$$|E_m| = Blv$$

Example: A conducting rod of length 0.25 m is sliding in a U-shaped conductor (of width 0.25 m) with a speed of 5 m/s. The U-shaped conductor is placed in a 0.06 T field that penetrates its plane perpendicularly in.

- a) Calculate the absolute value of the motional emf.

Solution: $B = 0.06$ T; $l = 0.25$ m; $v = 5$ m/s; $|E_m| = ?$

$$|E_m| = Blv = 0.06 * 0.25 * 5 \text{ V} = 0.075 \text{ V}$$

- b) If the rod is sliding towards the open end, determine whether the induced current is flowing clockwise or counter clockwise.

Solution: Since the direction of the field is perpendicularly in, the flux is negative (because area is perpendicularly out). As the rod slides towards the open end, the flux becomes more negative or decreases. When flux decreases, induced voltage is positive. When induced voltage is positive, induced current flows in a counter clockwise direction.

6.3 PRACTICE QUIZ 6.1

Choose the best answer. Answers can be found at the back of the book.

1. Which of the following is a correct statement?
 - A. Faraday's law states that whenever the magnetic flux crossing a loop changes, an induced magnetic field is produced in the loop which is equal to the negative rate of change of flux with time.
 - B. The unit of measurement for magnetic flux is Tesla / meter².
 - C. Direction of area of a loop is perpendicular to the plane of the loop.
 - D. Magnetic flux is a vector quantity.
 - E. Magnetic flux crossing a loop is defined to be the product of its area and the component of the magnetic field crossing the loop parallel to the plane of the loop.
2. Which of the following is a correct statement?
 - A. Direction of the area of a loop can be obtained from the right hand rule as the direction of the thumb when fingers are wrapped around the loop in a clockwise direction.
 - B. If a loop on the xy-plane is penetrated by a magnetic field directed perpendicularly into the plane, then the magnetic flux is negative.
 - C. All of the other statements are correct.
 - D. If the magnetic flux crossing a loop increases, then the direction of the induced current in the loop is counter clockwise.
 - E. If the magnetic field crossing a loop is perpendicular to the plane of the loop, then the magnetic flux crossing the loop is zero.

3. A circular loop of radius 0.83 m is placed in a region where there is magnetic field of strength 4 T directed perpendicularly out of the plane of the loop. Calculate the magnetic flux crossing the loop.
- A. 9.523 T m²
B. 0 T m²
C. -9.523 T m²
D. 8.657 T m²
E. -8.657 T m²
4. A square loop of side 0.13 m is placed in a region where there is magnetic field of strength 15 T directed out of the plane of the loop making an angle of 60° with the plane of the loop. Calculate the magnetic flux crossing the loop.
- A. 0.198 T m²
B. 0.22 T m²
C. 0.285 T m²
D. 0.176 T m²
E. 0.307 T m²

SMS from your computer

...Sync'd with your Android phone & number

FREE
30 days trial!

Go to

BrowserTexting.com

and start texting from
your computer!

 BrowserTexting

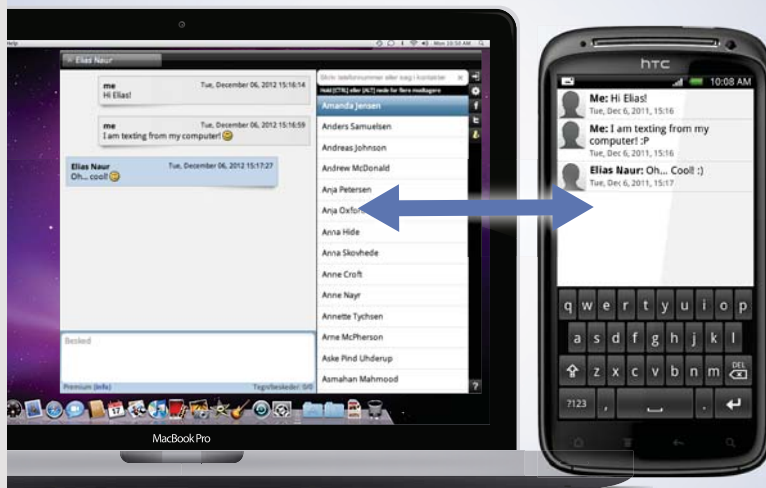

5. A square loop of side 0.45 m is placed in a region where there is a magnetic field of strength 14 T directed perpendicularly out of the plane of the loop. If the magnetic field is decreased to 6 T in 0.08 seconds, calculate the average emf induced in the loop.
- A. 24.3 V
 - B. 20.25 V
 - C. 28.35 V
 - D. 14.175 V
 - E. 18.225 V
6. A square loop of side 0.78 m is placed in a region where there is a magnetic field of strength 19 T directed perpendicularly out of the plane of the loop. If the magnetic field is decreased to 9 T in 0.05 seconds, If the resistance of the loop is 8 Ohm, determine the average current induced in the loop.
- A. 19.773 A
 - B. 21.294 A
 - C. 12.168 A
 - D. 15.21 A
 - E. 13.689 A
7. A square loop of side 0.56 m is placed in a region where there is a magnetic field of strength 18 T directed perpendicularly out of the plane of the loop. If the shape of the square is changed to a circle in 0.9 seconds, calculate the average emf induced in the loop.
- A. -1.885 V
 - B. -1.2 V
 - C. -2.057 V
 - D. -1.714 V
 - E. -2.399 V
8. A square loop of side 0.67 m and resistance 9 Ohm is placed in a region where there is a magnetic field of strength 18 T directed perpendicularly into the plane of the loop. If the shape of the square is changed to a circle in 0.5 seconds, Determine the average current induced in the loop.
- A. 0.491 A
 - B. 0.638 A
 - C. 0.54 A
 - D. 0.589 A
 - E. 0.294 A

9. A square loop of side 0.23 m is placed in a region where there is a magnetic field of strength 5 T directed perpendicularly out of the plane of the loop. If the loop is rotated by 90° in 0.5 seconds so that the plane of the loop is parallel to the field, calculate the average emf induced in the loop.
- A. 0.688 V
 - B. 0.529 V
 - C. 0 V
 - D. 0.635 V
 - E. 0.476 V
10. A square loop of side 0.45 m is placed in a region where there is a magnetic field of strength 2 T directed perpendicularly out of the plane of the loop. The loop is rotated by 90° in 0.7 seconds so that the plane of the loop is parallel to the field. If the resistance of the loop is 10 Ohm, calculate the average induced current in the loop.
- A. 0.064 A
 - B. 0.058 A
 - C. 0.046 A
 - D. 0.041 A
 - E. 0 A
11. A U shaped conductor is placed in a region where there is a magnetic field directed perpendicularly out of the plane of the U shaped conductor. If 6.7 V of emf is induced when a rod of length 1 m slides on the U shaped conductor with a speed of 1.4 m/s, calculate the strength of the field..
- A. 3.829 T
 - B. 4.786 T
 - C. 5.264 T
 - D. 6.7 T
 - E. 3.35 T
12. A solenoid of length 0.065 m, radius 0.015 and number of turns 180 is carrying a current of 4.1 . A circular loop of radius 0.1 m is placed around the solenoid. If the current in the solenoid is reduced to zero in 0.095 seconds, calculate the average emf induced in the loop.
- A. $0.637e-4$ V
 - B. $1.274e-4$ V
 - C. $1.38e-4$ V
 - D. $1.168e-4$ V
 - E. $1.062e-4$ V

6.4 LENZ'S RULE

Lenz's rule states that the direction of the induced current is in such a way as to oppose the cause. If the cause of the induced current is an increase (decrease) of magnetic flux, the direction of the induced current will be in such a way as to decrease (increase) the magnetic flux. For example if an increase in magnetic field is the cause for the increase in magnetic flux, then the direction of the induced current should be in such a way that its induced field opposes the external field so that the magnetic flux decreases.

Example: A U-shaped conductor with its open end to the right is placed in a magnetic field that penetrates its plane perpendicularly out. A rod is sliding on the U-shaped conductor to the right by means of an external force. The change in area of the loop formed by the rod and the closed end of the U-shaped conductor will result in induced emf and hence induced current.

a) What is the cause for the change in flux?

Solution: The cause for the change in flux is the external force pulling the rod to the right causing change in area.

YOUR WORK AT TOMTOM WILL
BE TOUCHED BY MILLIONS.
AROUND THE WORLD. EVERYDAY.

Join us now on www.TomTom.jobs

follow us on **LinkedIn**



#ACHIEVEMORE

TOMTOM 

- b) There will be an induced current in the rod as the rod is moving. A current carrying rod placed in a magnetic field is acted upon by a magnetic force. What should the direction of this force be?

Solution: According to Lenz's rule, the direction of the induced current should be in such a way as to oppose the cause. The cause is the external force to the right. Therefore the direction of the induced current must be in such a way that the direction of the magnetic force is to the left so that it opposes the external force.

- c) Is the induced current flowing down or up the rod?

Solution: Since the magnetic force is to the left and the field is perpendicularly out, from the screw rule or the right hand rule, the induced current must be flowing down the rod (as a screw is turned from the direction of the induced current (down the rod) towards the field (perpendicularly out), it goes to the left).

Example: A loop is pulled away to the right from the north pole of a permanent magnet.

- a) What is the cause for the change in magnetic flux crossing the loop?

Solution: As the loop is pulled away, the strength of the magnetic field crossing it decreases because it is getting further and further from the magnet. Thus, the cause for the change of flux is the decrease in magnetic field.

- b) The change in the flux crossing the loop will produce induced current in the loop and this induced current will produce its own induced field. What should the direction of this induced field be?

Solution: According to Lenz's rule, the direction of the induced current is in such a way as to oppose the cause. Since the cause is decrease in magnetic field, the direction of the induced current must be in such a way as to increase the field. To increase the field, the induced field should be parallel to the field due to the permanent magnet. The field due to the permanent magnet is to the right since magnetic field lines come out of the North Pole. Therefore the direction of the induced field must be to the right.

- c) As seen from the right of the loop, is the induced current flowing clockwise or counter clockwise.

Solution: From the right hand rule for solenoids, when thumb points to the right, fingers are wrapped in a counter clockwise direction when seen from the right. Therefore the induced current is flowing in a counter clockwise direction as seen from the right.

Example: A loop is pushed towards the north pole of a magnet. The North Pole is located on the right end of the magnet.

- a) What is the cause for the change of flux and hence induced current in the loop?

Solution: As the loop is pushed towards the magnet, the strength of the magnetic field crossing the loop gets stronger and stronger because the loop is getting nearer and nearer. Therefore the cause for the induced current is an increase in the strength of the field.

- b) The induced current in the loop will produce its own induced magnetic field. What should the direction of the induced field be?

Solution: Since the cause is an increase in magnetic field, according to Lenz's rule, the direction of the induced current must be in such a way as to decrease the field. To decrease the field, the induced field should oppose the field due to the permanent magnet. The direction of the field due to the permanent magnet is to the right (magnetic field lines come out of the North Pole). Therefore the direction of the induced field must be to the left.

- c) As seen from the right, is the induced current in the loop flowing clockwise or counter clockwise.

Solution: Using the right hand rule for solenoids, when thumb points left fingers are wrapped in a clockwise direction as seen from the right. The induced current is flowing in a clockwise direction as seen from the right.

Example: A loop is put around a solenoid. The solenoid (whose axis is horizontal) carries a current in a clockwise direction as seen from the right. The current is turned off suddenly. As a result there will be a temporary flow of induced current in the loop surrounding the solenoid.

a) What is the cause for the induced current?

Solution: As the current is turned off, the field due to the solenoid suddenly drops to zero. Therefore the cause for the induced current is the decrease of the magnetic field crossing the loop.



Brain power

By 2020, wind could provide one-tenth of our planet's electricity needs. Already today, SKF's innovative know-how is crucial to running a large proportion of the world's wind turbines.

Up to 25 % of the generating costs relate to maintenance. These can be reduced dramatically thanks to our systems for on-line condition monitoring and automatic lubrication. We help make it more economical to create cleaner, cheaper energy out of thin air.

By sharing our experience, expertise, and creativity, industries can boost performance beyond expectations. Therefore we need the best employees who can meet this challenge!

The Power of Knowledge Engineering

Plug into The Power of Knowledge Engineering.
Visit us at www.skf.com/knowledge

SKF

- b) What should be the direction of the induced field due to the induced current in the solenoid?

Solution: Since the cause is decrease of magnetic field, the direction of the induced current must be in such a way as to increase the field. To increase the field, the induced field should have the same direction as the field due to the solenoid. From the right hand rule, the field due to the solenoid is to the left (When fingers are wrapped in a clockwise direction as seen from the right, thumb points to the left). Therefore, the direction of the induced field should be to the left.

- c) As seen from the right, is the induced current in the loop flowing clockwise or counter clockwise.

Solution: Applying the right hand rule, when thumb points to the left, fingers are wrapped in a clockwise direction as seen from the right. Thus, the current is flowing clockwise as seen from the right.

6.5 GENERATORS

A *generator* is a device that converts mechanical energy into electrical energy. Its basic components include a permanent magnet and a coil of conducting wire. As the coil rotates in the magnetic field due to the permanent magnet, the angle between the area of the coil and the field changes giving rise to change in magnetic flux which in turn produces induced voltage.

Let's consider a coil of cross-sectional area A and number of turns N rotating in a magnetic field of strength B with an angular speed of ω . Assuming the area and the field are parallel at $t = 0$, the angle between the area and field at an arbitrary time t is given by $\theta = \omega t$. The following expression gives the flux crossing the coil at an arbitrary time t (The flux crossing the coil is equal to N times the flux crossing one turn).

$$\Phi = NBA \cos(\omega t)$$

The induced voltage is equal to the negative rate of change of the flux with time (In the language of calculus, the induced voltage is equal to the negative derivative of flux with time: $E_{ind} = -d\Phi/dt$). Using calculus, the following expression for the induced voltage of a generator at an arbitrary time can be obtained.

$$E_{ind} = NBA\omega \sin(\omega t)$$

The maximum value of the voltage (amplitude) is equal to $E_{max} = NBA\omega$. The time taken for one complete oscillation (period) is equal to $T = 2\pi/\omega$. The number of cycles executed per second is equal to $f = \omega/(2\pi)$

Example: The coil of a generator has 400 turns and a cross sectional area of $4e-3 \text{ m}^2$. It is rotating in a field of strength 3 T with an angular speed of 5 rad/s.

- a) Calculate the maximum value of the induced voltage.

Solution: $N = 400$; $B = 3 \text{ T}$; $A = 4e-3 \text{ m}^2$; $\omega = 5 \text{ rad/s}$; $E_{max} = ?$

$$E_{max} = NBA\omega = 400 * 3 * 4e-3 * 5 \text{ V} = 24 \text{ V}$$

-
- b) How long does it take to make one complete cycle?

Solution: $T = ?$

$$T = 2\pi/\omega = 2 * 3.14/5 \text{ s} = 1.3 \text{ s}$$

-
- c) How many cycles does it execute per second?

Solution: $f = ?$

$$f = 1/T = 1/1.3 \text{ Hz} = 0.77 \text{ Hz}$$

d) Calculate the instantaneous voltage after 10 s.

Solution: $t = 10$; $E_{ind} = ?$

$$E_{ind} = E_{max} \sin(\omega t) = 24 * \sin(5 * 10) \text{ V} = -6.3 \text{ V}$$

6.6 INDUCTORS

An *inductor* is a coil (like a solenoid). Its circuit symbol is a coil. As current passes through an inductor, magnetic field is produced inside the inductor. If the current flowing in the inductor changes, the field inside the coil changes giving rise to the change of the magnetic flux crossing the coil which in turn produces induced voltage. This kind of induced voltage in a coil produced by its own current is called *self-induced emf* (E_{self}). The self-induced emf in a coil is proportional to the negative rate of change of its own current with time. The constant of proportionality between the induced voltage and the negative rate of change of current is called the inductance (L) of the coil.

$$E_{self} = -L \Delta I / \Delta t = -L(I_f - I_i) / \Delta t$$



> **Apply now**

REDEFINE YOUR FUTURE
**AXA GLOBAL GRADUATE
PROGRAM 2015**

redefining / standards 

agence.cdg - © Photonistop

The unit of measurement for inductance is Vs / A which is defined to be the Henry, abbreviated as H. The inductance of an inductor depends only on the geometry of the coil.

Example: The current through a 5 mH inductor changed from 4 A to 2 A in 0.4 s. Calculate the average self-induced emf in the inductor.

Solution: $L = 5 \text{ mH} = 5 \times 10^{-3} \text{ H}$; $I_i = 4 \text{ A}$; $I_f = 2 \text{ A}$; $\Delta t = 0.4$; $E_{\text{self}} = ?$

$$E_{\text{self}} = -L \Delta I / \Delta t = -L(I_f - I_i) / \Delta t = -5 \times 10^{-3} * (2 - 4) / 0.4 \text{ V} = 2.5 \times 10^{-2} \text{ V}$$

6.6.1 INDUCTANCE OF A SOLENOID

Consider a solenoid of length l and cross-sectional radius R with N turns. If the solenoid is carrying current I , then the field inside the solenoid is given as $B = \mu_0 (N/l)I$. The field and the cross-sectional area have the same direction (or possibly opposite) since the direction of the field inside a solenoid is along the axis of the solenoid (that is $\theta = 0$). Thus, the flux crossing the solenoid is given as $\Phi = NBA = N\mu_0 (N/l)I\pi R^2$. If the current is changing with time, then the self-induced emf is given by $E_{\text{self}} = -\mu_0 (N^2/l) \pi R^2 \Delta I / \Delta t = -L\Delta I / \Delta t$. Solving for L from this equation yields the inductance of a solenoid as a function of its geometry.

$$L = \mu_0 \pi N^2 R^2 / l$$

6.7 PRACTICE QUIZ 6.2

Choose the best answer. Answers can be found at the back of the book.

- Which of the following is a correct statement?
 - The unit of measurement for the inductance of an inductor is Ampere / second
 - A generator is a device that converts electrical energy to mechanical energy.
 - The self-induced emf in an inductor is proportional to the rate of change of the current flowing in the inductor.
 - Lenz's rule states that the direction of the induced current due to change of flux is in such a way as to enforce the cause.
 - All of the other statements are correct.

2. If the cause for an induced current in a loop is a decrease in the magnetic flux crossing the loop, then the direction of the induced current will be in such a way as to
 - A. All of the other choices are correct.
 - B. increase the magnetic flux
 - C. eliminate the magnetic flux
 - D. decrease the magnetic flux
 - E. None of the other choices are correct.

3. A U shaped conductor is placed in a region where there is magnetic field directed perpendicularly out of the plane of the loop. When a conducting rod slides on the U shaped conductor to the right, then the direction of the magnetic force acting on the rod due to the induced current is
 - A. none of the other choices are correct
 - B. to the left
 - C. to the right
 - D. down
 - E. up

4. A U shaped conductor is placed (with its open end to the right) in a region where there is a magnetic field directed perpendicularly into the plane of the loop. When a conducting rod slides to the left, the direction of the induced current is
 - A. down the rod (south)
 - B. up the rod (north)
 - C. all of the other choices are correct
 - D. none of the other choices are correct
 - E. there is no current

5. A permanent magnet is placed horizontally with the right end being its North Pole. A conducting loop is pushed to the left towards the North Pole. The direction of the induced magnetic field due to the induced current in the loop is
 - A. there is no induced field
 - B. cannot be determined
 - C. to the right
 - D. to the left
 - E. none of the other choices are correct

6. A permanent magnet is placed horizontally with the right end being its South Pole. A conducting loop is pulled away from the right end to the right. The direction of the induced current in the loop as seen from the right of the loop is
- A. cannot be determined
 - B. counter-clockwise
 - C. There is no induced current
 - D. None of the other choices are correct.
 - E. clockwise
7. A solenoid is placed horizontally. The current in the solenoid is counter-clockwise as seen from the right end. A conducting loop is wrapped around the solenoid (concentric with the solenoid). If the current is decreased, the direction of the induced magnetic field due to the induced current in the loop is cannot be determined
- A. There is no induced field
 - B. None of the other choices are correct.
 - C. to the right
 - D. to the left

LIGS University based in Hawaii, USA

is currently enrolling in the
Interactive Online **BBA, MBA, MSc,**
DBA and PhD programs:

- ▶ enroll **by October 31st, 2014** and
- ▶ **save up to 11%** on the tuition!
- ▶ pay in 10 installments / 2 years
- ▶ Interactive **Online education**
- ▶ visit www.ligsuniversity.com to
find out more!

Note: LIGS University is not accredited by any
nationally recognized accrediting agency listed
by the US Secretary of Education.
More info [here](#).



8. A solenoid is placed horizontally. The current in the solenoid is counter-clockwise as seen from the right end. A conducting loop is wrapped around the solenoid (concentric with the solenoid). If the current is decreased, the direction of the induced current in the loop as seen from the right is
- A. None of the other choices are correct.
 - B. cannot be determined
 - C. clockwise
 - D. there is no induced current
 - E. counter-clockwise
9. The coil of a generator is a square of side 0.15 m and has 240 turns. It is placed in a 3.45 T magnetic field and is rotating with an angular speed of 22 rad / s. Calculate the amplitude (maximum) of the voltage produced by the generator.
- A. 532.818 V
 - B. 409.86 V
 - C. 368.874 V
 - D. 327.888 V
 - E. 573.804 V
10. When the current in an inductor changes from 5 A to 6 A in 0.51 s, 4 V of average voltage is induced. Calculate the inductance of the inductor.
- A. 2.04 H
 - B. 1.632 H
 - C. 1.428 H
 - D. 1.836 H
 - E. 1.224 H

7 ALTERNATING CURRENT CIRCUITS

Your goals for this chapter are to learn about alternating current circuits involving a resistor, an inductor and a capacitor.

An alternating current circuit (ac) is a circuit where the voltage and the current vary with time typically like a sine or a cosine. A typical ac signal may be given as $v = V \sin(\omega t + \beta)$. v is the voltage at a given instant of time and is called instantaneous voltage. V is the maximum value of the voltage and is called the amplitude of the voltage. ω is the number of radians executed per second and is called the angular frequency of the voltage. It is related with frequency (f) as $\omega = 2\pi f$ and with period (T) as $\omega = 2\pi/T$. β is called the phase angle of the voltage. Its effect is to shift the graph of $\sin(\omega t)$ either to the right (if negative) or to the left (if positive).

Phase angle of signal 2 minus the phase angle of signal 1 is called the *phase shift* (θ) of signal 2 with respect to signal 1. The one with a bigger phase angle is said to be leading the other and the one with a smaller phase angle is said to be lagging from the other. If $v_1 = V_1 \sin(\omega t + \beta_1)$ and $v_2 = V_2 \sin(\omega t + \beta_2)$, then

$$\theta = \beta_2 - \beta_1$$

Example: An ac voltage varies with time according to the equation $v = 120 \text{ V} \sin(300t + \pi/2)$

- a) What is the maximum value of the voltage?

Solution: $V = ?$

$$V = 120 \text{ V}$$

-
- b) How long does it take to make one complete oscillation?

Solution: $\omega = 300 \text{ rad/s}$; $T = ?$

$$T = 2\pi/\omega = 2 * 3.14/300 \text{ s} = 0.021 \text{ s}$$

c) What is its phase angle?

Solution: $\beta = ?$

$$\beta = \pi/2$$

Example: Calculate the phase shift between the following pair of signals and indicate which one is leading: $v_1 = 10 \text{ V sin}(20t + \pi)$ and $v_2 = 20 \text{ V sin}(20t - \pi/2)$

Solution: $\beta_1 = \pi$; $\beta_2 = -\pi/2$; $\theta = ?$

$$\theta = \beta_2 - \beta_1 = -\pi/2 - \pi = -3\pi/2$$

v_1 is leading because its phase angle is bigger.

TURN TO THE EXPERTS FOR **SUBSCRIPTION** CONSULTANCY

Subscribe is one of the leading companies in Europe when it comes to innovation and business development within subscription businesses.

We innovate new subscription business models or improve existing ones. We do business reviews of existing subscription businesses and we develop acquisition and retention strategies.

Learn more at [linkedin.com/company/subscribe](https://www.linkedin.com/company/subscribe) or contact Managing Director Morten Suhr Hansen at mha@subscribe.dk

SUBSCR✓**BE** - to the future

7.1 A RESISTOR CONNECTED TO AN AC SOURCE

Let's consider a resistor of resistance R connected to an ac source whose voltage varies with time according to the equation $v = V \sin(\omega t)$. Ohm's law applies to ac circuits instantaneously. Therefore the equation $v = iR$ holds where i stands for the instantaneous current. This implies that

$$i = (V/R) \sin(\omega t) \text{ when } v = V \sin(\omega t)$$

This shows that, in a resistor, the phase shift (θ_R) between the voltage and the current is zero. In other words, the voltage and the current are in phase.

$$\theta_R = 0$$

Where $\theta_R = \beta_v - \beta_i$ is the phase shift of voltage with respect to current for a resistor. Since $i = I \sin(\omega t) = (V/R) \sin(\omega t)$, Ohm's law also applies to the amplitudes of the voltage and the current.

$$V = IR$$

Example: A resistor of resistance 50 ohm is connected to an ac source whose potential difference varies with time according to the equation $v = 20 \text{ V} \sin(100t)$.

- a) Calculate the amplitude of the current.

Solution: $V = 20 \text{ V}$; $R = 50$; $I = ?$

$$I = V/R = 20/50 \text{ A} = 0.4 \text{ A}$$

-
- b) Give a formula for the instantaneous current as a function of time.

Solution: $\omega = 100 \text{ rad/s}$; $i(t) = ?$

$$i(t) = I \sin(\omega t) = 0.4 \text{ A} \sin(100t)$$

c) Calculate the instantaneous voltage and current after 10 s.

Solution: $t = 10$ s; $i = ?$; $v = ?$

$$i = I \sin(\omega t) = 0.4 * \sin(100 * 10) \text{ A} = 0.33 \text{ A}$$

$$v = V \sin(\omega t) = 20 * \sin(100 * 10) \text{ V} = 16.5 \text{ V}$$

7.2 A CAPACITOR CONNECTED TO AN AC SOURCE

Let's consider a capacitor of capacitance C connected to an ac source whose potential difference varies with time according to the equation $v = V \sin(\omega t)$. The instantaneous charge q of the capacitor is related with the instantaneous voltage by $q = vC$. The instantaneous current is equal to the rate of change of the charge or the derivative of charge with respect to time in the language of calculus. Therefore, using calculus (because it can't be done algebraically), $i = dq/dt = C dv/dt = C d\{V \sin(\omega t)\}/dt = CV\omega \cos(\omega t)$. But $\cos(\omega t) = \sin(\omega t + \pi/2)$

$$i = CV\omega \sin(\omega t + \pi/2) \text{ when } v = V \sin(\omega t)$$

This implies that for a capacitor, the voltage lags from the current by $\pi/2$ or 90° .

$$\theta_C = \beta_v - \beta_i = -\pi/2$$

Where θ_C is the phase shift of the voltage with respect to current for a capacitor. Since $i = I \sin(\omega t + \pi/2) = CV\omega \sin(\omega t + \pi/2)$,

$$I = CV\omega$$

Where I is the amplitude of the current. The ratio between the amplitude of the voltage across a capacitor and the amplitude of the current across a capacitor is defined to be the **capacitive reactance** (X_C) of the capacitor.

$$X_C = V/I$$

The unit of measurement for capacitive reactance is ohm. Replacing I by $VC\omega$, it follows that the capacitive reactance of a capacitor is inversely proportional to the frequency of the voltage (current).

$$X_C = 1/(\omega C)$$

Example: A capacitor of capacitance $20 \mu\text{F}$ is connected to an ac source whose potential difference varies with time according to the equation $v = 12 \text{ V } \sin(500t)$.

a) Calculate its capacitive reactance.

Solution: $C = 20 \mu\text{F} = 2e-5 \text{ F}$; $\omega = 500 \text{ rad/s}$; $X_C = ?$

$$X_C = 1/(\omega C) = 1/(500 * 2e-5) \Omega = 100 \Omega$$

b) Calculate the amplitude of the current.

Solution: $V = 12 \text{ V}$; $I = ?$

$$I = V/X_C = 12/100 \text{ A} = 0.12 \text{ A}$$



"I studied English for 16 years but...
...I finally learned to speak it in just six lessons"

Jane, Chinese architect

ENGLISH OUT THERE

Click to hear me talking before and after my unique course download

c) Give a formula for the current as a function of time.

Solution: For a capacitor, the current leads the voltage by $\pi/2$. Therefore, since the phase angle of the voltage is zero, the phase angle of the current must be $\pi/2$.

$$\theta_c = -\pi/2; i(t) = ?$$

$$i = I \sin(\omega t - \theta_c) = 0.12 \text{ A } \sin(500t + \pi/2)$$

7.3 AN INDUCTOR CONNECTED TO AN AC SOURCE

Let's consider an inductor of inductance L connected to an ac source where the current in the circuit varies with time according to the equation $i = I \sin(\omega t)$. From Kirchoff's loop rule, the voltage of the source is the negative of the self-induced voltage (so that they add up to zero): $v = -E_{\text{self}}$. But $E_{\text{self}} = -L di/dt$ (using calculus). Hence $v = L di/dt = L d\{I \sin(\omega t)\}/dt = L\omega I \cos(\omega t)$. And $\cos(\omega t) = \sin(\omega t + \pi/2)$.

$$v = L\omega I \sin(\omega t + \pi/2) \text{ when } i = I \sin(\omega t)$$

This means, for an inductor, the voltage leads the current by $\pi/2$ or 90° .

$$\theta_L = \pi/2$$

Where $\theta_L = \beta_v - \beta_i$ is the phase shift of the voltage with respect to the current. Since $v = V \sin(\omega t + \pi/2) = L\omega I \sin(\omega t + \pi/2)$,

$$V = L\omega I$$

The ratio between the amplitude of the voltage across an inductor and the current across the inductor is called the *inductive reactance* (X_L) of the inductor.

$$X_L = V/I$$

The unit of measurement for inductive reactance is the ohm. Replacing V by $L\omega I$, it is seen that the inductive reactance of an inductor is directly proportional to the frequency of the signal.

$$X_L = \omega L$$

Example: An inductor of inductance 15 mH is connected to an ac source whose potential difference varies with time according to the equation $v = 40 \text{ V sin } (250t)$.

- a) Calculate its inductive reactance.

Solution: $\omega = 250 \text{ rad/s}$; $L = 15 \text{ mH} = 0.015 \text{ H}$; $X_L = ?$

$$X_L = \omega L = 250 * 0.015 \text{ } \Omega = 3.75 \text{ } \Omega$$

- b) Calculate the amplitude of the current.

Solution: $I = ?$

$$I = V/X_L = 40/3.75 \text{ A} = 10.7 \text{ A}$$

- c) Give a formula for the current as a function of time.

Solution: For an inductor, the current lags from the voltage by $\pi/2$ and the phase angle of the voltage is zero. The phase angle of the current must be $-\pi/2$.

$\theta_L = \pi/2$; $i(t) = ?$

$$i(t) = I \text{ sin } (\omega t - \theta_L) = 10.7 \text{ A sin } (250t - \pi/2)$$

7.4 PRACTICE QUIZ 7.1

Choose the best answer. Answers can be found at the back of the book.



1. A certain signal varies with time according the equation $x = 6 * \text{sin } (45t + 1.5)$. The angular frequency of the signal is.
A. 3.14
B. 6
C. 6.28
D. 45
E. 1.5

2. Which of the following is a correct statement?
- A. For a resistor connected to an ac signal, the voltage leads the current by 90° .
 - B. For a capacitor connected to an ac signal, the current leads the voltage by 90° .
 - C. The capacitive reactance of a capacitor is proportional to the frequency of the ac signal to which it is connected to
 - D. The inductive reactance of an inductor is inversely proportional to the frequency of the ac signal to which it is connected to.
 - E. For an inductor connected to an ac signal, the current leads the voltage by 90° .
3. A certain signal varies with time according the equation $x = 4 * \sin (30t + 0.25)$. How long does it take to make one complete cycle?
- A. 0.147 s
 - B. 0.209 s
 - C. 0.126 s
 - D. 0.251 s
 - E. 0.188 s

wethrive.net

How to retain your top staff
FIND OUT NOW FOR FREE

DO YOU WANT TO KNOW:

-  What your staff really want?
-  The top issues troubling them?
-  How to make staff assessments work for you & them, painlessly?

Get your free trial
Because happy staff get more done

4. Identify the pair of signal for which x is leading y .
- A. $x = 20 \sin (40t - 2)$
 $y = \sin (40t)$
- B. $x = 20 \sin (40t - 1)$
 $y = \sin (40t - 3)$
- C. $x = 20 \sin (40t - 1)$
 $y = \sin (40t + 1)$
- D. $x = 20 \sin (40t + 1)$
 $y = \sin (40t + 3)$
- E. $x = 20 \sin (40t)$
 $y = \sin (40t + 3)$
5. When a resistor of resistance 15.3 Ohm is connected to a sinusoidal ac voltage, a current that varies with time according the equation $i = 0.95 \text{ A} * \sin (300t)$ flows in the circuit. Calculate the amplitude of the voltage across the resistor.
- A. 8.721 V
- B. 14.535 V
- C. 10.175 V
- D. 13.082 V
- E. 17.442 V
6. A resistor of resistance 44.7 Ohm is connected to an ac voltage that varies with time according to the equation $71 \text{ V} * \sin (100t)$. Give a formula for the instantaneous current as a function of time.
- A. $1.588 \text{ A} * \sin (100t - 1.57)$
- B. $1.43 \text{ A} * \sin (100t + 1.57)$
- C. $1.588 \text{ A} * \sin (100t)$
- D. $1.43 \text{ A} * \sin (100t)$
- E. $1.588 \text{ A} * \sin (100t + 1.57)$
7. An inductor has an inductive reactance of 620 Ohm when connected to an ac voltage of frequency 170 Hz . Calculate the inductance of the inductor.
- A. 0.58 H
- B. 0.464 H
- C. 0.406 H
- D. 0.638 H
- E. 0.813 H

8. When an inductor of inductance 0.035 H is connected to a sinusoidal ac voltage, a current that varies with time according the equation $i = 2.5 \text{ A} * \sin(45t)$. Give a formula for the instantaneous voltage as a function of time.
- A. $3.938 \text{ V} * \sin(45t + 1.57)$
 - B. $3.938 \text{ V} * \sin(45t)$
 - C. $3.544 \text{ V} * \sin(45t)$
 - D. $3.938 \text{ V} * \sin(45t - 1.57)$
 - E. $3.544 \text{ V} * \sin(45t + 1.57)$
9. A capacitor has an capacitive reactance of 83 Ohm when connected to an ac voltage of frequency 140 Hz. Calculate its capacitive reactance when connected to an ac voltage of frequency 90 Hz.
- A. 129.111 Ohm
 - B. 116.2 Ohm
 - C. 154.933 Ohm
 - D. 180.756 Ohm
 - E. 90.378 Ohm
10. A capacitor of capacitance 0.053 F is connected to an ac voltage that varies with time according the equation $v = 4.0 \text{ V} * \sin(12.5t)$. Calculate the amplitude of the current through the capacitor.
- A. 1.855 A
 - B. 3.71 A
 - C. 2.915 A
 - D. 3.18 A
 - E. 2.65 A

7.5 SERIES COMBINATION OF A RESISTOR, AN INDUCTOR AND A CAPACITOR CONNECTED TO AN AC SOURCE

Let's consider a series combination of a resistor of resistance R , an inductor of inductance L and a capacitor of capacitance C connected to an ac source where the current in the circuit varies with time according the equation $i = I \sin(\omega t)$. The currents through the resistor (i_R), the inductor (i_L) and the capacitor (i_C) are equal and they are equal to the current in the circuit.

$$i_R = i_L = i_C = i = I \sin(\omega t)$$

The net instantaneous potential difference (v) is equal to the sum of the instantaneous potential differences across the resistor (v_R), the inductor (v_L) and capacitor (v_C).

$$v = v_R + v_L + v_C$$

In a resistor, the voltage and the current are in phase; that is, their phase angles are equal. Therefore, since $i = I \sin(\omega t)$, the instantaneous potential difference across the resistor is given by

$$v_R = V_R \sin(\omega t)$$

Where $V_R = IR$. In an inductor, the voltage leads the current by $\pi/2$; that is, the phase angle of the voltage is $\pi/2$ more than the phase angle of the current. Since the current is given as $i = I \sin(\omega t)$, the instantaneous potential difference across the inductor is given by

$$v_L = V_L \sin(\omega t + \pi/2)$$

gaiTEYE[®]
Challenge the way we run

**EXPERIENCE THE POWER OF
FULL ENGAGEMENT...**

.....

**RUN FASTER.
RUN LONGER..
RUN EASIER...**

READ MORE & PRE-ORDER TODAY
WWW.GAITEYE.COM

Where $V_L = IX_L$. In a capacitor, the potential difference lags from the current by $\pi/2$; that is the phase angle of the voltage is $\pi/2$ less than the phase angle of the current. Since the current is given as $i = I \sin(\omega t)$, the instantaneous voltage across the capacitor is given by

$$v_C = V_C \sin(\omega t - \pi/2)$$

Where $V_C = IX_C$. The net instantaneous voltage is the sum of the instantaneous voltages across the resistor, inductor and capacitor: $v = V_R \sin(\omega t) + V_L \sin(\omega t + \pi/2) + V_C \sin(\omega t - \pi/2)$. But $\sin(\omega t + \pi/2) = \cos(\omega t)$ and $\sin(\omega t - \pi/2) = -\cos(\omega t)$. Therefore, $v = V_R \sin(\omega t) + (V_L - V_C) \cos(\omega t)$. Also, if the phase shift of the net voltage with respect to the current is θ , then

$$v = V \sin(\omega t + \theta)$$

This expression of v can be expressed in terms of $\cos(\omega t)$ and $\sin(\omega t)$ by expanding the sine: $v = V \cos(\theta) \sin(\omega t) + V \sin(\theta) \cos(\omega t)$. The coefficients of $\cos(\omega t)$ and $\sin(\omega t)$ of both expressions of v can be equated because $\cos(\omega t)$ and $\sin(\omega t)$ are independent functions.

$$V_R = V \cos(\theta) \dots (1)$$

$$V_L - V_C = V \sin(\theta) \dots (2)$$

An expression for the phase shift of the voltage with respect to the current can be obtained by dividing equation (2) by equation (1): $\sin(\theta) / \cos(\theta) = \tan(\theta) = (V_L - V_C) / V_C = (IX_L - IX_C) / (IR) = (X_L - X_C) / R$. Thus θ is given as follows:

$$\theta = \arctan \{(X_L - X_C) / R\} = \{[\omega L - 1 / (\omega C)] / R\}$$

An expression for the amplitude of the net voltage can be obtained by squaring equations (1) and (2) and adding: $V_R^2 + (V_L - V_C)^2 = \{V \cos(\theta)\}^2 + \{V \sin(\theta)\}^2 = V^2$. Therefore, the amplitude of the net voltage is related with the amplitudes of the voltages across the resistor, inductor and capacitor as follows:

$$V = \sqrt{V_R^2 + (V_L - V_C)^2}$$

The total **impedance** (Z) of the series combination is defined to be the ratio between the between the amplitude of the net voltage and the amplitude of the current in the circuit.

$$Z = V / I$$

An expression for Z in terms of R , L , C can be obtained by expressing the voltages in terms of the current: $Z = V/I = \sqrt{\{(IR)^2 + (IX_L - IX_C)^2\}}/I$. Hence,

$$Z = \sqrt{R^2 + (X_L - X_C)^2} = \sqrt{R^2 + [\omega L - 1/(\omega C)]^2}$$

Example: A 200Ω resistor, a 20 H inductor and a 5 mF capacitor are connected in series and then connected to an ac source whose potential difference varies with time according to the equation $v = 120 \text{ V} \sin(15t)$.

a) Calculate the impedance of the circuit.

Solution: $R = 200 \Omega$; $L = 20 \text{ H}$; $C = 5 \text{ mF} = 5 \times 10^{-3} \text{ F}$; $\omega = 15 \text{ rad/s}$; $Z = ?$

$$Z = \sqrt{R^2 + [\omega L - 1/(\omega C)]^2} = \sqrt{200^2 + (15 * 20 - 1/15/5 \times 10^{-3})^2} \Omega = 349.5 \Omega$$

b) Calculate the amplitude of the current.

Solution: $V = 120 \text{ V}$; $I = ?$

$$I = V/Z = 120/349.5 \text{ A} = 0.343 \text{ A}$$

c) Calculate the amplitudes of the voltages across the resistor, inductor and capacitor.

Solution: $V_R = ?$; $V_L = ?$; $V_C = ?$

$$V_R = IR = 0.343 * 200 \text{ V} = 68.6 \text{ V}$$

$$V_L = IX_L = I\omega L = 0.343 * 15 * 20 \text{ V} = 102.9 \text{ V}$$

$$V_C = IX_C = I/(\omega C) = 0.343 / (15 * 5 \times 10^{-3}) \text{ V} = 4.6 \text{ V}$$

d) Calculate the phase shift of the voltage with respect to the current. Which one is leading?

Solution: $\theta = ?$

$$\theta = \arctan \{ [\omega L - 1/(\omega C)] / R \} = \arctan \{ [15 * 20 - 1/(15 * 5e-3)] / 200 \} \text{ deg} = 55^\circ$$

Or

$$\cos(\theta) = V_R / V$$

$$\theta = \arccos(V_R / V) = \arccos(68.6 / 120) \text{ deg} = 55^\circ$$

Since the phase shift of voltage with respect to current ($\theta = \beta_v - \beta_i$) is positive, the voltage is leading.

This e-book
is made with
SetaPDF



PDF components for PHP developers

www.setasign.com

e) Obtain a formula for the current as a function of time.

Solution: Since the voltage leads the current by θ and the phase angle of the voltage is zero, the phase angle of the current should be $-\theta$

$$\theta = 55^\circ = 55 \cdot 3.14 / 180 \text{ rad} = 0.96 \text{ rad}; \beta_i = 0 \text{ (because } v = V \sin(\omega t)); i(t) = ?$$

$$\theta = \beta_v - \beta_i$$

$$\beta_i = \beta_v - \theta = 0 - 0.96 = -0.96$$

$$i(t) = I \sin(\omega t + \beta_i) = 0.343 \text{ A} \sin(15t - 0.96)$$

f) Obtain formulas for the voltages across the resistor, inductor and capacitor as a function of time.

$$\textit{Solution: } \theta_R = 0; \theta_L = \pi/2; \theta_C = -\pi/2; v_R(t) = ?; v_L(t) = ?; v_C(t) = ?$$

$$\theta_R = \beta_{Rv} - \beta_i$$

$$\beta_{Rv} = \theta_R + \beta_i = 0 + -0.96 = -0.96$$

$$v_R = V_R \sin(\omega t + \beta_{Rv}) = 68.6 \text{ V} \sin(15t - 0.96) \quad \theta_L = \beta_{Lv} - \beta_i$$

$$\beta_{Lv} = \theta_L + \beta_i = \pi/2 + -0.96 = \pi/2 - 0.96$$

$$v_L = V_L \sin(\omega t + \beta_{Lv}) = 102.9 \text{ V} \sin(15t + \pi/2 - 0.96) \quad \theta_C = \beta_{Cv} - \beta_i$$

$$\beta_{Cv} = \theta_C + \beta_i = -\pi/2 + -0.96 = -\pi/2 - 0.96$$

$$v_C = V_C \sin(\omega t + \beta_{Cv}) = 4.6 \text{ V} \sin(15t - \pi/2 - 0.96)$$

7.5.1 RESONANT FREQUENCY

The Amplitude of the current through a series connection of a resistor, an inductor and capacitor depends on the frequency of the source, because the impedance of the combination depends on frequency. The frequency for which the amplitude of the current is the maximum for a given amplitude of the voltage is called *resonant frequency* of the circuit. Since $I = V/Z$, I is maximum when Z is minimum. Since $Z = \sqrt{\{R^2 + [\omega L - 1/(\omega C)]^2\}}$, Z is minimum when $\omega L - 1/(\omega C) = 0$. Therefore the resonant angular frequency (ω_o) is the frequency that makes this expression zero.

$$\omega_o = 1/\sqrt{LC}$$

The resonant frequency is obtained by dividing the resonant angular frequency by 2π ; that is, $f_o = 1/\{2\pi \sqrt{LC}\}$. Resonant frequency has a very important application in the tuning circuits of radios, televisions and others. A tuning circuit may have a variable capacitor. The capacitance of the variable capacitor can be dialed so that the resonant frequency of the tuning circuit is equal to the frequency of the signal to be picked. When signals with different frequencies arrive on the device, only the signal whose frequency is equal to the resonant frequency will be received with a significant current.

Example: The tuning circuit of a radio consists of a series combination of a 1000Ω resistor, 0.004 H and a variable capacitor. To what capacitance should the capacitor be dialed, if the radio is to pick a signal whose frequency is $2e6$ Hz.

Solution: The capacitance of the capacitor should be dialed to a value that makes the resonant frequency of the tuning circuit equal to the frequency of the signal to be picked.

$$f_o = 2e6 \text{ Hz}; L = 0.004 \text{ H}; C = ?$$

$$f_o = 1/\{2\pi \sqrt{LC}\}$$

$$f_o^2 = 1/(4\pi^2 LC)$$

$$C = 1/(4\pi^2 f_o^2 L) = 1/(4 * 3.14^2 * 2e6^2 * 0.004) \text{ F} = 1.6e-12 \text{ F}$$

7.5.2 ROOT MEAN SQUARE VALUE

The *root mean square (RMS) value* of an ac signal is defined to be the square root of the average of the square of the signal. Let's consider an ac voltage that varies with time according to the equation $v = V \sin(\omega t)$. Squaring $v^2 = V^2 \sin^2(\omega t)$. The square of the sine can be expanded using the double angle formula: $v^2 = V^2/2 - V^2 \cos(2\omega t)/2$. The average of the first term is itself $V^2/2$ because it is a constant. The average of the second term is zero because cosine alternates between equal (numerically) positives and negatives periodically. Therefore the RMS value (V_{RMS}) of an ac signal is equal to the square root of $V^2/2$; that is, the RMS value of an ac signal is obtained by dividing the amplitude by $\sqrt{2}$.

$$V_{RMS} = V/\sqrt{2}$$

Similarly the RMS value of the current is given as $I_{RMS} = I/\sqrt{2}$. ac voltmeters and ammeters are designed to measure RMS values.



Discover the truth at www.deloitte.ca/careers

Deloitte.

© Deloitte & Touche LLP and affiliated entities.

Example: An ac voltmeter connected to an ac voltage reads 10 V. What is the amplitude of the voltage.

Solution: The reading of the voltmeter is equal to the RMS value of the voltage.

$$V_{RMS} = 10 \text{ V}; V = ?$$

$$V = \sqrt{2} V_{RMS} = \sqrt{2} * 10 \text{ V} = 14.1 \text{ V}$$

7.5.3 AVERAGE POWER

The instantaneous power dissipated in ac circuits is given as the product of the instantaneous voltage and instantaneous current. Suppose the current varies with time in the form $i = I \sin(\omega t)$ and the phase shift of the voltage with respect to the current is θ . Then, the voltage is given as $v = V \sin(\omega t + \theta)$ and the instantaneous power varies with time as $VI \sin(\omega t) \sin(\omega t + \theta) = VI \cos(\theta) \sin^2(\omega t) + VI \sin(\theta) \sin(\omega t) \cos(\omega t)$ (the last expression is obtained by expanding $\sin(\omega t + \theta)$). The average of the first term is $VI \cos(\theta)/2$ because the average of $\sin^2(\omega t)$ is equal to $1/2$ as obtained in the previous section. The average of the second term is zero because $\sin(\omega t) \cos(\omega t) = \sin(2\omega t)/2$ whose average is zero because sine alternates between equal (numerically) positives and negatives periodically. Therefore, the average power (P_{av}) of an ac circuit is given as follows:

$$P_{av} = IV \cos(\theta)/2 = I_{RMS} V_{RMS} \cos(\theta)$$

The value $\cos(\theta)$ is called the power factor of the circuit. The circuit yields no power if the phase shift of voltage with respect to current is $\pm \pi/2$ (because $\cos(\pi/2) = 0$). For example, no power can be extracted from an inductor or a capacitor because their phase shifts are $\pi/2$ and $-\pi/2$ respectively. Only a resistor yields power because for a resistor the phase shift is zero and $\cos(0) = 1$. Actually, it can be said that the power dissipated in a series connection of a resistor, inductor and capacitor, the power dissipated in the circuit is equal to the power dissipated in the resistor. Since $\cos(\theta) = V_R/V = IR/V$, the average power can also be written as

$$P_{av} = I^2 R / 2 = I_{RMS}^2 R$$

Example: A $500\ \Omega$ resistor, a $60\ \text{H}$ inductor and a $0.006\ \text{F}$ capacitor are connected in series and then connected to a potential difference that varies with time according to the equation $v = 20\ \text{V} \sin(20t)$.

- a) Calculate the average power dissipated in the circuit.

Solution: $V = 20\ \text{V}$; $\omega = 20\ \text{rad/s}$; $R = 500\ \Omega$ $L = 60\ \text{H}$; $C = 0.006\ \text{F}$; $I = ?$ ($P_{av} = I^2 R/2$); $P_{av} = ?$

$$I = V/Z = V/\sqrt{\{R^2 + [\omega l - 1/(\omega C)]^2\}} = 20/\sqrt{\{500^2 + [20 * 60 - 1/(20 * 0.006)]^2\}} \text{ A} = 0.015\ \text{A}$$

$$P_{av} = I^2 R/2 = 0.015^2 * 500/2\ \text{W} = 0.06\ \text{W}$$

- b) Calculate the average power dissipated across the resistor, inductor and capacitor.

Solution: The power dissipated across the resistor is equal to the power dissipated in the circuit which is $0.06\ \text{W}$. The power dissipated across the inductor is zero because the phase shift of voltage with respect to current is $\pi/2$. The average power dissipated across the capacitor is zero because the phase shift of the voltage with respect to current is $-\pi/2$.

7.6 PRACTICE QUIZ 7.2

Choose the best answer. Answers can be found at the back of the book.

- Which of the following is a correct statement?
 - The RMS value of an ac signal is the average of the signal.
 - The power factor of an RLC series ac circuit is equal to the sine of the phase shift between the voltage and the current.
 - The resonant frequency of the series connection of a resistor, inductor and capacitor connected to an ac signal is the frequency of the signal for which the amplitude of the voltage is maximum.
 - Power cannot be delivered by a capacitor
 - Power can be delivered by an inductor.

2. The maximum possible power is dissipated in an RLC series circuit when the phase shift between the voltage and the current is
- A. 30°
 - B. 0°
 - C. 60°
 - D. 45°
 - E. 90°
3. Calculate the amplitude of an ac voltage whose RMS value is 20 V .
- A. 14.142 V
 - B. 40 V
 - C. 10 V
 - D. 28.284 V
 - E. 20 V

© 2013 Accenture. All rights reserved.

be > your degree

Bring your talent and passion to a global organization at the forefront of business, technology and innovation. Discover how great you can be.

Visit accenture.com/bookboon

Be greater than.
consulting | technology | outsourcing

accenture
High performance. Delivered.

4. What will be the reading of an ac ammeter connected to an ac signal that varies with time according to the equation $v = 7 \text{ A} \sin(100t)$.
- A. 4.95 A
 - B. 14 A
 - C. 7 A
 - D. 9.899 A
 - E. 3.5 A
5. A 5 Ohm resistor, a 0.7 H inductor and a 0.07 F capacitor are connected in series and then connected to an ac potential difference that varies with time according to the equation $v = 10 \text{ V} \sin(18t)$. Calculate the impedance of the circuit.
- A. 8.975 Ohm
 - B. 17.95 Ohm
 - C. 10.257 Ohm
 - D. 14.104 Ohm
 - E. 12.821 Ohm
6. A 2 Ohm resistor, a 0.7 H inductor and a 0.06 F capacitor are connected in series and then connected to an ac potential difference that varies with time according to the equation $v = 6 \text{ V} \sin(12t)$. Calculate the amplitude of the current in the circuit.
- A. 0.823 A
 - B. 0.741 A
 - C. 0.576 A
 - D. 1.152 A
 - E. 0.988 A
7. A 10 Ohm resistor, a 0.2 H inductor and a 0.07 F capacitor are connected in series and then connected to an ac potential difference that varies with time according to the equation $v = 8 \text{ V} \sin(26t)$. Calculate the phase shift of the net voltage with respect to the current.
- A. 22.044°
 - B. 24.941°
 - C. 16.176°
 - D. 17.006°
 - E. 19.179°

8. A $4\ \Omega$ resistor, a $0.2\ \text{H}$ inductor and a $0.08\ \text{F}$ capacitor are connected in series and then connected to an ac potential difference that varies with time according to the equation $v = 80\ \text{V} \sin(26t)$. Calculate the power dissipated in the circuit.
- A. $434.792\ \text{W}$
 - B. $401.347\ \text{W}$
 - C. $301.01\ \text{W}$
 - D. $468.238\ \text{W}$
 - E. $334.456\ \text{W}$
9. A resistor, an inductor and a capacitor are connected in series and then connected to a sinusoidal ac voltage. The amplitudes of the potential differences across the resistor, the inductor and the capacitor are $31\ \text{V}$, $32\ \text{V}$ and $36\ \text{V}$ respectively. Calculate the amplitude of the net potential difference of the circuit.
- A. $31.257\ \text{V}$
 - B. $25.006\ \text{V}$
 - C. $40.634\ \text{V}$
 - D. $18.754\ \text{V}$
 - E. $28.131\ \text{V}$
10. A resistor, an inductor and a capacitor are connected in series and then connected to a sinusoidal ac voltage of amplitude $16\ \text{V}$. If the amplitude of the voltage across the resistor is $4\ \text{V}$, calculate the phase shift of the net voltage with respect to the current.
- A. 67.97°
 - B. 75.522°
 - C. 105.731°
 - D. 52.866°
 - E. 60.418°

11. A $10\ \Omega$ resistor, a $0.007\ \text{H}$ inductor and a $0.008\ \text{F}$ capacitor are connected in series and then connected to an ac signal. What should the frequency of the signal be if the amplitude of the current is to be maximum?
- A. $29.775\ \text{Hz}$
 - B. $27.648\ \text{Hz}$
 - C. $23.395\ \text{Hz}$
 - D. $17.014\ \text{Hz}$
 - E. $21.268\ \text{Hz}$
12. The tuning circuit of a radio consists of a $3e-3\ \text{H}$ inductor and a variable capacitor connected in series. To what capacitance should the capacitor be dialed if the radio is to pick a signal from a radio station that broadcasts at a frequency of $5e3\ \text{Hz}$.
- A. $43.906e-8\ \text{F}$
 - B. $0.27e-8\ \text{F}$
 - C. $37.151e-8\ \text{F}$
 - D. $27.019e-8\ \text{F}$
 - E. $33.774e-8\ \text{F}$

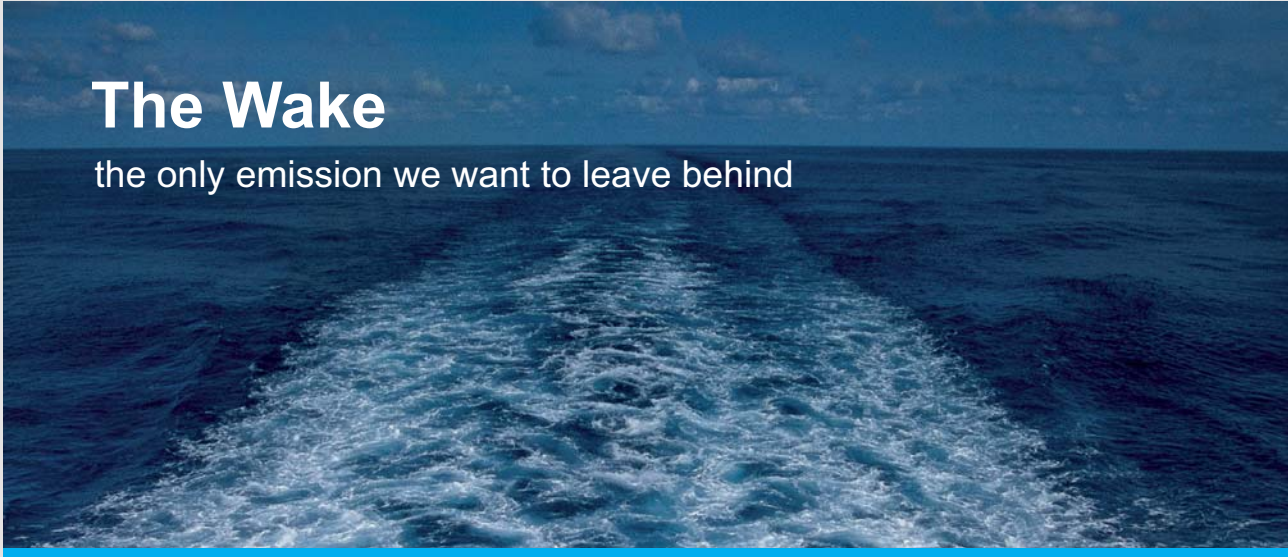

The Wake

the only emission we want to leave behind

Low-speed Engines Medium-speed Engines Turbochargers Propellers Propulsion Packages PrimeServ

The design of eco-friendly marine power and propulsion solutions is crucial for MAN Diesel & Turbo. Power competencies are offered with the world's largest engine programme – having outputs spanning from 450 to 87,220 kW per engine. Get up front! Find out more at www.mandieselturbo.com

Engineering the Future – since 1758.

MAN Diesel & Turbo



8 LIGHT AND OPTICS

8.1 THE HISTORY OF LIGHT

In the seventeenth century, Isaac Newton stated that light is made up of corpuscles (particles). But later it was found out that light displays wave properties, and Christian Huygens stated that light is a wave. In the mid nineteenth century, Maxwell developed the four equations of electricity and magnetism known as Maxwell's equations. Based on these equations, Maxwell showed that light is a small subset of a large group of waves called electromagnetic waves. This established the wave nature of light firmly. But in the late nineteenth century and early twentieth century, some experiments that contradicted classical physics were done. These were the black body radiation experiment, the photoelectric experiment and the Michelson-Morley experiment. Max Planck found out that the findings of the black body radiation can be explained only if he assumes that light is propagated in the form of particles. His assumptions were confirmed by subsequent experiments mainly the photoelectric experiment. The current understanding of light is that light is both a particle and wave. This means in some experiments it behaves like a wave and in some experiments like a particle. This is called the dual property of light.

8.1.1 THE WAVE NATURE OF LIGHT

The wave nature of light is best described by means of Maxwell's equations. Maxwell's equations are four equations that encompass the vast experimental findings of electricity and magnetism. The first equation is a representation of Coulomb's law which deals with the force between charged objects. The second equation is a mathematical representation of the fact that magnetic field lines form complete loops. The third equation is a representation of Ampere's law modified by theoretical prediction of Maxwell. Ampere's Law states that current gives rise to magnetic field and Maxwell's theoretical prediction states a time varying electric field produces magnetic field. The fourth equation is a representation of Faraday's law which states that a time varying magnetic field produces electric field or induced emf.

By combining these equations, Maxwell was able to predict that whenever a charge is accelerated, electromagnetic wave is propagated. This theoretical prediction was tested for the first time by the German scientist by the name Hertz (the unit of frequency was named Hertz in honor of this scientist) who produced electromagnetic waves by accelerating charges. This was put into practical application for the first time by the Italian inventor Marconi who invented the radio. Today electromagnetic waves are a part of our daily life. Radio signals, television signals, cellphone signals and others are carried by electromagnetic waves.

All electromagnetic waves have the same speed which is the speed of light. The speed of light (c) in vacuum is $3e8$ m/s.

$$c = 3e8 \text{ m/s}$$

Electromagnetic waves are classified according to their wavelengths. The range of wavelengths that produce sensation of vision are called light waves. The range of wavelengths that produce sensation of heat are called infrared waves. The range of wavelengths that are used to carry radio signals are called radio waves. Other examples include x-rays (used in medicine to obtain pictures of internal body parts), ultraviolet rays (which produces vitamin D in our bodies) and Gamma radiation (which is the most energetic radiation).

The physical quantities that vary as a function of position and time for electromagnetic waves are electric field and magnetic field. The electric field and the magnetic field are perpendicular to each other and to the direction of propagation of energy. Since electromagnetic waves are waves, they satisfy the wave equation.

$$c = f \lambda$$

Where f is frequency and λ is wavelength.

Example: Violet light has a wavelength of 400 nm. Calculate its frequency.

Solution: $\lambda = 400 \text{ nm} = 400e-9 \text{ m} = 4e-7 \text{ m}; f = ?$

$$f = c/\lambda = 3e8/4e-7 \text{ Hz} = 7.5e14 \text{ Hz}$$

8.1.2 PARTICLE NATURE OF LIGHT

The black body radiation experiment is an experiment that studied the intensity distribution of the different wavelengths emitted by a hot object. A graph of intensity as a function of wavelength was obtained. Classical physics failed to explain the results of this experiment. Max Planck has to state the following two postulates to explain the experiment:

1. Light is propagated in the form of particles called photons.
2. The energy of a photon is directly proportional to the frequency of light.

If E is the energy of a photon and f is the frequency of the light, then

$$E = hf$$

h is a universal constant called Planck's constant. Its value is $6.6e-34$ Js.

$$h = 6.6e-34 \text{ Js}$$

For light containing a number of photons, the total energy is obtained by multiplying the energy of one photon by the number of photons.

$$E_n = nbf$$

Where n is the number of photons and E_n is the energy of n photons. Max Planck's postulates were confirmed by the findings of the photoelectric experiment which was explained by Albert Einstein. These postulate gave rise to the formation of a new branch of physics called quantum mechanics. Quantum mechanics has been used successfully at the atomic level.

SMS from your computer

...Sync'd with your Android phone & number

FREE
30 days trial!

Go to

BrowserTexting.com

and start texting from
your computer!

 BrowserTexting

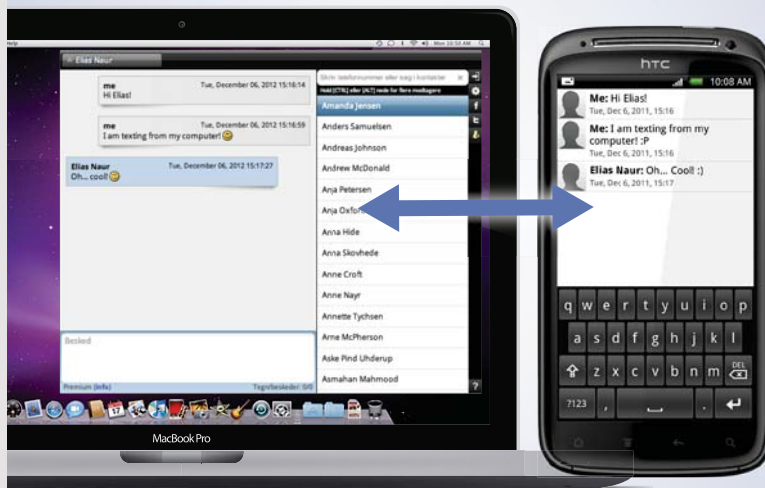

Example: Calculate the energy of 5000 photons of red light. The wavelength of red light is 700 nm.

Solution: $n = 5000$; $\lambda = 700 \text{ nm} = 7e-7 \text{ m}$ ($f = c/\lambda$); $E_n = ?$

$$f = c/\lambda = 3e8/7e-7 \text{ Hz} = 4.3e14 \text{ Hz}$$

$$E_n = nhf$$

$$E_{5000} = 5000 * 6.6e-34 * 4.3e14 \text{ J} = 1.3e-15 \text{ J}$$

8.2 REFLECTION OF LIGHT

Reflection of light is the bouncing of light from a surface. The light ray that hits the surface is called incident ray. The light ray reflected from the surface is called the reflected ray. The line perpendicular to the surface at the point of impact is called the normal line. The angle formed between the incident ray and the normal line is called the angle of incidence. The angle formed between the reflected ray and the normal line is called the angle of reflection. The **law of reflection** states that the angle of incidence (θ_i) and the angle of reflection (θ_r) are equal.

$$\theta_i = \theta_r$$

Example: A light ray is incident on a flat mirror. The angle formed between the surface of the mirror and the incident ray is 25° . Calculate the angle of reflection.

Solution: Since the angle of incidence is angle formed with the normal and the incident ray makes an angle of 25° with the surface, the angle of incidence is $90^\circ - 25^\circ = 65^\circ$.

$$\theta_i = 65^\circ; \theta_r = ?$$

$$\theta_r = \theta_i = 65^\circ$$

Example: Two mirrors are connected at an angle of 120° . A light ray is incident on one of the mirrors at an angle of incidence of 70° . Calculate its angle of reflection on the second mirror.

Solution: Since the angle of incidence on the first mirror is 70° , the angle of reflection on the first mirror is 70° . The angle formed between the surface of the first mirror and the reflected ray is $90^\circ - 70^\circ = 20^\circ$. The reflected ray will continue to hit the second mirror and reflected. The two surfaces of the mirror and the path of the light ray from the first to the second mirror form a triangle. The angle formed between the second mirror and the light ray incident on the second mirror is $180^\circ - (120^\circ + 20^\circ) = 40^\circ$. The angle of incidence on the second mirror is $90^\circ - 40^\circ = 50^\circ$. Therefore the angle of reflection on the second mirror is 50° .

8.3 REFRACTION

Refraction is the bending of light as light crosses the boundary between two mediums. The light ray incident on the boundary is called incident ray. The ray past the boundary is called the refracted ray. The line that is perpendicular to the boundary at the point of impact is called the normal line. The angle formed between the incident ray and the normal line is called the angle of incidence. The angle formed between the refracted ray and the normal line is called the angle of refraction.

As light enters a medium from a vacuum (or approximately air), the speed and the wavelength of the light decrease while the frequency remains the same. The ratio between the speed of light (c) in vacuum and the speed of light (v) in a medium is called the *refractive index* (n) of the medium.

$$n = c/v$$

Refractive index is unit-less. From this definition of refractive index, it is clear that the refractive index (n_a) of vacuum (air) is one and the refractive index of any other medium is greater than one. The refractive index of water (n_w) and glass (n_g) are $4/3$ and $3/2$ respectively. If the wavelength of light is λ_v in vacuum and λ_m in a medium, since frequency remains the same $n = c/v = f\lambda_v / (f\lambda_m)$ and

$$n = \lambda_v / \lambda_m$$

Example: Calculate the speed of light in glass.

Solution: $n_g = 1.5$; $v_g = ?$

$$v_g = c/n_g = 3e8/1.5 \text{ m/s} = 2e8 \text{ m/s}$$

Example: The wavelength of violet light in vacuum is 400 nm. Calculate its wavelength in water.

Solution: $\lambda_v = 400 \text{ nm} = 4e-7 \text{ m}$; $n_w = 4/3$; $\lambda_w = ?$

$$\lambda_w = \lambda_v/n_w = 4e-7/(4/3) \text{ m} = 3e-7 \text{ m}$$

YOUR WORK AT TOMTOM WILL
BE TOUCHED BY MILLIONS.
AROUND THE WORLD. EVERYDAY.

Join us now on www.TomTom.jobs

follow us on **LinkedIn**



#ACHIEVEMORE

TOMTOM 

Snell's law (law of refraction) states that the ratio between the sine of the angle of incidence and the sine of the angle of refraction is equal to the ratio between the speeds of light in the respective mediums. If light enters medium 2 from medium 1 at an angle of incidence θ_1 and the angle of refraction in medium 2 is θ_2 , then $\sin(\theta_1)/\sin(\theta_2) = v_1/v_2 = (c/n_1)/(c/n_2) = n_2/n_1$. Therefore, Snell's can be mathematically expresses as

$$n_1 \sin(\theta_1) = n_2 \sin(\theta_2)$$

It can be easily deduced from this equation that light bends towards the normal as it enters an optically denser (higher refractive index) medium and bends away from the normal as it enters an optically less dense medium. A light ray perpendicular to the boundary passes straight unbent.

Example: A light ray enters water (from air) at an angle of incidence 56° . Calculate the angle of refraction in water.

Solution: $n_a = 1$; $n_w = 4/3$; $\theta_a = 56^\circ$; $\theta_w = ?$

$$n_a \sin(\theta_a) = n_w \sin(\theta_w)$$

$$\sin(\theta_w) = n_a \sin(\theta_a) / n_w = 1 * \sin(56^\circ) / (4/3) = 0.62$$

$$\theta_w = \arcsin(0.62) = 38.3^\circ$$

Example: A light ray enters water (from air) on glass at an angle of incidence of 65° . Calculate the refraction angle in glass (The air-water boundary and the water-glass boundary are parallel).

Solution: First the angle of refraction in water should be calculated from the air-water boundary. The angle of refraction in water and the angle of incidence on the water-glass boundary are equal because they are alternate interior angles. Then the angle of refraction in glass can be obtained from the water-glass boundary.

$$n_a = 1; n_w = 4/3; n_g = 1.5; \theta_a = 65^\circ; \theta_g = ?$$

$$n_a \sin(\theta_a) = n_w \sin(\theta_w)$$

$$\sin(\theta_w) = n_a \sin(\theta_a) / n_w = 1 * \sin(65^\circ) / (4/3) = 0.7$$

$$\theta_w = \arcsin(0.7) = 44.4^\circ$$

$$n_w \sin(\theta_w) = n_g \sin(\theta_g)$$

$$\sin(\theta_g) = n_w \sin(\theta_w) / n_g = (4/3) * \sin(44.4^\circ) / (1.5) = 0.5$$

$$\theta_g = \arcsin(0.5) = 30^\circ$$

8.4 PRACTICE QUIZ 8.1

Choose the best answer. Answers can be found at the back of the book.

1. The scientist who first stated that light is made up of corpuscles is
 - A. Huygens
 - B. Hertz
 - C. Newton
 - D. Planck
 - E. Maxwell
2. Which of the following is a correct statement?
 - A. The electric and magnetic fields of an electromagnetic wave are parallel to the direction of propagation of energy.
 - B. For electromagnetic waves, the physical quantities that vary as a function of position and time are electric and magnetic fields.
 - C. Different electromagnetic waves have different speeds in vacuum.
 - D. According to the current understanding of light, light is a wave.
 - E. The electric and magnetic fields of an electromagnetic wave are parallel to each other.

3. Which of the following is a correct statement?
- A. As light enters a denser medium, its wavelength increases.
 - B. As light enters an optically less dense medium, it bends towards the normal.
 - C. Refractive index of any medium is less or equal to one.
 - D. As light enters a denser medium its frequency remains the same.
 - E. As light enters an optically denser medium, its speed increases
4. Which of the following is a correct statement?
- A. Refractive index of a medium is equal to the ratio of the wavelength of light in vacuum to the wavelength of the light in the medium.
 - B. Refraction is the bending of light as light hits an obstacle.
 - C. Refractive index of a medium is equal to the ratio of the speed of light in the medium to the speed of light in vacuum.
 - D. Angle of reflection may or may not be equal to angle of incidence.
 - E. As light enters medium 2 from medium 1, the ratio of the sine of the angle of incidence in medium 1 to the refractive index of medium 1 is equal to the ratio of the sine of the angle of refraction in medium 2 to the refractive index of medium 2.



Brain power

By 2020, wind could provide one-tenth of our planet's electricity needs. Already today, SKF's innovative know-how is crucial to running a large proportion of the world's wind turbines.

Up to 25 % of the generating costs relate to maintenance. These can be reduced dramatically thanks to our systems for on-line condition monitoring and automatic lubrication. We help make it more economical to create cleaner, cheaper energy out of thin air.

By sharing our experience, expertise, and creativity, industries can boost performance beyond expectations. Therefore we need the best employees who can meet this challenge!

The Power of Knowledge Engineering

Plug into The Power of Knowledge Engineering.
Visit us at www.skf.com/knowledge

SKF

5. One photon of a certain light has an energy of $3.8e-19$ J. Calculate the wavelength of the light.
- A. $364.737e-9$ m
 - B. $312.632e-9$ m
 - C. $573.158e-9$ m
 - D. $521.053e-9$ m
 - E. $416.842e-9$ m
6. Calculate the energy of 100 photons of light of wavelength $6.1e-7$ m.
- A. $45.443e-18$ J
 - B. $32.459e-18$ J
 - C. $35.705e-18$ J
 - D. $22.721e-18$ J
 - E. $38.951e-18$ J
7. Two mirrors are connected so that the angle formed between them is 105° . A light ray is incident on one of the mirrors making an angle of 14° with the surface of the mirror in such a way that the reflected ray is incident on the second mirror. Calculate the angle formed between the light ray reflected from the second mirror and the surface of the second mirror.
- A. 61°
 - B. 56°
 - C. 58°
 - D. 60°
 - E. 63°
8. Two mirrors are joined at an angle. A light ray incident on one of the mirrors making an angle of 29° with the surface of the mirror is reflected from the second mirror making an angle of 40° with the surface of the mirror. Calculate the angle formed between the two mirrors.
- A. 113°
 - B. 111°
 - C. 115°
 - D. 108°
 - E. 110°

9. The speed of light in a certain medium is $2.1e8$ m/s. Calculate the refractive index of the medium.
- A. 1.571
 - B. 1.714
 - C. 2
 - D. 1.429
 - E. 1.857
10. A certain light has a wavelength of $4.9e-7$ m in vacuum. Calculate its wavelength in a medium whose refractive index is 1.63 .
- A. $4.209e-7$ m
 - B. $3.307e-7$ m
 - C. $3.607e-7$ m
 - D. $3.006e-7$ m
 - E. $3.908e-7$ m
11. A light ray enters glass from air at an angle of incidence of 50° . Calculate the angle of refraction in glass. Refractive index of water is 1.5 .
- A. 30.71°
 - B. 36.852°
 - C. 39.923°
 - D. 33.781°
 - E. 18.426°
12. Light enters a certain medium from air at an angle of incidence of 50° . If the angle of refraction in the medium is 35° , calculate the refractive index of the medium.
- A. 1.469
 - B. 1.336
 - C. 0.801
 - D. 1.068
 - E. 1.736

13. Light enters a certain medium from air at an angle of incidence of 20° . If the speed of light in the medium is $2.7e8$ m/s, calculate the angle of refraction in the medium.
- A. 17.928°
 - B. 16.135°
 - C. 23.306°
 - D. 10.757°
 - E. 21.513°
14. Water is placed on top of glass. A light ray enters the water from air at an angle of incidence of 55° . Calculate the angle of refraction in glass. Refractive index of water and glass are $4/3$ and 1.5 respectively.
- A. 43.03°
 - B. 33.1°
 - C. 29.79°
 - D. 26.48°
 - E. 19.86°



> Apply now

REDEFINE YOUR FUTURE
**AXA GLOBAL GRADUATE
PROGRAM 2015**

redefining / standards 

agence.cdg - © Photonostop

8.5 DISPERSION OF LIGHT

Dispersion is the separation of white light into different colors as light enters a medium from air. White light is composed of seven different colors. Arranged in increasing order of wavelength, these are violet, indigo, blue, green, yellow, orange and red (Abbreviated as VIBGYOR). Violet has the shortest wavelength and red has the longest wavelength. The reason white separates into its component colors as light enters a medium is because the refractive index of a medium depends on the wavelength of the light. The refractive index increases as the wavelength decreases. That is, violet has the largest refractive index and red has the smallest refractive index. According to Snell's law, the greater the refractive index the smaller the angle of refraction or the greater the deviation angle from the path of the incident light. Thus, as light enters a medium from air, violet light will be bent by the largest angle and red light will be bent by the smallest angle.

A good example of dispersion is the rainbow. Rainbow happens because the cloud has different refractive indexes for the different colors of light.

Example: White light enters glass (from air) at an angle of incidence of 65° . The refractive indices of the glass for violet and red light are respectively 1.52 and 1.48 . Calculate the angle formed between red light and violet light after refraction.

Solution: $\theta_a = 65^\circ$; $n_a = 1$; $n_{gr} = 1.48$; $n_{gv} = 1.52$; $\theta = \theta_{gr} - \theta_{gv} = ?$

$$n_{nr} \sin(\theta_{gr}) = n_a \sin(\theta_a)$$

$$\sin(\theta_{gr}) = n_a \sin(\theta_a) / n_{gr} = 1 * \sin(65^\circ) / 1.48 = 0.612$$

$$\theta_{gr} = \arcsin(0.612) = 37.8^\circ$$

$$n_{nv} \sin(\theta_{gv}) = n_a \sin(\theta_a)$$

$$\sin(\theta_{gv}) = n_a \sin(\theta_a) / n_{gv} = 1 * \sin(65^\circ) / 1.52 = 0.596$$

$$\theta_{gv} = \arcsin(0.596) = 36.6^\circ$$

$$\theta = \theta_{gr} - \theta_{gv} = 37.8^\circ - 36.6^\circ = 1.2^\circ$$

8.6 TOTAL INTERNAL REFLECTION

As light enters an optically less dense medium, it bends away from the normal. As the angle of incidence in the denser medium is increased, for a certain angle the angle of refraction will be 90° ; that is, the light ray will be refracted parallel to the boundary. The angle of incidence in the denser medium for which the angle of refraction is 90° is called the *critical angle* (θ_c) of the boundary. If the refractive indexes of the less dense and more dense medium are $n_<$ and $n_>$ respectively, then $n_> \sin(\theta_c) = n_< \sin(90^\circ) = n_<$; and the critical angle of the boundary is given as follows.

$$\theta_c = \arcsin(n_</n_>)$$

For angles of incidence less than the critical angle, both reflection and refraction take place. The fact that we can see our face in water indicates that some of the light rays are reflected; and the fact that we can see objects inside water indicates that some of the light rays are refracted. But for angles greater than the critical angle, only reflection takes place. *Total internal reflection* is a phenomenon where only reflection takes place at the boundary between two mediums and occurs only when light enters a less dense medium at an angle of incidence greater than the critical angle.

Example: Calculate the critical angle for the boundary formed between

- a) air and water.

Solution: $n_< = n_a = 1$; $n_> = n_w = 4/3$; $\theta_c = ?$

$$\theta_c = \arcsin(n_</n_>) = 48.6^\circ$$

-
- b) water and glass.

Solution: $n_< = n_w = 4/3$; $n_> = n_g = 1.5$; $\theta_c = ?$

$$\theta_c = \arcsin(n_</n_>) = 62.8^\circ$$

Example: A light source is placed in water at a depth of 0.5 m. Calculate the radius of a circular region at the surface of the water from which light rays come out.

Solution: Light rays from the light source will hit the air-water boundary at different angles of incidence. Only the light rays whose angle of incidence is less than the critical angle can be refracted into air. The light rays whose angle of incidence is greater than the critical angle will be reflected back because total internal reflection takes place. Because of this, light rays will come out of a certain circular region of the surface only. The angle of incidence for the light rays that fall on the boundary of this circular region is equal to the critical angle of the boundary. The radius can be calculated from the right angled triangle formed by a line connecting the source with the center of the circle (a), the line that connects the center of the circle to a point on the boundary of the circular region (r) and the line connecting the source to the point on the boundary. The first two lines are perpendicular to each other and the angle formed between the last two lines is the critical angle. Thus $\theta_c = \arctan (r/a)$.

LIGS University based in Hawaii, USA

is currently enrolling in the
Interactive Online **BBA, MBA, MSc,**
DBA and PhD programs:

- ▶ enroll **by October 31st, 2014** and
- ▶ **save up to 11%** on the tuition!
- ▶ pay in 10 installments / 2 years
- ▶ Interactive **Online education**
- ▶ visit www.ligsuniversity.com to
find out more!

Note: LIGS University is not accredited by any
nationally recognized accrediting agency listed
by the US Secretary of Education.
More info [here](#).



$$n_{<} = n_a = 1; n_{>} = n_w = 4/3; a = 0.5 \text{ m}; r = ?$$

$$\theta_c = \arcsin (n_{<} / n_{>}) = \arcsin (1 / (4/3)) = 48.6^\circ$$

$$\tan (\theta_c) = r / a$$

$$r = a \tan (\theta_c) = 0.5 * \tan (48.6^\circ) = 0.57 \text{ m}$$

Example A light ray is incident on one of the legs of a 45° right angled glass prism perpendicularly. Trace the path of the light ray.

Solution: Since the light ray is perpendicular to the surface (angle of incidence zero), it will enter undeflected. Then it will be incident on the glass-air boundary on the larger face (hypotenuse). Since it is a 45° prism, from simple geometry, it can be shown that the angle of incidence on this boundary is 45° . Since the light ray is incident on the denser medium (glass), what happens depends on the critical angle of the boundary. If the critical angle is greater than 45° it can be refracted. But if the critical angle is less than 45° , total internal reflection will take place and the light ray will be incident on the other leg of the prism perpendicularly (as can be shown by simple geometry) and will be refracted to air undeflected.

$$n_{<} = n_a = 1; n_{>} = n_g = 1.5; \theta_c = ?$$

$$\theta_c = \arcsin (n_{<} / n_{>}) = \arcsin (1 / 1.5) = 41.8^\circ$$

Since the critical angle is less than the angle of incidence at the hypotenuse, total internal reflection takes place and the light ray is incident on the other leg perpendicularly and is reflected to air undeflected.

8.7 PRACTICE QUIZ 8.2

Choose the best answer. Answers can be found at the back of the book.

- Which of the following is a correct statement?
 - Dispersion is the separation of white light into different colors as light enters a medium from vacuum (air).
 - All colors of light have the same refractive index in a given medium.
 - As wavelength of light increases, refractive index increases.
 - The seven different colors of light listed in decreasing order of wavelength are violet, indigo, blue, green, yellow, orange and red.
 - Dispersion occurs because different colors of light have different speeds in vacuum.
- The color of light with the smallest refractive index is
 - violet
 - red
 - green
 - yellow
 - blue
- Which of the following is a correct statement?
 - When light enters a less dense medium at an angle of incidence greater than the critical angle, both reflection and refraction take place.
 - When light enters a less dense medium both reflection and refraction take place for all angles of incidence.
 - When light enters a denser medium, both reflection and refraction takes place.
 - Total internal reflection cannot occur when light enters a less dense medium.
 - When light enters a less dense medium at an angle of incidence less than the critical angle, only refraction takes place.
- Calculate the critical angle for the boundary between two mediums of refractive indexes 2.1 and 1.2 .
 - 31.365°
 - 34.85°
 - 20.91°
 - 41.82°
 - 24.395°

5. When light enters a medium of refractive index 1.3 from a medium of refractive index 2 , for which of the following angle of incidence would both reflection and refraction take place?
- A. 42.674°
 - B. 43.665°
 - C. 37.019°
 - D. 44.776°
 - E. 41.977°
6. A source of light is placed 0.6 m below the surface of water in a pond. Because of total internal reflection, light come out of the surface only from a certain circular region. Calculate the radius of this circular region. (Refractive index of water is $4/3$).
- A. 0.884 m
 - B. 0.816 m
 - C. 0.68 m
 - D. 0.408 m
 - E. 0.612 m

TURN TO THE EXPERTS FOR **SUBSCRIPTION** CONSULTANCY

Subscribe is one of the leading companies in Europe when it comes to innovation and business development within subscription businesses.

We innovate new subscription business models or improve existing ones. We do business reviews of existing subscription businesses and we develop acquisition and retention strategies.

Learn more at [linkedin.com/company/subscribe](https://www.linkedin.com/company/subscribe) or contact Managing Director Morten Suhr Hansen at mha@subscribe.dk

SUBSCR✓**BE** - to the future

7. The refractive indexes of red light and violet light in a certain glass are 1.48 and 1.52 respectively. If white light enters this glass from air at angle of incidence of 50° , the angle of refractions for violet and red light respectively are
- A. $30.263^\circ, 37.405^\circ$
 - B. $30.263^\circ, 31.171^\circ$
 - C. $18.158^\circ, 40.523^\circ$
 - D. $24.211^\circ, 37.405^\circ$
 - E. $24.211^\circ, 31.171^\circ$
8. The refractive indexes of red light and violet light in a certain glass are 1.48 and 1.52 respectively. If white light enters this glass from air at angle of incidence of 30° , the angle formed between the violet light and red light after refraction is
- A. 0.594°
 - B. 0.54°
 - C. 0.756°
 - D. 0.432°
 - E. 0.702°

9 MIRRORS AND LENSES

Your goals for this chapter are to learn about the properties of the images formed by mirrors and lenses.

An image of a point formed by a mirror is the point at which light rays from the point converge or seem to converge after reflection. An image of a point formed by a lens (a piece of glass with spherical surfaces) is the point at which light rays from the point converge or seem to converge after refraction. There are two kinds of images: real and virtual. A *real image* is an image where actual light rays converge. A real image can be captured in a screen. An example is an image formed by a cinema projector. A *virtual image* is an image where actual light rays do not converge but seem to converge. A virtual image cannot be captured in a screen. An example is an image formed by a flat mirror.

9.1 MIRRORS

9.1.1 FLAT MIRRORS

The following diagram shows image formation by a flat mirror.

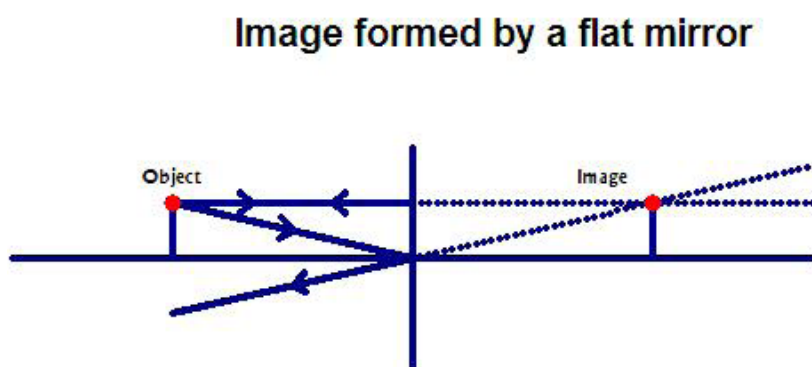

Figure 9.1

The image formed by a flat mirror has the following properties.

1. It is a virtual image.
2. It is located behind the mirror.
3. It has the same size as the object. Its perpendicular distance from the mirror is equal to the perpendicular distance of the object from the mirror.
4. It is erect (not inverted) in a direction parallel to the mirror.
5. It is laterally inverted. In other words the image is inverted in a direction perpendicular to the mirror. For example the image of an arrow pointing towards the mirror is an arrow pointing towards the arrow itself.

9.1.2 CONCAVE MIRROR

A concave mirror is a spherical mirror with the reflecting surface being the inner surface. The following diagram shows a concave mirror.

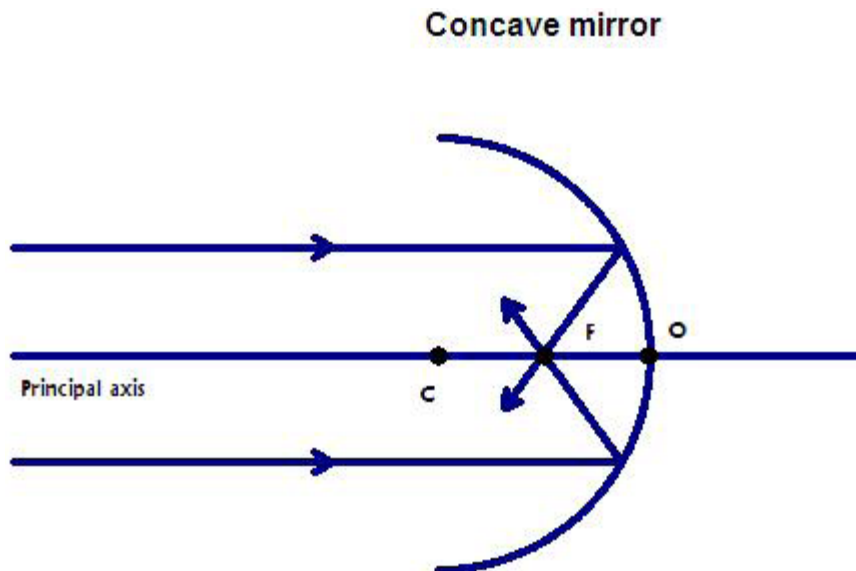

Figure 9.2

"I studied English for 16 years but...
...I finally learned to speak it in just six lessons"
Jane, Chinese architect

ENGLISH OUT THERE

Click to hear me talking before and after my unique course download

The advertisement features a woman with dark hair and sunglasses on her head, smiling. To her right is a green speech bubble containing the text 'ENGLISH OUT THERE'. Below the woman is a call to action: 'Click to hear me talking before and after my unique course download'. The background is a blurred image of a classroom or office.

The center of the spherical surface is called the *center of curvature* (point C in the diagram) of the mirror. The midpoint of the mirror is called the *center of the mirror* (point O in the diagram). The line joining the center of curvature and the center of the mirror is called the *principal axis* of the mirror. The point at which light rays parallel to the principal axis converge after reflection is called the *focus* (point F in the diagram) of the mirror. The focus of a concave mirror is real because actual light rays meet at the point. The focus is located midway between the center of curvature and the center of the mirror. The distance between the focus and the center of the mirror is called the *focal length* (f) of the mirror.

Only two light rays originating from a point are needed to construct its image. The image is the point at which these light rays converge or seem to converge after reflection. There are 3 special light rays that can be used when constructing an image.

1. A light ray parallel to the principal axis is reflected through the focus.
2. A light ray through the focus is reflected parallel to the principal axis.
3. A light ray through the center of curvature returns in its own path.

The following diagram shows the construction of the image formed by a concave mirror when the object is placed beyond the center of curvature.

Image formed by a concave mirror when the object is placed beyond the center of curvature.

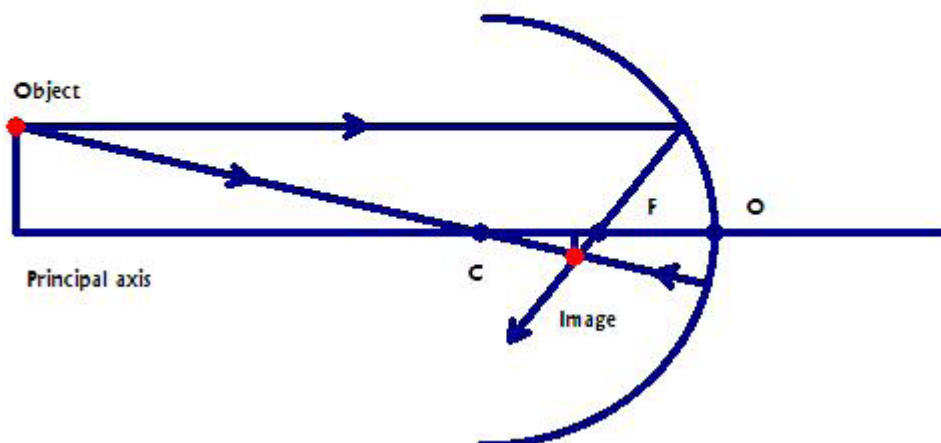

Figure 9.3

The image formed by a concave mirror when the object is located beyond the center of curvature has the following properties.

1. The image is real.
2. The image is inverted.
3. The image is diminished.
4. The image is located between the focus and the center of curvature on the same side as the object.

The following diagram shows the construction of the image formed by a concave mirror when the object is located between the center of curvature and the focal point.

**Image formed by a concave mirror when the object
between the center of curvature and the focal point.**

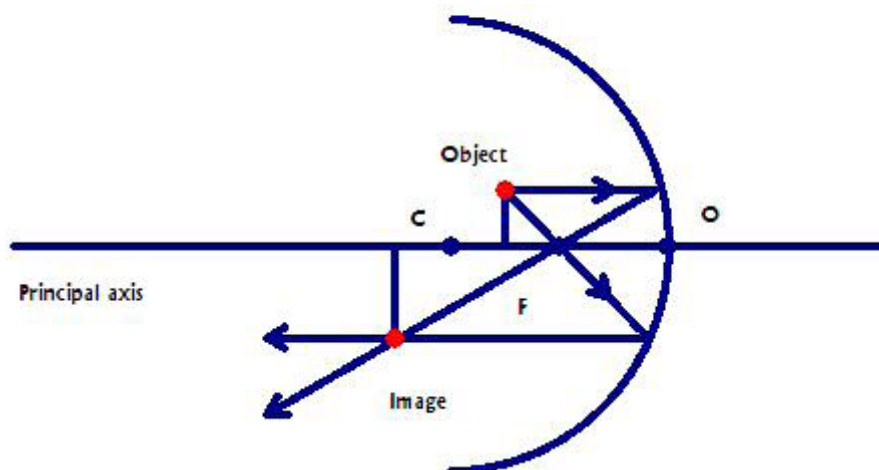

Figure 9.4

An image formed by a concave mirror when the object is placed between the center of curvature and the focus has the following properties.

1. The image is real.
2. The image is inverted.
3. The image is enlarged.
4. The image is located beyond the center of curvature on the same side as the object.

The following diagram shows the image construction of the image formed by a concave mirror when the object is located between the focus and the center of the mirror.

Image formed by a concave mirror when the object is placed between the focal point and the center of the mirror.

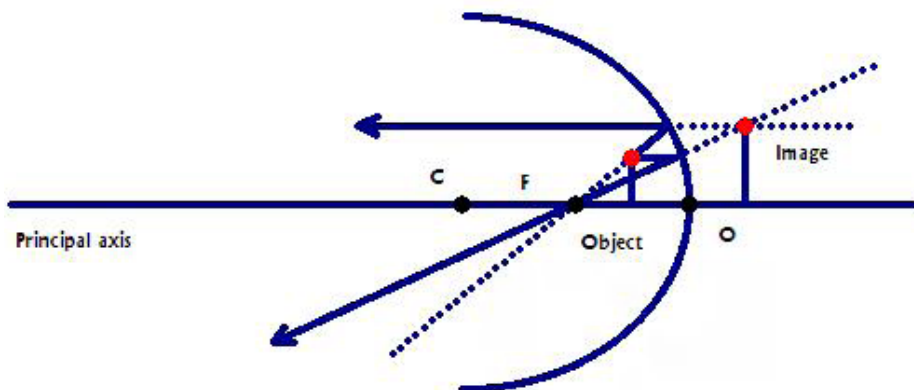





Figure 9.5



How to retain your top staff
FIND OUT NOW FOR FREE

DO YOU WANT TO KNOW:

-  What your staff really want?
-  The top issues troubling them?
-  How to make staff assessments work for you & them, painlessly?

Get your free trial
Because happy staff get more done

The image formed by a concave mirror when the object is placed between the focus and the center of the mirror has the following properties.

1. The image is virtual.
2. The image is erect.
3. The image is enlarged.
4. The image is located behind the mirror.

9.1.3 CONVEX MIRROR

A *convex mirror* is a spherical mirror with the outside surface being the reflecting surface. The following diagram shows a convex mirror.

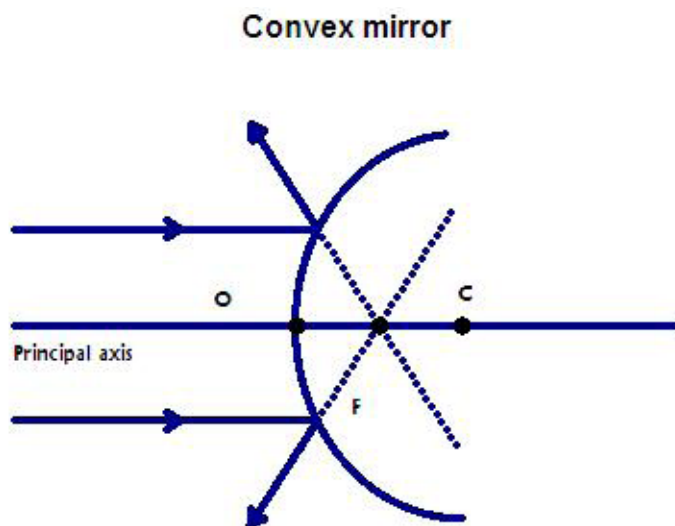

Figure 9.6

The center of the spherical surface is called the *center of curvature* (point C on the diagram) of the mirror. The mid-point of the mirror is called the *center of the mirror* (point O on the diagram). The line joining the center of curvature and the center of the mirror is called the *principal axis* of the mirror. The point from which light rays parallel to the principal axis seem to come from after reflection is called the *focus* (point F on the diagram) of the mirror. The focus of a convex mirror is virtual because actual light rays do not meet at the focus. The focus is located midway between the center of curvature and the center of the mirror. The distance between the focus and the center of the mirror is called the *focal length* (f) of the mirror.

There are 3 special light rays that can be used in constructing images formed by a convex mirror.

1. A light ray parallel to the principal axis seems to come from the focus after reflection.
2. A light ray directed towards the focus is reflected back parallel to the principal axis.
3. A light ray directed towards the center of curvature is reflected in its own path.

The following diagram shows the image construction of the image formed by a convex mirror.

Image formed by a convex mirror

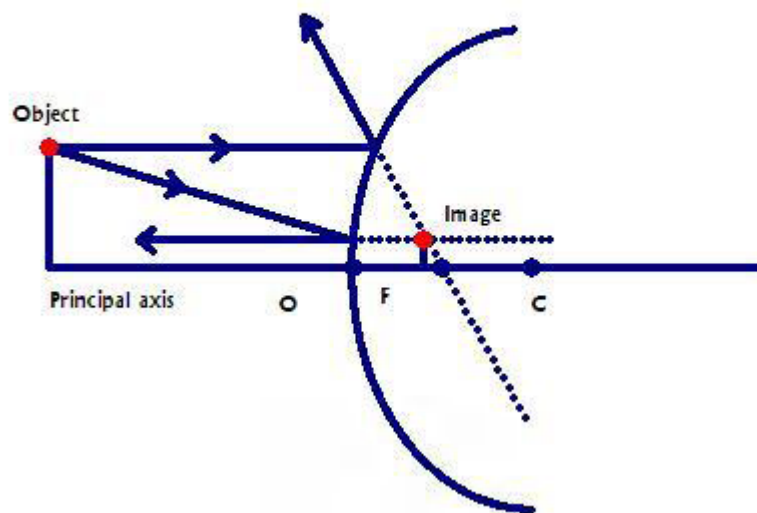

Figure 9.7

The image formed by a convex mirror has the following properties.

1. The image is virtual.
2. The image is erect.
3. The image is diminished.
4. The image is located behind the mirror.

9.1.4 THE MIRROR EQUATION

The mirror equation is an equation that relates the distance of the object from the center of the mirror, the distance of the image from the center of the mirror and the focal length (distance between focus and the center of the mirror). The distance between the object and the center of the mirror is called *object distance* (p). It is taken to be positive if the object is real and negative if the object is virtual. A virtual object is possible when more than one mirrors are involved. The distance between the image and the center of the mirror is called the *image distance* (q). The image distance is taken to be positive if the image is real and negative if the image is virtual. The focal length (f) is taken to be positive if the focus is real and negative if the focus is virtual. Thus, the focal length of a concave mirror is positive since its focus is real and that of a convex mirror is negative because its focus is virtual. The focal length of a mirror is half the radius of curvature: $|f| = R/2$ where R is the radius of curvature of the mirror. The following equation is the mirror equation.

$$1/f = 1/p + 1/q$$

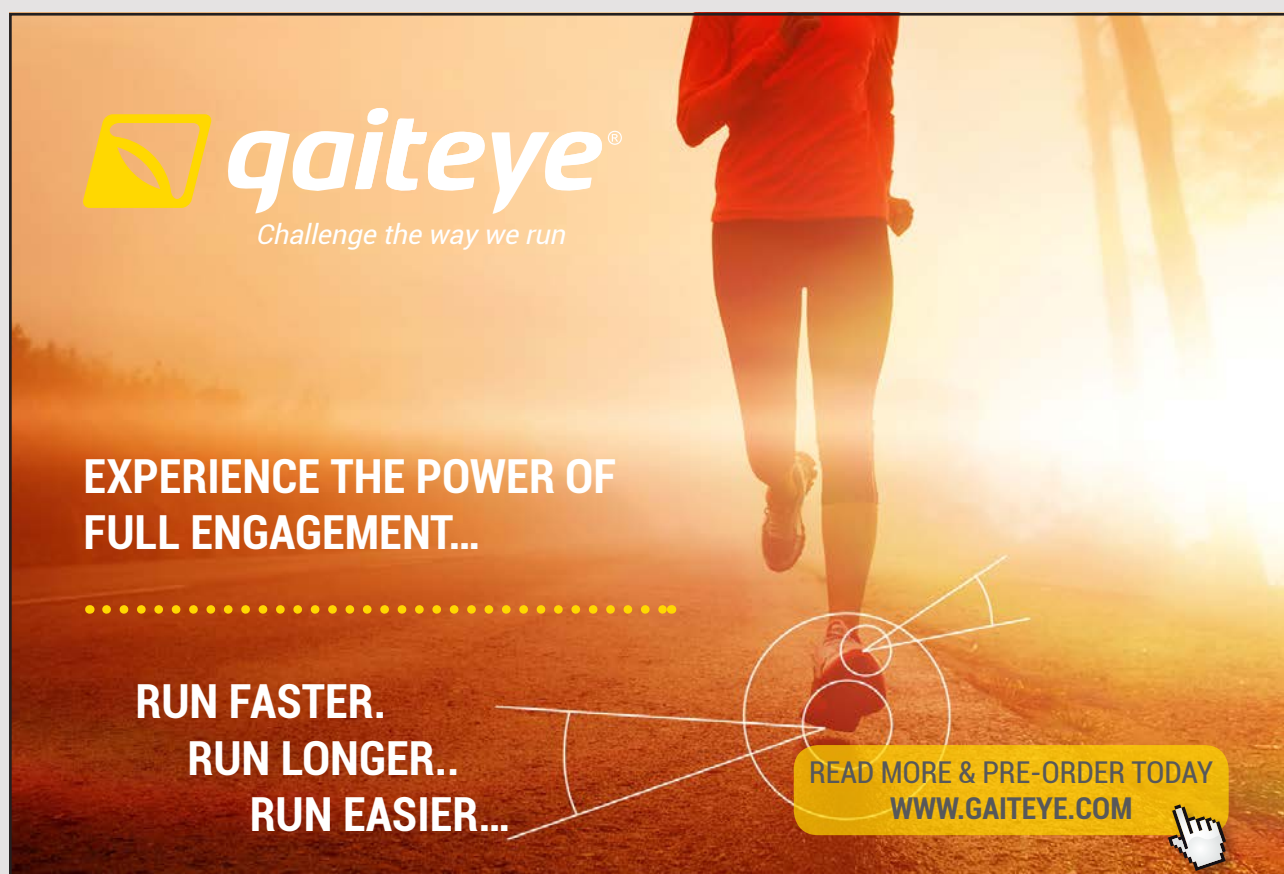

gaiteye[®]
Challenge the way we run

**EXPERIENCE THE POWER OF
FULL ENGAGEMENT...**

.....

**RUN FASTER.
RUN LONGER..
RUN EASIER...**

READ MORE & PRE-ORDER TODAY
WWW.GAITEYE.COM

The *magnification* (M) of a mirror is defined to be the ratio between the size of the image (h_i) and the size of the object (h_o). The size of the object (image) is taken to be positive if the object (image) is erect and negative if the object (image) is inverted.

$$M = h_i/h_o$$

It can also be shown that the magnification is equal to the negative of the ratio between image distance and object distance.

$$M = -q/p$$

Example: An object of height 0.02 m is placed 0.4 m in front of a concave mirror whose radius of curvature is 0.1 m.

- a) Determine its focal length.

Solution: The focal length of a concave mirror is positive.

$$R = 0.1 \text{ m}; f = ?$$

$$|f| = R/2 = 0.1/2 \text{ m} = 0.05 \text{ m}$$

$$f = 0.05 \text{ m}$$

- b) Calculate the distance of the image from the mirror.

Solution: $p = 0.4$ m; $q = ?$

$$1/f = 1/p + 1/q$$

$$1/q = 1/f - 1/p = (1/0.05 - 1/0.4) \text{ 1/m} = 17.5 \text{ 1/m}$$

$$q = 1/17.5 \text{ m} = 0.06 \text{ m}$$

- c) Is the image real or virtual?

Solution: The image is real because the image distance is positive.

d) Calculate the magnification.

Solution: $M = ?$

$$M = -q/p = -0.06/0.4 = -0.15$$

e) Calculate the size of the image.

Solution: $h_o = 0.02$ m; $h_i = ?$

$$M = h_i/h_o$$

$$h_i = Mh_o = -0.15 * 0.02 \text{ m} = -0.003 \text{ m}$$

f) Is the image erect or inverted?

Solution: The image is inverted because h_i is negative.

9.2 PRACTICE QUIZ 9.1

Choose the best answer. Answers can be found at the back of the book.

- Which of the following is a correct statement?
 - The image formed by a flat mirror is real.
 - The image formed by a flat mirror has the same size as the object.
 - The image formed by a flat mirror is inverted in a direction parallel to the mirror.
 - For an image formed by a flat mirror, the perpendicular distance between the image and mirror is less than the perpendicular distance between the object and the mirror.
 - The image formed by a flat mirror is not inverted in a direction perpendicular to the mirror.

2. Which of the following is a correct statement?
- A. The focal point of a convex mirror is the point from which light rays parallel to the principal axis seem to come from after reflection.
 - B. The center of curvature of a concave mirror is located midway between the focal point and the center of the mirror.
 - C. The focal point of a concave mirror is the point from which light rays parallel to the principal axis seem to come from after reflection.
 - D. The focal point of a concave mirror is virtual.
 - E. The focal point of a convex mirror is real.
3. Which of the following is a correct statement about a concave mirror?
- A. All of the other choices are not correct.
 - B. A light ray parallel to the principal axis is reflected back through the center of curvature.
 - C. A light ray through the center of curvature of the mirror returns in its own path after reflection.
 - D. A light ray through the focal point returns in its own path.
 - E. A light ray directed to the center of the mirror returns in its own path.

This e-book
is made with
SetaPDF

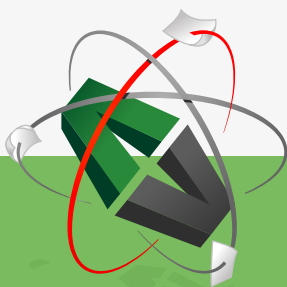

PDF components for PHP developers

www.setasign.com



4. Which of the following is true about a convex mirror.
 - A. A light ray directed the center of the mirror is reflected in its own path.
 - B. The focal point of a convex mirror is real.
 - C. A light ray parallel to the principal axis seems to come from the center of curvature after reflection.
 - D. A light ray directed towards the center of curvature is reflected in its own path.
 - E. A light ray directed towards the focal point is reflected in its own path.

5. When an object is placed between the center of curvature and the focal point of a concave mirror
 - A. the image is enlarged.
 - B. the image is erect.
 - C. the image is virtual
 - D. All of the other choices are not correct.
 - E. the image is formed behind the mirror.

6. When an object is placed between a concave mirror and its focal point,
 - A. none of the other choices are correct.
 - B. the image is real.
 - C. the image is formed in front of the mirror.
 - D. the image is inverted.
 - E. the image is enlarged.

7. When an object is placed beyond the center of curvature (at a distance greater than the radius) of a concave mirror,
 - A. none of the other choices are correct.
 - B. the image is formed between the mirror and the focal point.
 - C. the image is real.
 - D. the image is enlarged.
 - E. the image is erect.

8. For an object placed in front of a convex mirror,
 - A. the image is formed in front of the mirror.
 - B. the image may be erect or diminished.
 - C. the image may be real or virtual.
 - D. the image is always real.
 - E. the image is always diminished.

9. An object is placed 0.2 m in front of a concave mirror whose radius of curvature is 0.06 m. Calculate the image distance.
- A. $3.176e-2$ m
 - B. $3.529e-2$ m
 - C. $4.941e-2$ m
 - D. $4.588e-2$ m
 - E. $2.824e-2$ m
10. An object is placed 0.08 m in front of a convex mirror whose radius of curvature is 0.08 m. Calculate the image distance.
- A. $-2.133e-2$ m
 - B. $-3.733e-2$ m
 - C. $-3.467e-2$ m
 - D. $-2.667e-2$ m
 - E. $-2.4e-2$ m
11. An object of height 0.025 m is placed 0.12 m in front of a concave mirror whose radius of curvature is 0.12 m. Calculate the height of the image.
- A. $-1.75e-2$ m
 - B. $-2.5e-2$ m
 - C. $-2e-2$ m
 - D. $-3.5e-2$ m
 - E. $-2.75e-2$ m
12. An object of height 0.04 m is placed 0.16 m in front of a convex mirror whose radius of curvature is 0.06 m. Calculate the height of the image.
- A. $0.632e-2$ m
 - B. $0.379e-2$ m
 - C. $0.442e-2$ m
 - D. $0.505e-2$ m
 - E. $0.695e-2$ m

9.3 LENSES

A *lens* is a piece of glass with spherical surfaces. There are two types of lenses. They are convex (converging) lens and concave (diverging) lens.

9.3.1 CONVEX LENS

The following diagram shows a convex lens.

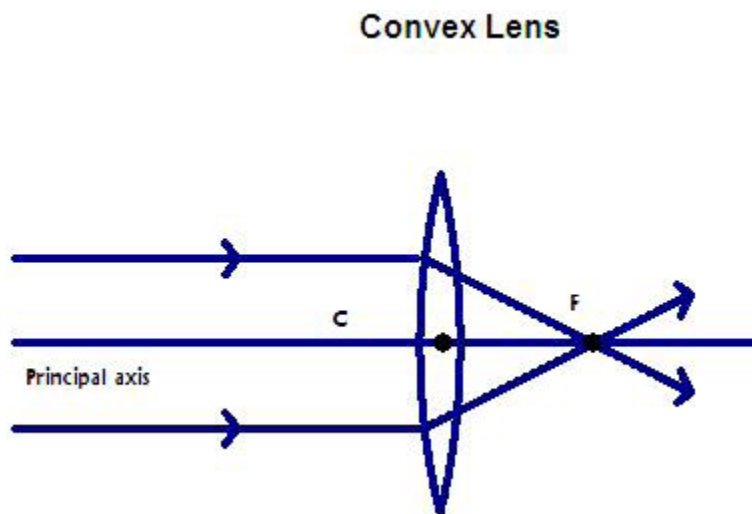

Figure 9.8



Discover the truth at www.deloitte.ca/careers

Deloitte.

© Deloitte & Touche LLP and affiliated entities.

The mid-point of the lens (point C in the diagram) is called the *center of the lens*. The line joining the centers of curvature of both surfaces and the center of the lens is called the *principal axis* of the lens. The point at which light rays parallel to the principal axis converge after refraction is called the *focus* (point F on the diagram) of the lens. The focus of a convex lens is real because actual light rays meet at the point. The distance between the focus and the center of the lens is called the *focal length* of the lens.

There are three special light rays that can be used to construct images formed by a convex lens.

1. A light ray parallel to the principal axis passes through the focal point after refraction.
2. A light ray through the focal point is refracted parallel to the principal axis.
3. A light ray through the center of the lens passes undeflected.

The following diagram shows the image construction of the image formed by a convex lens when the object is placed beyond twice the focal length.

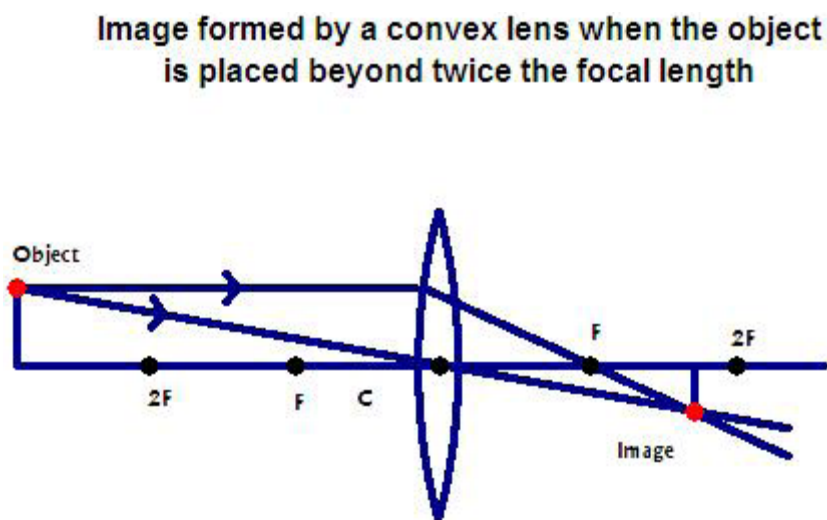

Figure 9.9

The image formed by a convex lens when the object is placed beyond twice the focal length has the following properties.

1. The image is real.
2. The image is inverted.
3. The image is diminished.
4. The image is located at a distance greater than the focal length but smaller than twice the focal length on the other side of the lens.

The following diagram shows the image construction of the image formed by a convex lens when the object is located at a distance greater than the focal length but less than twice the focal length.

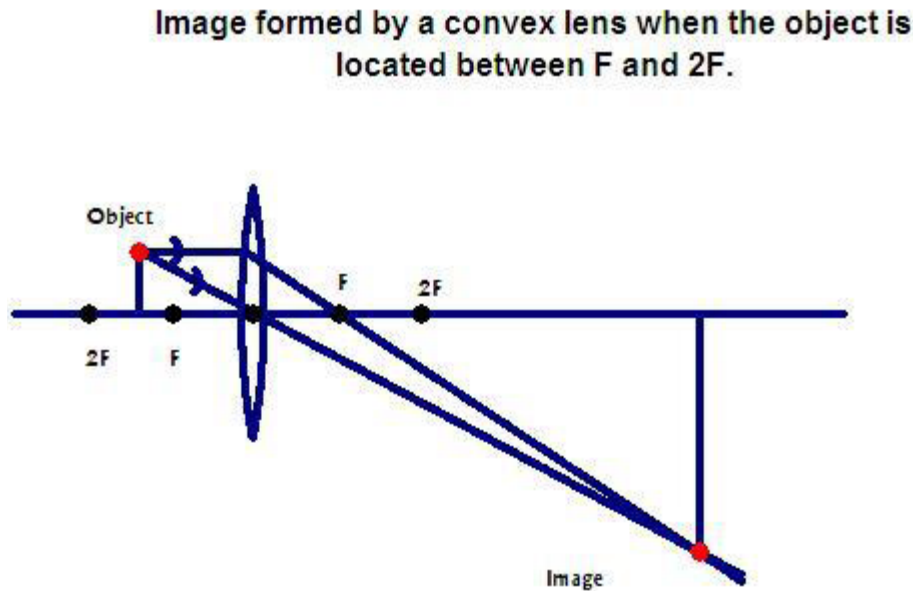

Figure 9.10

The image formed by a convex lens when the object is placed at a distance greater than the focal length but less than twice the focal length has the following properties.

1. The image is real.
2. The image is inverted.
3. The image is enlarged.
4. The image is located beyond twice the focal length on the other side of the lens.

The following diagram shows the image construction of the image formed by a convex lens when the object is placed between the focus and the center of the lens.

Image formed by a convex lens when the object is placed between the lens and the focal point.

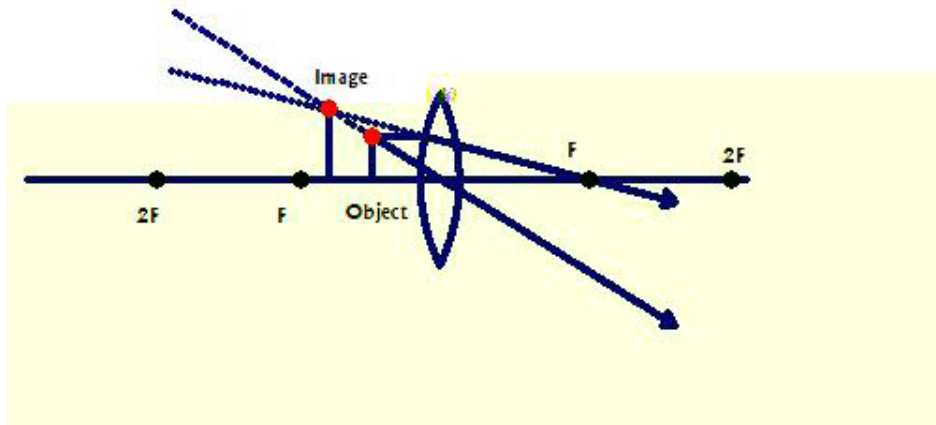

Figure 9.11

© 2013 Accenture. All rights reserved.

be > your degree

Bring your talent and passion to a global organization at the forefront of business, technology and innovation. Discover how great you can be.

Visit accenture.com/bookboon

Be greater than.
consulting | technology | outsourcing

>
accenture
High performance. Delivered.

The image formed by a convex lens when the object is located between the focus and the center of the lens has the following properties.

1. The image is virtual.
2. The image is erect.
3. The image is enlarged.
4. The image is formed on the same side as the object.

9.3.2 CONCAVE LENS

The following diagram shows a concave lens.

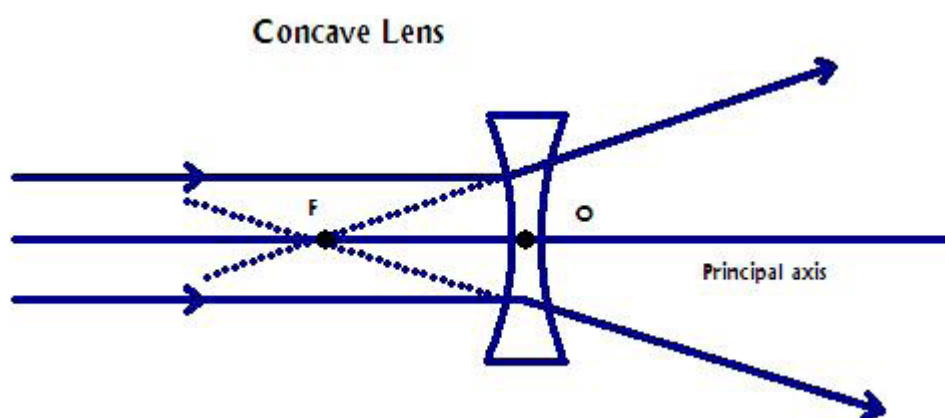

Figure 9.12

The mid-point of the lens (point O in the diagram) is called the *center of the lens*. The line joining the centers of curvature of the surfaces of the lens and the center of the lens is called the *principal axis* of the lens. The point from which light rays parallel to the principal axis seem to come from after refraction is called the *focus* of the lens. The focus of a concave lens is virtual because actual light rays do not meet at the focus. The distance between the focus and the center of the lens is called the *focal length* of the lens.

There are three special light rays used to construct images formed by a concave lens.

1. A light ray parallel to the principal axis seems to come from the focal point after refraction.
2. A light ray directed towards the focal point is refracted parallel to the principal axis.
3. A light ray directed towards the center of the lens passes undeflected.

The following diagram shows the image construction of the image formed by a concave lens.

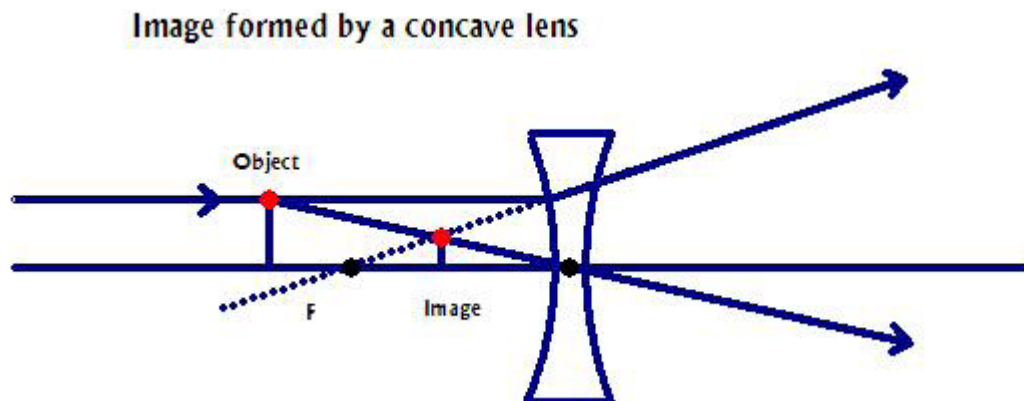
**Figure 9.13**

The image formed by a concave lens has the following properties.

1. The image is virtual.
2. The image is erect.
3. The image is diminished.
4. The image is located on the same side as the object.

9.3.3 THE LENS EQUATION

The lens equation is an equation that relates the object distance, image distance and the focal length. The *object distance* (p) is the distance between the object and the center of the lens. It is taken to be positive if the object is real and negative if the object is virtual. The *image distance* (q) is the distance between the image and the center of the lens. It is taken to be positive if the image is real and negative if the image is virtual. The focal length (f) is the distance between the focal point and the center of the lens. The focal length is taken to be positive if the focus is real and negative if the focus is virtual. This means the focal length of a convex lens is positive (because its focus is real) and that of a concave lens is negative (because its focus is virtual). The following equation is the so called lens equation.

$$1/f = 1/p + 1/q$$

The magnification of a lens is defined to be the ratio between the size of the image (h_i) and the size of the object (h_o). The size of the object (image) is taken to be positive if the object (image) is erect and negative if the object (image) is inverted.

$$M = h_i/h_o$$

The magnification is also equal to the negative of the ratio between the image distance and object distance.

$$M = -q/p$$

Example: An object of height 0.03 m is placed 0.3 m in front of a concave lens whose focal length is 0.06 m.

a) Calculate the distance of the image from the center of the lens.

Solution: The focal length is negative because the lens is concave.

$$f = -0.06 \text{ m}; p = 0.3 \text{ m}; q = ?$$

$$1/q = 1/f - 1/p = (1/(-0.06) - 1/0.3) \text{ m}^{-1} = -20 \text{ m}^{-1}$$

$$q = 1/(-20) \text{ m} = -0.05 \text{ m}$$

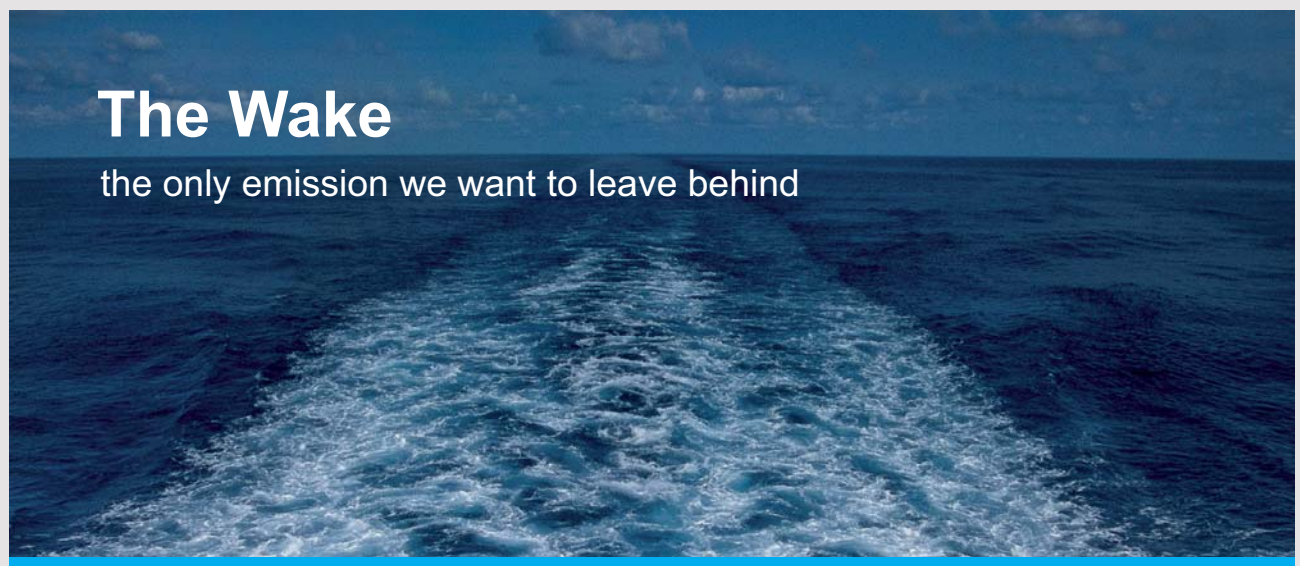

The Wake

the only emission we want to leave behind

Low-speed Engines Medium-speed Engines Turbochargers Propellers Propulsion Packages PrimeServ

The design of eco-friendly marine power and propulsion solutions is crucial for MAN Diesel & Turbo. Power competencies are offered with the world's largest engine programme – having outputs spanning from 450 to 87,220 kW per engine. Get up front! Find out more at www.mandieselturbo.com

Engineering the Future – since 1758.

MAN Diesel & Turbo



b) Is the image real or virtual?

Solution: It is virtual because the image distance is negative.

c) Calculate its magnification.

Solution: $M = ?$

$$M = -q/p = -(-0.05)/0.3 = 0.17$$

d) Calculate the height of the image and determine if the image is erect or inverted.

Solution: $h_o = 0.03$ m; $h_i = ?$

$$M = h_i/h_o$$

$$h_i = Mh_o = 0.17 * 0.03 \text{ m} = 0.0051 \text{ m}$$

The image is erect because h_i is positive.

9.3.4 LENS MAKERS EQUATION

If the radius of curvature of the surface of a lens upon which the light rays are incident is R_1 and the radius of curvature of the other surface is R_2 , then the focal length of the lens is given by

$$1/f = (n - 1) (1/R_1 - 1/R_2)$$

Where n is the refractive index of the lens. A radius of curvature of the surface of a lens is taken to be positive if the direction from the surface towards the center of curvature of the surface is the same as the direction of the incident light rays and negative if opposite to the direction of the incident light rays.

Example: Both surfaces of a convex lens have a radius of curvature of 0.05 m. The refractive index of the glass is 1.5 . Calculate the focal length of the lens.

Solution: The radius of curvature of the surface upon which the light rays are incident (R_1) is positive because the direction from the surface towards its center of curvature is the same as the direction of the incident light rays. The radius of curvature of the other surface is negative because the direction from the surface to its center of curvature is opposite to the direction of the incident light rays.

$$n = 1.5; R_1 = 0.05 \text{ m}; R_2 = -0.05 \text{ m}; f = ?$$

$$1/f = (n - 1) (1/R_1 - 1/R_2) = (1.5 - 1) * (1/0.05 - 1/-0.05) \text{ m}^{-1} = 1/0.05 \text{ m}^{-1}$$

$$f = 0.05 \text{ m}$$

Example: Both surfaces of a concave lens have a radius of curvature of 0.04 m. The refractive index of the glass is 1.5 . Calculate the focal length of the lens.

Solution: The radius of curvature of the surface upon which the light rays are incident (R_1) is negative because the direction from the surface towards its center of curvature is opposite to the direction of the incident light rays. The radius of curvature of the other surface is positive because the direction from the surface to its center of curvature is the same as the direction of the incident light rays.

$$n = 1.5; R_1 = -0.04 \text{ m}; R_2 = 0.05 \text{ m}; f = ?$$

$$1/f = (n - 1) (1/R_1 - 1/R_2) = (1.5 - 1) * (1/-0.04 - 1/0.04) \text{ m}^{-1} = -1/0.04 \text{ m}^{-1}$$

$$f = -0.04 \text{ m}$$

9.4 PRACTICE QUIZ 9.2

Choose the best answer. Answers can be found at the back of the book.

1. Which of the following is a correct statement?
 - A. None of the other choices are correct.
 - B. The focal point of a convex lens is virtual.
 - C. The focal point of a concave lens is real.
 - D. The focal point of a convex lens is the point from which light rays parallel to the principal axis seem to come from after refraction.
 - E. The focal point of a concave lens is the point from which light rays parallel to the principal axis seem to come from after refraction.

SMS from your computer

...Sync'd with your Android phone & number

FREE
30 days trial!

Go to

BrowserTexting.com

and start texting from
your computer!

 **BrowserTexting**

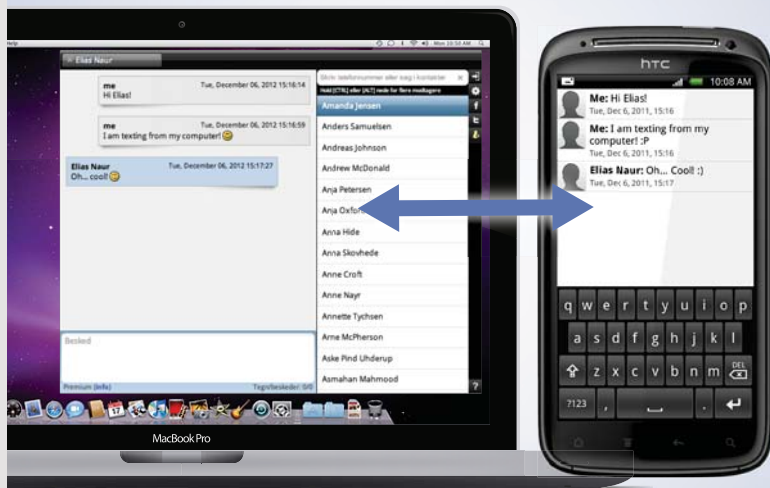

2. Which of the following is a correct statement?
 - A. A light ray parallel to the principal axis of a concave lens is refracted through the focal point of the lens.
 - B. A light ray through the focal point of a concave lens is refracted parallel to the principal axis.
 - C. All of the other choices are not correct.
 - D. A light ray through the focal point of a convex lens passes undeflected.
 - E. A light ray parallel to the principal axis of convex lens is refracted through the focal point.

3. When an object is placed at a distance greater than the focal length but less than twice the focal length from a convex lens
 - A. the image is virtual.
 - B. All of the other choices are not correct.
 - C. the image is formed on the same side as the object.
 - D. the image is inverted.
 - E. the image is diminished.

4. When an object is placed between a convex lens and its focal point,
 - A. the image is formed on the side of the lens as the object.
 - B. the image is inverted.
 - C. the image is diminished.
 - D. the image is real.
 - E. None of the other choices are correct.

5. When an object is placed at a distance greater than twice the focal length from a convex lens,
 - A. the image is erect.
 - B. the image is real.
 - C. the image is enlarged.
 - D. None of the other choices are correct.
 - E. the image is formed between the lens and the focal point of the lens.

6. For an object placed in front of a concave lens,
 - A. the image is formed on the same side as the object.
 - B. the image is always enlarged.
 - C. the image is always inverted.
 - D. the image may be real or virtual.
 - E. the image is always real.

7. An object of height 0.02 m is placed 0.18 m in front of a convex lens whose focal length is 0.03 m. Calculate the height of the image.
- A. $-0.52e-2$ m
 - B. $-0.44e-2$ m
 - C. $-0.32e-2$ m
 - D. $-0.4e-2$ m
 - E. $-0.24e-2$ m
8. An object of height 0.03 m is placed 0.2 m in front of a concave lens whose focal length is 0.04 m. Calculate the magnification.
- A. 0.133
 - B. 0.183
 - C. 0.233
 - D. 0.217
 - E. 0.167
9. The two radii of curvatures of a convex lens, made of glass, are 0.05 m and 0.02 m. Calculate the focal length of the lens. (Refractive index of glass is 1.5).
- A. $-7.333e-2$ m
 - B. $-2.857e-2$ m
 - C. $2.857e-2$ m
 - D. $-6.667e-2$ m
 - E. $6.667e-2$ m
10. The two radii of curvatures of a concave lens, made of glass, are 0.07 m and 0.1 m. Calculate the focal length of the lens. (Refractive index of glass is 1.5).
- A. $-8.235e-2$ m
 - B. $42e-2$ m
 - C. $8.235e-2$ m
 - D. $-42e-2$ m
 - E. $46.667e-2$ m

10 WAVE PROPERTIES OF LIGHT

Your goals for this chapter are to learn about interference of light, diffraction of light, and polarization of light.

10.1 INTERFERENCE OF LIGHT

Interference of Light is the meeting of two or more light waves at the same point at the same time. The net instantaneous effect of the interfering waves is obtained by adding the instantaneous values of the waves algebraically. The net effect of the interfering waves $y_1 = A_1 \cos(\omega t - kx_1)$ and $y_2 = A_2 \cos(\omega t - kx_2)$ is given as $y_{net} = y_1 + y_2 = A_1 \cos(\omega t - kx_1) + A_2 \cos(\omega t - kx_2)$.

Constructive interference is interference with the maximum possible effect. For light waves, constructive interference results in a bright spot. The amplitude of the net wave of two interfering waves is equal to the sum of the amplitudes of the interfering waves. It occurs when the phase shift (δ) between the interfering waves is an integral multiple of 2π . The following equation is the condition for constructive interference.

$$\delta_n = 2n\pi$$

YOUR WORK AT TOMTOM WILL
BE TOUCHED BY MILLIONS.
AROUND THE WORLD. EVERYDAY.

Join us now on www.TomTom.jobs

follow us on **LinkedIn**



#ACHIEVEMORE

TOMTOM 

Where n is an integer; that is, n is a member of the set $\{\dots -2, -1, 0, 1, 2, \dots\}$ and δ_n is a member of the set $\{\dots -4\pi, -2\pi, 0, 2\pi, 4\pi, \dots\}$.

Destructive interference is interference with the minimum possible effect. For light waves, destructive interference results in a dark spot. The amplitude of the net wave of two interfering waves is equal to the difference between the amplitudes of the interfering waves. It occurs when the phase shift between the interfering waves is an odd-integral multiple of π . The following equation is the condition for destructive interference.

$$\delta_n = (2n + 1)\pi$$

Where n is integer; that is n is a member of the set $\{\dots -2, -1, 0, 1, 2, 3, \dots\}$ and δ_n is a member of the set $\{\dots -3\pi, -\pi, \pi, 3\pi, \dots\}$.

Example: Determine if the following waves will interfere constructively, destructively, or neither constructively nor destructively.

a) $y_1 = 5 \cos(20t + \pi)$ and $y_2 = 7 \cos(20t + 4\pi)$.

Solution: $\beta_1 = \pi$; $\beta_2 = 4\pi$; $\delta = ?$

$$\delta = \beta_2 - \beta_1 = 4\pi - \pi = 3\pi$$

The two waves will interfere destructively because $\delta = 3\pi$ is a member of the set $\{\dots -3\pi, -\pi, \pi, 3\pi, \dots\}$

$y_1 = 30 \cos(40t + \pi/2)$ and $y_2 = 80 \cos(40t + 7\pi)$.

Solution: $\beta_1 = \pi/2$; $\beta_2 = 7\pi$; $\delta = ?$

$$\delta = \beta_2 - \beta_1 = 7\pi - \pi/2 = 13\pi/2$$

The two waves will interfere neither constructively nor destructively because $\delta = 13\pi/2$ is not a member of the set $\{\dots -3\pi, -\pi, \pi, 3\pi, \dots\}$ or the set $\{\dots -4\pi, -2\pi, 0, 2\pi, 4\pi, \dots\}$

$y_1 = 2 \cos(50t - 5\pi/2)$ and $y_2 = 80 \cos(50t - \pi/2)$.

Solution: $\beta_1 = -5\pi/2$; $\beta_2 = -\pi/2$; $\delta = ?$

$$\delta = \beta_2 - \beta_1 = -\pi/2 - (-5\pi/2) = 2\pi$$

The two waves will interfere constructively because $\delta = 2\pi$ is a member of the set $\{\dots -4\pi, -2\pi, 0, 2\pi, 4\pi, \dots\}$

The conditions of constructive and destructive interference can also be expressed in terms of the path difference (difference between the distances travelled by the two waves) between the two waves. If the two interfering waves are given as $y_1 = A_1 \cos(\omega t - kx_1)$ and $y_2 = A_2 \cos(\omega t - kx_2)$ (where $k = 2\pi/\lambda$), then the phase shift between the two waves is $\delta = 2\pi x_2/\lambda - 2\pi x_1/\lambda = (2\pi/\lambda)(x_2 - x_1) = (2\pi/\lambda)\Delta$ where $\Delta = x_2 - x_1$ is the path difference between the two waves. The condition of constructive interference may be written in terms of path difference as $\delta_n = 2n\pi = (2\pi/\lambda)\Delta_n$. This implies that the path difference between two waves has to satisfy the following condition for constructive interference.

$$\Delta_n = n\lambda$$

Where n is an integer; that is n is a member of the set $\{\dots -2, -1, 0, 1, 2, \dots\}$ and Δ_n is a member of the set $\{\dots -2\lambda, -\lambda, 0, \lambda, 2\lambda, \dots\}$. Two waves will interfere constructively if their path difference is an integral multiple of the wavelength of the waves.

The condition of destructive interference can be written in terms of path difference as $\delta_n = (2n + 1)\pi = (2\pi/\lambda)\Delta_n$. This implies that the path difference between two waves has to satisfy the following condition if the waves are to interfere destructively.

$$\Delta_n = (n + 1/2)\lambda$$

where n is integer; that is n is a member of the set $\{\dots -2, -1, 0, 1, 2, \dots\}$ and Δ_n is a member of the set $\{\dots -3\lambda/2, -\lambda/2, \lambda/2, 3\lambda/2, \dots\}$. Two waves will interfere destructively if their path difference is half-odd-integral multiple of the wavelength.

10.1.1 DIFFRACTION OF LIGHT

Diffraction of light is the bending of light as light encounters an obstacle. Light travels in a straight line. But when light encounters an obstacle it scatters in all directions. When light is blocked by an opaque object, it can be still seen behind the opaque object because of diffraction of light at the edges of the object. A large part of a room can be seen through a key hole even though light travels in straight lines. This is because of diffraction of light at the key hole which bends the light. This property of light enables one to use a narrow slit as a source of light because as light crosses the slit it is scattered in all directions.

10.1.2 YOUNG'S DOUBLE SLIT EXPERIMENT

The following diagram shows the setup of Young's double slit experiment.

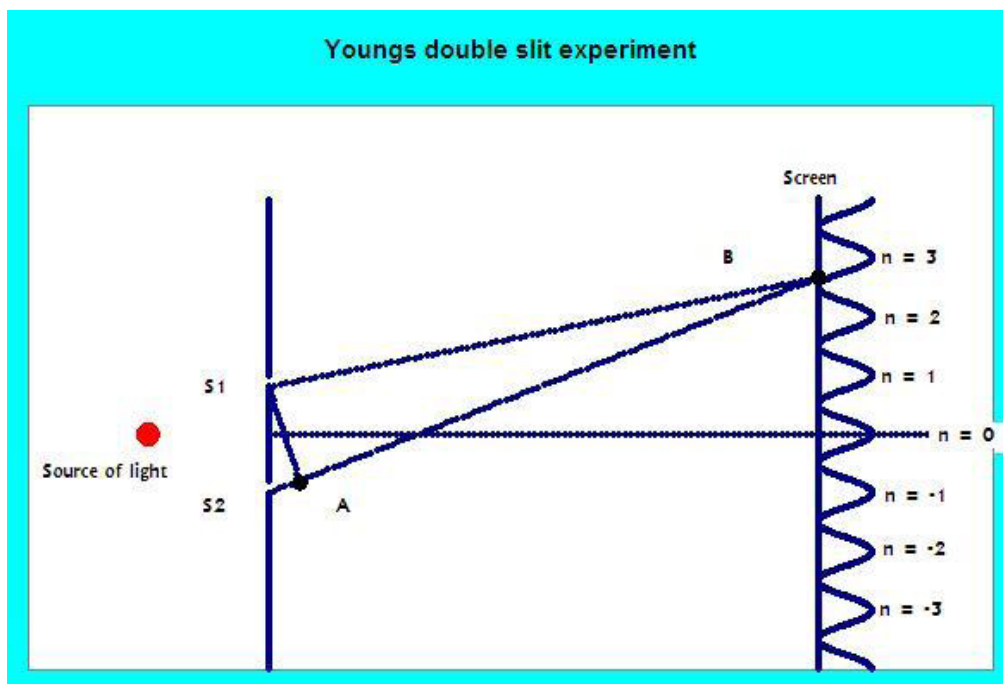

Figure 10.1

Brain power

By 2020, wind could provide one-tenth of our planet's electricity needs. Already today, SKF's innovative know-how is crucial to running a large proportion of the world's wind turbines.

Up to 25 % of the generating costs relate to maintenance. These can be reduced dramatically thanks to our systems for on-line condition monitoring and automatic lubrication. We help make it more economical to create cleaner, cheaper energy out of thin air.

By sharing our experience, expertise, and creativity, industries can boost performance beyond expectations. Therefore we need the best employees who can meet this challenge!

The Power of Knowledge Engineering

Plug into The Power of Knowledge Engineering.
Visit us at www.skf.com/knowledge

Young's double slit experiment consists of an opaque material with two very narrow slits (s_1 and s_2 in the diagram) and a screen at some distance from this material. When the opaque material is exposed to a source of light, the two slits serve as two sources of light because light is diffracted in all directions as it passes through the slits. The light waves from the two slits interfere on the screen. The diagram shows light waves from the two slits interfering at point B. The experiment shows that bright (constructive interference) and dark (destructive interference) spots appear alternatively on the screen. The graph on the screen is a representation of the intensity of light observed on the screen. The interference pattern observed on the screen depends on the path difference between the two waves. If the path difference is an integral multiple of the wavelength of the light, the two waves interfere constructively and a bright spot is observed. If the path difference is half-odd-integral multiple of the wavelength of the light, destructive interference takes place and a dark spot is observed. At the center of the screen the two waves travel the same distance and the path difference is zero which implies constructive interference and a bright spot is observed. This corresponds to $n = 0$ and is called the zeroth order. As one goes further from the center, the path difference between the waves increases. At a point where the path difference is half of the wavelength, destructive interference takes place and a dark spot is observed. This way, as the path difference alternates between integral multiples of the wavelength and half-odd-integral multiples of the wavelength, the interference pattern alternates between bright spots and dark spots. The n^{th} bright spot is called the n^{th} order bright spot.

The path difference between the waves from slit s_1 and slit s_2 can be obtained by dropping the perpendicular from slit s_1 to the light wave from slit s_2 (the line joining slit s_1 and point A in the diagram). Then the path difference (δ) is the distance between slit s_2 and point A. If the distance between the slits is d and the angle formed between the line joining the slits and the line joining slit s_1 and point A is θ (This angle is also equal to the angle formed by the line joining the midpoint of the slits to point B with the horizontal), then the path difference is given as $\delta = d \sin (\theta)$. Therefore the condition for constructive interference (bright spot) for Young's double slit experiment is

$$d \sin (\theta) = n\lambda$$

Where n is an integer and λ is the wavelength of the light. Similarly, the condition for destructive interference (dark spot) is

$$d \sin (\theta) = (n + 1/2)\lambda$$

If the perpendicular distance between the source and the screen is D , then the vertical distance (y) between the the center of the screen (zeroth order bright spot) and an order corresponding to an angle θ is given by

$$y = D \tan (\theta)$$

Example: In Young's double slit experiment, the slits are separated by a distance of $2e-6$ m. The second order bright spot is observed at an angle of 26° .

- a) Calculate the wavelength of the light.

Solution: $d = 2e-6$ m; $\theta = 26^\circ$; $n = 2$; $\lambda = ?$

$$d \sin (\theta) = n\lambda$$

$$\lambda = d \sin (\theta) / n = 2e-6 * \sin (26^\circ) / 2 \text{ m} = 4.4e-7 \text{ m}$$

- b) If the perpendicular distance between the source and the screen is 0.05 m, calculate the distance between the zeroth order bright spot and the second order bright spot on the screen.

Solution: $D = 0.05$ m; $\theta = 26^\circ$; $y = ?$

$$y = D \tan (\theta)$$

$$y = 0.05 * \tan (26^\circ) = 0.024 \text{ m}$$

10.1.3 THIN FILM INTERFERENCE

When light of wavelength λ is incident on a thin film of refractive index n , some of the light rays will be reflected from the upper surface, and some of the light rays will be refracted to the lower surface and reflected from the lower surface and then refracted back to air. These two light rays will interfere and create interference pattern. There are two factors that contribute to the phase difference between the two waves:

- a) the path difference between the two waves. If the thickness of the film is t and the incident light rays are approximately perpendicular to the surface, the path difference is $2t$. Since the wavelength of the light in the film is λ/n , this corresponds to a phase difference of $2\pi(2t/(\lambda/n))$ radians = $2\pi(2tn/\lambda)$ radians.

- b) the phase difference due to phase shift on reflection from an optically denser medium. The light rays reflected from the upper surface will have a phase shift of π radians because they are being reflected from an optically denser medium (film) while the light rays reflected from the lower surface will not have a phase shift, because they are being reflected from an optically less dense medium (air). Thus, the two waves will have a phase shift of π radians due to reflection.

Therefore the net phase difference between the two waves is $2\pi(2nt/\lambda) + \pi$. This implies that the condition for constructive interference is $2\pi(2nt/\lambda) + \pi = 2m\pi$ where m is a natural number, or

$$2nt = (m - 1/2) \lambda$$

Similarly, the condition for destructive interference is $2\pi(2nt/\lambda) + \pi = (2m + 1) \pi$ where m is a natural number, or

$$2nt = m \lambda$$



> Apply now

REDEFINE YOUR FUTURE
**AXA GLOBAL GRADUATE
PROGRAM 2015**

redefining / standards 

agence.café - © Photonostop

Example: Calculate the thickness of a thin film of refractive index 1.3 that results in a second order bright spot, when light rays of wavelength $7e-7$ m are incident on the film approximately perpendicularly.

Solution: $n = 1.3$; $\lambda = 7e-7$ m; $m = 2$; $t = ?$

$$2nt = (m - 1/2) \lambda$$

$$t = (m - 1/2) \lambda / (2n) = (2 - 1/2) * 7e-7 / (2 * 1.3) \text{ m} = 4.038e-7 \text{ m}.$$

10.1.4 SINGLE SLIT DIFFRACTION

When light enters a slit whose width is of the same order as the wavelength of the light, it will be diffracted and each point of the slit can be considered as a source of light. The light waves from each point of the slit meet on a screen and form interference pattern. The interference of all of the waves can be regrouped into pairs of waves and then added. Imagine the slit being divided into half. If the width of the slit is a , for every wave in the lower half, there is a wave in the upper half at a distance of $a/2$. If the waves are grouped into pairs of waves with the distance between their sources being $a/2$, then the condition for destructive (constructive) interference becomes the same for all of the pairs, and thus the condition of interference can be applied to one of the pairs only. As discussed earlier, if the distance between the sources is $a/2$, then the path difference between the waves is $a \sin(\theta)/2$ where θ is defined in the same way as above. Therefore there will be destructive interference, if the path difference is equal to half of the wavelength or if $a \sin(\theta) = \lambda$. The same argument can be repeated by imagining the slit to be divided into 2, 4, ... N parts and regrouping the waves into pairs of waves whose sources are separated by a distance of a/N and the following general formula for destructive interference can be obtained.

$$a \sin(\theta) = n\lambda$$

Where n is an integer.

10.1.5 DIFFRACTION GRATING

A *diffraction grating* is a piece of glass with a lot of slits spaced uniformly. Again we can imagine the waves being grouped into pairs before being added. If each slit is grouped with the slit next to it, then the distance between the slits for each pair of waves will be the same (which is the distance between two neighboring slits). This means the condition of interference is the same for all of the pairs of waves. As a result the condition of interference can be applied to one of the pairs only. If the slits are separated by a distance d , then the path difference between the waves of a pair is $d \sin (\theta)$ (with θ as defined above). Therefore, the conditions of constructive and destructive interference respectively are

$$d \sin (\theta) = n\lambda$$

$$d \sin (\theta) = (n + 1/2) \lambda$$

Where n is an integer.

Example: A diffraction grating has 10000 slits. Its width is 0.02 m. When a certain light wave is diffracted through it, the first bright spot was observed at an angle of 16° . Calculate, the wavelength of the light.

Solution: The separation between the slits (d) may be obtained by dividing the width of the diffraction grating by the number of slits.

Width = 0.02 m, number of slits = 1000; $d = 0.02/10000$ m = $2e-6$ m; $\theta = 16^\circ$; $n = 1$; $\lambda = ?$

$$d \sin (\theta) = n\lambda$$

$$\lambda = d \sin (\theta) / n = 2e-6 * \sin (16^\circ) / n = 5.5e-7 \text{ m}$$

10.2 POLARIZATION

Electromagnetic waves (light is an electromagnetic wave) are transverse waves which means the electric and magnetic fields are perpendicular to the direction of propagation of energy. This limits the direction of the electric field to the plane perpendicular to the direction of propagation of energy. But it can have any direction on that plane. Normally light will include electric fields with all of the possible directions (because light is produced with charges accelerating in no preferred direction). Such kind of light is called an unpolarized light. But when light passes through some materials (devices) called polarizers, there will be a preferred direction and the electric field will vibrate in a certain fixed direction. Such light where the electric field vibrates only in a certain fixed direction is called *linearly polarized light*.

Polarized light may be created by selective absorption. There are some materials whose molecules vibrate only in a certain direction. When light passes through such kind of materials, the component of the electric field in the direction of vibration of the molecules will be absorbed because it will be used to accelerate the charges. Only the perpendicular component (which has a unique direction because to start with the directions were limited to a plane) will pass through unaffected. As a result the outcome is light where the electric field vibrates in a fixed direction which is linearly polarized light.

LIGS University based in Hawaii, USA

is currently enrolling in the
Interactive Online **BBA, MBA, MSc,**
DBA and PhD programs:

- ▶ enroll **by October 31st, 2014** and
- ▶ **save up to 11%** on the tuition!
- ▶ pay in 10 installments / 2 years
- ▶ Interactive **Online education**
- ▶ visit www.ligsuniversity.com to find out more!

Note: LIGS University is not accredited by any nationally recognized accrediting agency listed by the US Secretary of Education. More info [here](#).



Polarized light also may be created by reflection. When light is incident on a boundary between two mediums some of the light will be refracted and some of the light will be reflected. The component of the electric field parallel to the surface and the component perpendicular to the surface reflect differently. The component parallel to the surface reflects more strongly. In fact, at a certain angle of incidence θ_p , where the reflected ray and the refracted ray are perpendicular to each other, the refracted ray will contain only the component parallel to the surface resulting in a polarized light. For this special incident rays, the sum of the angle of incidence (θ_p) and angle of refraction (θ_r) is 90° . Or, $\theta_r = 90^\circ - \theta_p$. Assuming the light ray is entering a medium of refractive index n_2 from a medium of refractive index n_1 , $n_2/n_1 = \sin(\theta_p)/\sin(90^\circ - \theta_p) = \sin(\theta_p)/\cos(\theta_p) = \tan(\theta_p)$. This special angle of incidence that results in a purely polarized light is called *polarizing angle* and is given by

$$\theta_p = \arctan(n_2/n_1)$$

This relationship is called *Brewster's law*.

10.3 PRACTICE QUIZ 10

Choose the best answer. Answers can be found at the back of the book.

1. Which of the following is a correct statement?
 - A. When two waves interfere, the amplitude of the net wave is always equal to the sum of the amplitudes of the interfering waves.
 - B. When two waves interfere, the amplitude of the net wave is always equal to the difference between the amplitudes of the interfering waves.
 - C. Interference of two waves is the meeting of two waves at the same point at the same time.
 - D. Diffraction is the bending of light as light crosses the boundary between two optical mediums.
 - E. All of the other choices are correct statements.
2. Which of the following is a correct statement?
 - A. Two waves of the same frequency interfere destructively only if their phase difference is an integral multiple of 180° .
 - B. Two waves interfere destructively only if their path difference is half of odd integral multiple of their wavelength.
 - C. None of the other choices are correct.
 - D. Two waves of the same frequency interfere constructively only if their path difference is an even integral multiple of their wavelength.
 - E. Two waves of the same frequency interfere constructively, only if their phase difference is 0° .

3. Which of the following pair of waves interfere constructively?
- A. $x = 10 \sin (30t + \pi)$ and $y = 20 \sin (30t + 4 * \pi)$
 - B. $x = 10 \sin (30t + \pi/2)$ and $y = 20 \sin (30t + 7 * \pi/2)$
 - C. $x = 10 \sin (30t + \pi/2)$ and $y = 20 \sin (30t + \pi)$
 - D. $x = 10 \sin (30t + \pi)$ and $y = 20 \sin (30t + 5 * \pi)$
 - E. $x = 10 \sin (30t + \pi)$ and $y = 20 \sin (30t)$
4. Which of the following pair of waves interfere destructively?
- A. $x = 10 \sin (30t + \pi/2)$ and $y = 20 \sin (30t + 5 * \pi/2)$
 - B. $x = 10 \sin (30t + 2 * \pi)$ and $y = 20 \sin (30t)$
 - C. $x = 10 \sin (30t + \pi/2)$ and $y = 20 \sin (30t + \pi)$
 - D. $x = 10 \sin (30t + \pi)$ and $y = 20 \sin (30t + 4 * \pi)$
 - E. $x = 10 \sin (30t + \pi)$ and $y = 20 \sin (30t + 5 * \pi)$
5. In Young's double slit experiment, the slits are separated by a distance of $3.28e-6$ m. If the third order bright spot is formed at an angle of 38° , calculate the wave length of the light.
- A. $942.372e-9$ m
 - B. $605.811e-9$ m
 - C. $471.186e-9$ m
 - D. $673.123e-9$ m
 - E. $538.499e-9$ m
6. In Young's double slit experiment, the slits are separated by a distance of $3.26e-6$ m. If the fourth order dark spot is formed at an angle of 32° , calculate the wave length of the light.
- A. $537.456e-9$ m
 - B. $268.728e-9$ m
 - C. $383.897e-9$ m
 - D. $345.507e-9$ m
 - E. $307.118e-9$ m

11 RELATIVITY AND QUANTUM MECHANICS

Your goals for this experiment are to learn about relativity, Planck's postulates, photoelectric effect experiment, De Broglie's hypothesis, Schrodinger's equation, and Heisenberg's uncertainty principle.

11.1 THE HISTORY OF MODERN PHYSICS

Physics developed before early 1900s is called *classical physics*. Classical physics is largely the physics developed by Isaac Newton (mechanics) and Karl Maxwell (electromagnetic theory). The physics developed after early 1900s is called *modern physics*.

In the late 1800s physicists pretty much felt they knew everything they need to know about physics. But in the late 1800s and early 1900s some experiments were done which classical physics failed to explain. These experiments gave rise to the emergence of a new kind of physics. These experiments were the Michelson-Morley experiment, the blackbody radiation experiment, and the photoelectric experiment.

TURN TO THE EXPERTS FOR SUBSCRIPTION CONSULTANCY

Subscribe is one of the leading companies in Europe when it comes to innovation and business development within subscription businesses.

We innovate new subscription business models or improve existing ones. We do business reviews of existing subscription businesses and we develop acquisition and retention strategies.

Learn more at [linkedin.com/company/subscribe](https://www.linkedin.com/company/subscribe) or contact Managing Director Morten Suhr Hansen at mha@subscribe.dk

SUBSCR✓**BE** - to the future

11.2 THE MICHELSON-MORLEY EXPERIMENT

According to classical physics theory of transformation (Galilean transformation), if light is emitted by a source moving with a speed v , the speed of light is expected to increase by v ; that is the speed of light is expected to be $c + v$ where $c = 3e8$ m/s. But the Michelson-Morley experiment found out that the speed of light is independent of the speed of the source; that is, it is always $3e8$ m/s whatever the speed of its source might be. Thus, Galilean transformation had to be modified. To accommodate for this new experimental finding Albert Einstein developed a new theory called *Special Theory of Relativity* based on the following two postulates:

1. The speed of light is independent of the speed of the source.
2. All coordinate systems moving with a constant velocity with respect to each other are equivalent.

This theory led to some conclusions that contradicted common sense but which were later proved to be correct. Some of these were

- a) Mass and energy are equivalent and interchangeable. If a sample of mass m is completely converted to energy, the amount of energy (E) is related with the mass (m) by

$$E = mc^2$$

Where c is the speed of light. In atomic and nuclear bombs the energy is obtained by converting mass to energy.

Example: Calculate the amount of energy that can be obtained from a sample of mass 5 mg when the sample is completely converted to energy.

Solution: $m = 5 \text{ mg} = 5e-3 \text{ g}$; $E = ?$

$$E = mc^2 = 5e-3 * 3e8^2 \text{ J} = 4.5e13 \text{ J}$$

- b) As speed increases length decreases. A device that is moving with respect to an object whose length is to be measured measures smaller length than a device that is at rest with respect to the object. If the length measured by a device at rest with respect to the object is L_0 and the length measured by a device moving with a speed v with respect to the object is L , then

$$L = L_0 \sqrt{1 - (v/c)^2}$$

Where c is the speed of light.

Example: The length of an object as measured by a device at rest with respect to the object is 2 m. Calculate the length of the object by means of a device moving with a speed of $4e6$ m/s.

Solution: $L_0 = 2$ m; $v = 4e6$ m/s; $L = ?$

$$L = L_0 \sqrt{1 - (v/c)^2} = 2 * \sqrt{1 - (4e6/3e8)^2} \text{ m} = 1.99982 \text{ m}$$

- c) As speed increases time decreases. The time interval measured by a device moving with respect to an event is less than the time interval measured by a device at rest with respect to the event. If t_0 is time interval measured by a device at rest with respect to the event and t is time interval measured by a device moving with a speed v with respect to the event, then

$$t = t_0 \sqrt{1 - (v/c)^2}$$

Example: The time interval for a certain event as measured by a device at rest with respect to the event is 2000 s. Calculate the time interval as measured by a device moving with a speed of half of the speed of light with respect to the event.

Solution: $t_0 = 2000$ s; $v = 0.5c$; $t = ?$

$$t = t_0 \sqrt{1 - (v/c)^2} = 2000 * \sqrt{1 - (0.5c/c)^2} \text{ s} = 1732 \text{ s}$$

- d) As speed increases, mass increases. A device moving with respect to an object whose mass is to be measured measures a mass greater than a device at rest with respect to the object. If the mass measured by a device at rest with respect the object (rest mass) is m_0 and the mass measured by a device moving with a speed v with respect to the object is m , then

$$m = m_0 / \sqrt{1 - (v/c)^2}$$

Example: The rest mass of an object is 3 kg. Calculate its mass measured by a device moving with 90% of the speed of light.

Solution: $m_0 = 3$ s; $v = 0.9c$; $m = ?$

$$m = m_0 / \sqrt{1 - (v/c)^2} = 3 / \sqrt{1 - (0.9c/c)^2} \text{ kg} = 6.9 \text{ kg}$$



"I studied English for 16 years but...
...I finally learned to speak it in just six lessons"

Jane, Chinese architect

ENGLISH OUT THERE

Click to hear me talking before and after my unique course download

11.3 THE BLACK BODY RADIATION EXPERIMENT

The black body radiation experiment was done to study the intensity distribution as a function of wavelength for the radiation emitted by a hot object. Classical physics failed to explain this experiment. Max Planck was able to explain this experiment based on the following two postulates:

1. Light is propagated in the form of particles called photons.
2. The energy of a photon (E) is directly proportional to the frequency (f) of the light.

$$E = hf$$

The constant of proportionality, h , is a universal constant called Planck's constant and its value is $6.6e-34$ J/s.

$$h = 6.6e-34 \text{ J/s}$$

The energy of a number of photons is obtained by multiplying the energy of one photon by the number of photons.

$$E_n = nhf$$

Where n is the number of photons and E_n is the energy of the n photons. These two postulates led to the emergence of a new kind of physics called quantum physics which is mainly used at the atomic level.

Example: Calculate the energy of 5000 photons of violet light. The wavelength of violet light is 400 nm.

Solution: $n = 5000$; $\lambda = 400 \text{ nm} = 400e-9 \text{ m} = 4e-7 \text{ m}$ ($f = c/\lambda$); $E_n = ?$

$$E_n = nhf = nhc/\lambda$$

$$E_{5000} = 5000 * 6.6e-34 * 3e8 / 4e-7 \text{ J} = 2.5e-15 \text{ J}$$

11.4 THE PHOTOELECTRIC EFFECT EXPERIMENT

When a metallic surface is exposed to light, electrons are emitted from the surface. This is called the photoelectric effect. The photoelectric effect experiment was done to study the energy of the emitted electrons. Classical physics predicted that the energy of the emitted electrons would depend on the intensity of the light. But the photoelectric effect experiment found out that the energy of the emitted electrons depends on the frequency of the light and not on the intensity of light. Albert Einstein was able to explain this experiment successfully by making use of Planck's postulates. According to Einstein, since light is propagated in the form of particles, it is unlikely for an electron to be hit by more than one photon at the same time. Thus, the energy of the emitted electrons depends on the energy of one photon which in turn depends on frequency and not on the number of photons which is a measure of intensity.

The minimum amount of energy required to remove an electron from a surface is called the *work function* (w) of the surface. When a photon hits an electron, some of the energy of the photon will be used to remove the electron from the surface. The remaining energy is converted to the kinetic energy of the emitted electron. Since the most loosely held electron requires the least amount of energy (which is equal to the work function of the surface), it will be emitted with the maximum kinetic energy (KE_{max}). Thus, when the most loosely held electron is hit by light of frequency f , the following equation holds for the most loosely held electron.

$$hf = w + KE_{max}$$

Example: A metallic surface of work function 2 eV is exposed to violet light. Calculate the maximum kinetic energy of the emitted electrons. Wavelength of violet light is $4e-7$ m.

Solution: eV (electron Volt) is a unit of energy equal to $1.6e-19$ J.

$$\lambda = 4e-7 \text{ m } (f = c/\lambda); w = 2 \text{ eV} = 2 * 1.6e-19 \text{ J} = 3.2e-19 \text{ J}; KE_{max} = ?$$

$$f = c/\lambda = 3e8/4e-7 \text{ Hz} = 7.5e14 \text{ Hz}$$

$$hf = w + KE_{max}$$

$$KE_{max} = hf - w = (6.6e-34 * 7.5e14 - 3.2e-19) \text{ J} = 1.7e-19 \text{ J}$$

The photoelectric experiment is a demonstration of the particle property of light because a single photon as an entity knocks out an electron from the surface of a metal. The particle nature of light was further demonstrated by an experiment known as *Compton's effect* which showed that a photon (light) collides with an electron like a particle changing direction and energy (wavelength) to satisfy the principles of conservation of momentum and energy.

11.5 DE BROGLIE'S HYPOTHESIS

De Broglie's hypothesis states that if waves have particle properties, then particles also should have wave properties. De Broglie obtained an expression for the wavelength of particles by replacing c by speed of a particle v in the equations of light. $E = hf = hc/\lambda \Rightarrow E = hv/\lambda$ and $E = mc^2 \Rightarrow E = mv^2$. Equating both expressions of E : $mv^2 = mv/\lambda$. Thus, De Broglie wavelength of a particle is given as follows:

$$\lambda = h/(mv)$$

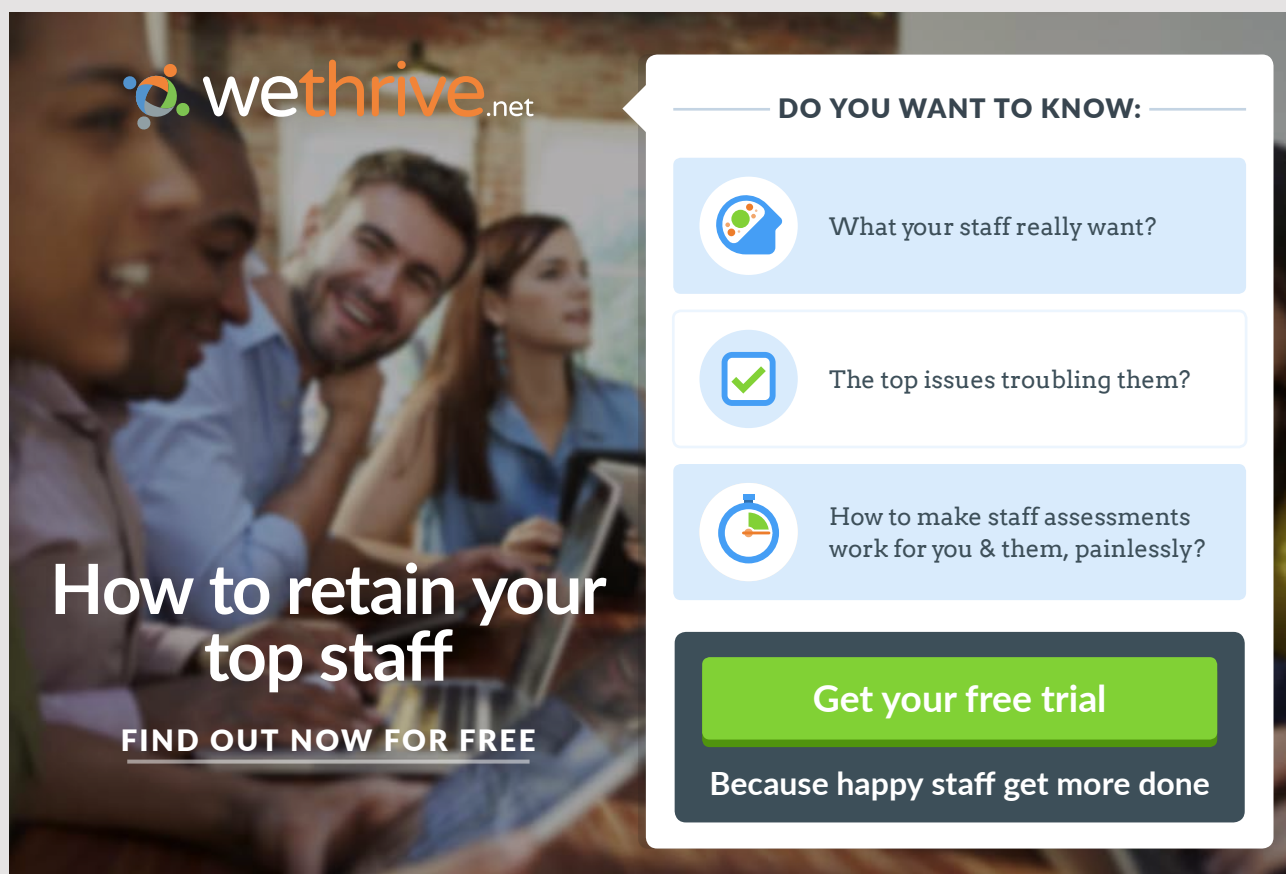

wethrive.net

How to retain your top staff
FIND OUT NOW FOR FREE

DO YOU WANT TO KNOW:

- What your staff really want?
- The top issues troubling them?
- How to make staff assessments work for you & them, painlessly?

Get your free trial
Because happy staff get more done

Example: Calculate the De Broglie wavelength of an electron (mass $9.1e-31$ kg) when moving with a speed of $5e6$ m/s.

Solution: $m = 9.1e-31$ kg; $v = 5e6$ m/s; $\lambda = ?$

$$\lambda = h/(mv) = 6.6e-34/(9.1e-31 * 5e6) \text{ m} = 1.5e-10 \text{ m}$$

De Broglie hypothesis was proved to be correct experimentally by two American scientists by the name Davisson and Germer who proved that electrons have wave properties such as interference.

11.6 SCHRODINGER'S EQUATION

A scientist by the name Erwin Schrodinger developed an equation for determining the wave properties of particles. The equation solves for a function called *wave function* of the particle, commonly represented as $\psi(x)$. The physical meaning of this function was stated by a scientist by the name Born. Born stated that the square of the wave function ($\psi(x)^2$) at a given location represents the probability density of locating the particle at the given location. When the square of a wave function at a given location is multiplied by a small volume element containing the location ($\psi(x)^2 dx$), it represents the probability of locating the particle at the given location. It follows that in quantum mechanics, we can deduce only the probability of locating a particle at a certain location and not the exact location. The mathematics involved in Schrodinger's equation is beyond the scope of this treatment. But, basically, the time independent form of the equation states that the rate of change of the rate of change of the wave function with respect to position (second derivative of the wave function with respect to position in the language of calculus) is proportional to the product of the kinetic energy and the wave function.

11.7 HEISENBERG'S UNCERTAINTY PRINCIPLE

Heisenberg's uncertainty principle states that the position and the momentum of a particle cannot be determined accurately at the same time. The lower limit in the uncertainty in measuring momentum is inversely proportional to the uncertainty in measuring position or vice versa. That is, an uncertainty in measuring one of them sets a lower limit in the uncertainty in measuring the other. If the uncertainty in measuring position is small (large), then the uncertainty in measuring momentum will be large (small). In the extreme case where position is measured accurately (zero uncertainty), the uncertainty in measuring momentum will be infinity. Similarly if momentum is measured accurately, then the uncertainty in measuring position will be infinity. Consider a particle whose wave function is a cosine function. It has a unique momentum because it has a unique wavelength (remember the De Broglie momentum of a particle is h/λ). Therefore the uncertainty in measuring momentum is zero. But also a cosine function extends from negative infinity to positive infinity. Which means the probability of locating the particle is uniform throughout space. This is another way of saying the uncertainty in measuring position is infinity as predicted by Heisenberg's uncertainty principle. The following is a mathematical statement of Heisenberg's uncertainty principle.

$$\Delta x \Delta p \geq h / (4\pi)$$

Where Δx and Δp represent uncertainties in measuring position and momentum respectively. h is Planck's constant. This equation implies that if position is measured with an uncertainty Δx , then the uncertainty in measuring momentum cannot be less than $h/(4\pi\Delta x)$. The same uncertainty relationship holds for the measurements of energy and time.

$$\Delta E \Delta t \geq h / (4\pi)$$

Where ΔE and Δt represent the uncertainties in measuring energy and time respectively.

11.8 PRACTICE QUIZ 11

Choose the best answer. Answers can be found at the back of the book.

1. The black body radiation experiment was explained successfully by
 - A. Planck
 - B. Davison and Germer
 - C. Einstein
 - D. De Broglie
 - E. Hertz

2. Which of the following is a correct statement?
- A. One of the postulates of Max Planck states that light is propagated in the form of particles called photons.
 - B. One of the postulates of special theory of relativity states that physical laws have different forms on different coordinate systems.
 - C. One of the postulates of Max Planck states that the energy of a photon of light does not depend on the frequency of the light.
 - D. De Broglie hypothesis states that waves have particle properties.
 - E. The speed of light varies depending on the speed of its source.
3. According to special theory of relativity
- A. as speed increases length increases.
 - B. as speed increases mass decreases.
 - C. the speed of light depends on the speed of its source.
 - D. as speed increases time interval increases.
 - E. Mass and energy are equivalent and interchangeable.

gaiTeye[®]
Challenge the way we run

**EXPERIENCE THE POWER OF
FULL ENGAGEMENT...**

.....

**RUN FASTER.
RUN LONGER..
RUN EASIER...**

**READ MORE & PRE-ORDER TODAY
WWW.GAITEYE.COM**

4. According to classical physics
- A. the speed of light is always a constant independent of the speed of the source.
 - B. none of the other choices are correct.
 - C. particles display not only particle properties but also wave properties.
 - D. the kinetic energy of the electrons emitted by a metallic surface (when it is exposed to light) depends on the intensity of the light.
 - E. light displays not only wave properties but also particle properties.
5. Calculate the amount of energy that can be obtained from a sample of mass $8.21e-10$ kg.
- A. $5.172e7$ J
 - B. $4.433e7$ J
 - C. $8.867e7$ J
 - D. $8.128e7$ J
 - E. $7.389e7$ J
6. The time taken for a certain event as measured by a device at rest with respect to the event is 0.4 s. Calculate the time taken as measured by a device moving with a speed of 80% of speed light with respect to the event.
- A. 0.168 s
 - B. 0.144 s
 - C. 0.288 s
 - D. 0.264 s
 - E. 0.24 s
7. When a metallic surface is exposed to light of wavelength $7e-7$ m, it is found that the maximum kinetic energy of the emitted electrons is 0.6 eV. Calculate the work function of the surface.
- A. 0.701 eV
 - B. 1.168 eV
 - C. 0.818 eV
 - D. 1.051 eV
 - E. 0.934 eV
8. Calculate the De Broglie wavelength of a proton moving with a speed of $8.1e6$ m/s. A proton has a mass of $1.67e-27$ kg.
- A. $0.537e-13$ m
 - B. $0.683e-13$ m
 - C. $0.342e-13$ m
 - D. $0.585e-13$ m
 - E. $0.488e-13$ m

12 ATOMIC PHYSICS

Your goals for this chapter are to learn about the history of the atom, Bohr's model of the atom, and electron configuration of the atom.

12.1 THE HISTORY OF THE ATOM

The atom as the smallest building block of matter was first stated philosophically (without experimental evidence) by the Greek philosopher Democritus in 460 B.C. But the first prediction of the existence of the atom based on experimental evidence was made by John Dalton in the 1800s. The experimental evidence has largely to do with the fact that elements combine in definite proportions to form compounds. The first evidence that the atom is not the smallest particle but is comprised of smaller particles was obtained by J.J. Thomson when he discovered the electron in 1897. Since the atom is neutral, Thomson concluded the atom is made up negative and positive components. Based on this, he proposed a model of the atom where the atom is a positively charged mesh with electrons embedded on it uniformly. In 1911, an experiment was done by Ernest Rutherford to study the structure of the atom. He bombarded a gold foil with alpha particles. An alpha particle is a positively charge particle which is basically a doubly charged helium atom. To his surprise, most of the alpha particles passed through the gold foil undeflected. Only a small portion of them were strongly deflected at certain locations. From this, he concluded, that the positive component of the atom is located on a very small part of the atom and not all over the atom as suggested by Thomson. Based on this finding, Rutherford developed an atomic model known as Rutherford's atomic model. Rutherford's atomic model states that the positive component of the atom is located in a small part of the atom called nucleus with electrons revolving around the nucleus. But the problem with this model was that Maxwell's equations predict that whenever a charge is accelerated, radiation is emitted. Since motion in a curved path is an accelerated motion, this implies that the electron should be losing radiation energy continuously and eventually collapse to the nucleus. Also, Maxwell's equations predict that, the electron should emit a continuous distribution of frequencies as it loses energy. But experiment showed that the atomic spectra (radiation emitted by an atom) contains only few specific frequencies and not a continuous distribution of frequencies. The next attempt to improve the atomic model by putting these shortcomings into consideration was done by Neil's Bohr in 1912.

12.2 BOHR'S MODEL OF THE ATOM

In addition to the shortcomings of the Rutherford model stated above, Bohr had also to put into consideration an empirical formula (Rydberg's formula) for determining the frequencies of the atomic spectra of hydrogen. The basic assumptions made by Bohr were:

1. The electrons revolve only in specific circular orbits and not any orbit. The orbits are restricted by the requirement that the angular momentum of the electron be an integral multiple to the ratio between Planck's constant and 2π or $h/(2\pi)$. Since angular momentum (for a particle revolving in a circular path) $L = I\omega = (mr^2)\omega = m(\omega r)r = mvr$, this condition can be mathematically represented as

$$mvr = nh/(2\pi)$$

This e-book
is made with
SetaPDF

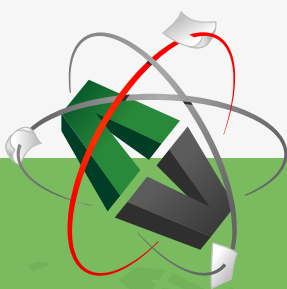

PDF components for PHP developers

www.setasign.com

Where m , v and r are the mass of the electron, speed of the electron and the radius of the orbit respectively. n is an integer. After De Broglie postulated the wavelength of a particle, this condition turned out to be identical with the condition requiring the circumference of the circular orbit to be an integral multiple of the wavelength of the electron's wave. Basically, this condition states that, the wave has to be a standing wave for the orbit to be an allowed orbit. According to De Broglie, $mv = h/\lambda$. Therefore $mvr = hr/\lambda$. Equating this with $nh/(2\pi)$ gives Bohr's condition in terms of the De Broglie's wavelength of the electron.

$$2\pi r = n\lambda$$

- When an electron jumps from one orbit to another, radiation is emitted (absorbed) whose energy is equal to the difference between the energies of both orbits. The frequency of the radiation is obtained according to Planck's law ($E = hf$).

$$\Delta E = hf$$

Where ΔE is the difference between the energies of the orbits and f is the frequency of the radiation emitted (absorbed).

12.2.1 APPLICATION OF BOHR'S MODEL TO THE HYDROGEN ATOM

Bohr used classical physics to obtain the energy of the electron in an orbit. The total energy of an electron in an orbit is the sum of its kinetic and potential energies. The kinetic energy is $mv_n^2/2$, where v_n is the speed of the electron in the n^{th} orbit. The dominant force between the proton and the electron of the hydrogen atom is electrical. Therefore the potential energy is electrical potential energy and is given by $-ke^2/r_n$, where e stands for the charge of the electron and r_n stands for the radius of the n^{th} orbit. Therefore the energy of the n^{th} orbit is given by $E = mv_n^2/2 - ke^2/r_n$. The Energy can be expressed as a function of the radius only by substituting for the speed in terms of the radius by using Newton's second law for circular motion (centripetal force = electrical force or $mv_n^2/r_n = ke^2/r_n^2$).

$$E_n = -ke^2/(2r_n)$$

The radius may be expressed in terms of the orbit number, n , by substituting for speed in Newton's second law for circular motion ($mv_n^2/r_n = ke^2/r_n^2$) in terms of n using Bohr's condition for angular momentum ($mvr = nh/(2\pi)$).

$$r_n = [h^2 / (4\pi^2 m k e^2)] n^2$$

r_n may also be expressed in terms of the lowest radius, r_1 , because $r_1 = h^2 / (4\pi^2 m k e^2)$ which is the coefficient of n^2 .

$$r_n = r_1 n^2$$

The allowed orbit radius varies in direct proportion to the square of the orbit number. For example the radius of the second orbit is four times the radius of the first orbit. With $m = 9.1e-31$ kg, $h = 6.6e-34$ Js, $k = 9e9$ N²m²/C², and $e = 1.6e-19$ C, the lowest radius of the hydrogen atom can be calculated to be

$$r_1 = 5.3e-11 \text{ m}$$

The energy can be expressed as a function of the orbit number by substituting for the radius in terms of the orbit number n .

$$E_n = [-2\pi^2 m k^2 e^4 / h^2] / n^2$$

The coefficient of $1/n^2$ is equal to the energy of the first orbit. ($E_1 = -2\pi^2 m k^2 e^4 / h^2$)

$$E_n = E_1 / n^2$$

The energy of the allowed orbits varies inversely with the square of the orbit number. For example the energy of the second orbit is one fourth of that of the first orbit. The value of the energy of the lowest orbit turns out to be 13.6 eV (remember eV = 1.6e-19 J)

$$E_1 = -13.6 \text{ eV}$$

Example: For the third orbit of the hydrogen atom

a) calculate the radius.

solution: $n = 3$; $r_3 = ?$

$$r_n = r_1 n^2$$

$$r_3 = 5.3e-11 * 3^2 = 4.77e-10 \text{ m}$$

b) calculate the energy.

Solution: $n = 3$; $E_3 = ?$

$$E_n = E_1/n^2$$

$$E_3 = -13.6/3^2 \text{ eV} = -1.511 \text{ eV}$$

The lowest orbit corresponding to $n = 1$ is called the ground state. This is the orbit where the electron of the hydrogen atom resides under normal conditions. The electron can jump to a higher orbit by absorbing energy and it can drop from a higher to a lower orbit by emitting energy (radiation). According to Bohr, the emitted energy is equal to the difference between the energies of the orbits. Suppose an electron drops from an orbit whose orbit number is n_i to an orbit whose orbit number is n_f . Then $\Delta E = E_f - E_i = hf = hc/\lambda$ (using $c = f\lambda$). Replacing the energies with their expressions in terms of their respective orbit numbers, the following expression for the wavelength of the emitted radiation can be obtained.

$$1/\lambda = R(1/n_f^2 - 1/n_i^2)$$



Discover the truth at www.deloitte.ca/careers

Deloitte.

© Deloitte & Touche LLP and affiliated entities.

Where $R = 2\pi^2mk^2e^4 / ch^3$ and is called Rydberg's constant. This formula turned out to be exactly the same with a formula (Rydberg's formula) known earlier empirically. The numerical value of Rydberg's constant is

$$R = 1.097e7 \text{ m}^{-1}$$

The set of radiations emitted when an electron drops from higher orbits to the second orbit is called the Balmer series; and the set of radiations emitted when the electron drops from higher orbits to the first orbit is called the Lyman series.

Example: Calculate the wavelength of the light emitted when the electron of a hydrogen atom drops from the fourth orbit to the second orbit.

Solution: $n_i = 4$; $n_f = 2$; $\lambda = ?$

$$1/\lambda = R(1/n_f^2 - 1/n_i^2)$$

$$1/\lambda = 1.097e7 * (1/2^2 - 1/4^2) = 2.06e6 \text{ m}^{-1}$$

$$\lambda = 4.86e-7 \text{ m}$$

After some spectra that cannot be explained by the Bohr model were discovered, it became very clear that the orbit number cannot account for all of the states of the hydrogen atom. Also, even though the Bohr model was successful with the hydrogen atom, it failed when applied to more complex atoms. According to the current understanding, the state of an electron is identified by four numbers including Bohr's orbit number. These numbers are called quantum numbers.

12.3 QUANTUM NUMBERS

Quantum numbers are numbers used to identify the state of an electron in an atom. There are four quantum numbers. These are known as the n , l , m and s quantum numbers.

1. The n -quantum number, also known as the principal quantum number (This is also the orbit number in Bohr's model). It represents the energy of the electron. The allowed values of n start from 1 and increase in steps of one: $n = 1, 2, 3, \dots$
2. The l -quantum number, also known as the angular momentum quantum number. It represents the angular momentum of the electron. For a given n -quantum number, the allowed l -quantum numbers go from 0 to $n - 1$ in steps of one: $l = 0, 1, 2, \dots, n-1$. That is, for a given n there are n possible l values. For example, the allowed values of l for $n = 3$ are 0, 1, and 2. The l -quantum numbers are customarily represented by letter names. The l -quantum numbers 0, 1, 2, and 3 are respectively represented by the letter names s, p, d, and f.
3. The m -quantum number, also known as the magnetic quantum number (because it manifests itself in the presence of magnetic field). It represents the orientation of the angular momentum of the electron. For a given l -quantum number, the allowed values of m go from $-l$ to l in steps one: $m = -l, \dots, -2, -1, 0, 1, 2, \dots, l$. That is, for a given l , there are $2l + 1$ possible m values. For example, the allowed values of m for $l = 2$ are, -2, -1, 0, 1, and 2.
4. The s -quantum number, also known as the spin quantum number. It represents an intrinsic angular momentum of the electron. It is sometimes referred as the angular momentum related with the rotation of the electron around its axis even though there is no evidence of it being related with the motion of the electron. For a given m -quantum number there are two possible s -quantum numbers identified as $-1/2$ and $1/2$: $s = -1/2, 1/2$.

Since there are $(2l + 1)$ possible m -quantum numbers for a given l -quantum number and there are two spin quantum numbers for each magnetic quantum number, there are $2(2l + 1)$ possible states for a given l -quantum number. For example for $l = 3$, there are $2(2 * 3 + 1) = 14$ possible states. And since there are n l -quantum numbers for a given n -quantum number, there are $2n^2$ possible states corresponding to a given n -quantum number. For example, there are $2 * 2^2 = 8$ possible states corresponding to the $n = 2$ quantum number.

Along with a principle called the Pauli exclusion principle, quantum numbers can be used to determine the electron configuration of atoms. *Pauli exclusion principle* states that no two electrons can have the same set of quantum numbers. This implies that there is a one-to-one correspondence between the set of quantum numbers and the electrons of the atom.

Example: List all the possible states (n, l, m, s) corresponding to the $n = 3$ principal quantum number.

Solution: There are $2 * 3^2 = 18$ possible states. The possible l -quantum numbers are 0, 1, and 2 .

$l = 0, m = 0$ and $s = -1/2, 1/2$ states

$(3, 0, 0, -1/2), (3, 0, 0, 1/2)$

$l = 1, m = -1, 0, 1$ and $s = -1/2, 1/2$ states

$(3, 1, -1, -1/2), (3, 1, -1, 1/2), (3, 1, 0, -1/2), (3, 1, 0, 1/2), (3, 1, 1, -1/2), (3, 1, 1, 1/2)$

$l = 2, m = -2, -1, 0, 1, 2$ and $s = -1/2, 1/2$ states

$(3, 2, -2, -1/2), (3, 2, -2, 1/2), (3, 2, -1, -1/2), (3, 2, -1, 1/2), (3, 2, 0, -1/2),$
 $(3, 2, 0, 1/2), (3, 2, 1, -1/2), (3, 2, 1, 1/2), (3, 2, 2, -1/2), (3, 2, 2, 1/2)$

© 2013 Accenture. All rights reserved.

be > your degree

Bring your talent and passion to a global organization at the forefront of business, technology and innovation. Discover how great you can be.

Visit accenture.com/bookboon

Be greater than.
consulting | technology | outsourcing

accenture
High performance. Delivered.

12.3.1 ELECTRON CONFIGURATION

Electron configuration is the arrangement of the electrons in an atom according to their quantum numbers. Electrons with the same n -quantum number are said to form a shell. And electrons with the same n and l -quantum numbers are said to form a subshell. The electrons in a subshell are symbolically represented as xy^z . x stands for the n -quantum number of the subshell. y stands for the letter name of the l -quantum number of the subshell. z represents the number of electrons in the subshell. For example, consider the subshell represented as $3p^4$. Its principal and angular momentum quantum numbers are 3 and 1 respectively; and it contains four electrons. It is not completely filled because the maximum number of electrons a p-subshell can accommodate is six.

The subshells of an atom are filled with electrons in an increasing order of their energies. This can be accomplished by filling the electrons in an increasing order of the value of $(n + l)$ of the subshells. If two or more subshells have the same $(n + l)$ value, they are filled in an increasing order of n . For example, $4s$ subshell is filled before the $3d$ subshell because $n + l$ is equal to 4 for $4s$ and 5 for $3d$; and $2p$ subshell is filled before $3s$ subshell even though both of them have the same $n + l = 3$ value, because $2p$ subshell has a lower principal quantum number than the $3s$ subshell. The following is an arrangement of the subshells according to these rules:

$$1s^2 2s^2 2p^6 3s^2 3p^6 4s^2 3d^{10} 4p^6 5s^2 4d^{10} 5p^6 6s^2 4f^{14} 5d^{10} 6p^6 7s^2 5f^{14} 6d^{10} 7p^6$$

The number of electrons shown is the maximum number of electrons the subshell can accommodate. The maximum number of electrons that can be accommodated in s, p, d, and f subshells are 2, 6, 10 and 14 respectively.

Example: Write the electron configuration of the first 10 elements of the periodic table (H, He, Li, Be, B, O, N, F, and Ne) whose number of electrons range from one to ten.

Solution: The electrons are filled according to the order of filling of the subshells shown above. Respectively, their electron configurations are:

$$1s^1, 1s^2, 1s^2 2s^1, 1s^2 2s^2, 1s^2 2s^2 2p^1, 1s^2 2s^2 2p^2, 1s^2 2s^2 2p^3, 1s^2 2s^2 2p^4, 1s^2 2s^2 2p^5, 1s^2 2s^2 2p^6$$

The electron configurations can be used to explain the periodic table. The periodic table is an arrangement of the elements according to their properties. The periodic table is periodic in a sense that similar properties repeat as the principal quantum number increases. It is not periodic in a sense that similar properties repeat in equal intervals. The properties of the elements depend on the highest energy subshell (the last subshell in the electron configuration) and the number of electrons in this subshell. When the elements are grouped in such a way that elements with the same highest energy subshell and the same number of electrons in their highest energy subshell are grouped together, the result is the periodic table of the elements. For example the elements, Hydrogen, Lithium, Sodium, Potassium, Rubidium, Cesium and Francium are grouped together in the periodic table because they all have an s-subshell with one electron as their highest energy subshell or last subshell in their electron configuration.

12.4 PRACTICE QUIZ 12

Choose the best answer. Answers can be found at the back of the book.

1. According to the Rutherford model of the atom
 - A. The atom is a positively charged mesh with electrons embedded in it uniformly.
 - B. The negative component of the atom is concentrated at a very small part of the atom with positive charges revolving around it.
 - C. The positive component of the atom is concentrated at a very small part of the atom with electrons revolving around it.
 - D. The atom cannot be decomposed into smaller components.
 - E. The positive component of the atom is concentrated at a very small part of the atom surrounded by a cloud of negative charges.
2. Calculate the radius of the fifth orbit of the hydrogen atom
 - A. $6.75e-15$ m
 - B. $7.8e-11$ m
 - C. $4.6e-8$ m
 - D. $2.65e-10$ m
 - E. $1.3e-9$ m

3. Calculate the energy of an electron in the fourth orbit
- A. -0.85 eV
 - B. -5 eV
 - C. -217 eV
 - D. -3.4 eV
 - E. -54.4 eV
4. Calculate the frequency of the light emitted when an electron drops from the orbit to the second orbit.
- A. $5e14 \text{ Hz}$
 - B. $6.563e-7 \text{ Hz}$
 - C. $1.52e6 \text{ Hz}$
 - D. $4.57e14 \text{ Hz}$
 - E. $6.5e14 \text{ Hz}$

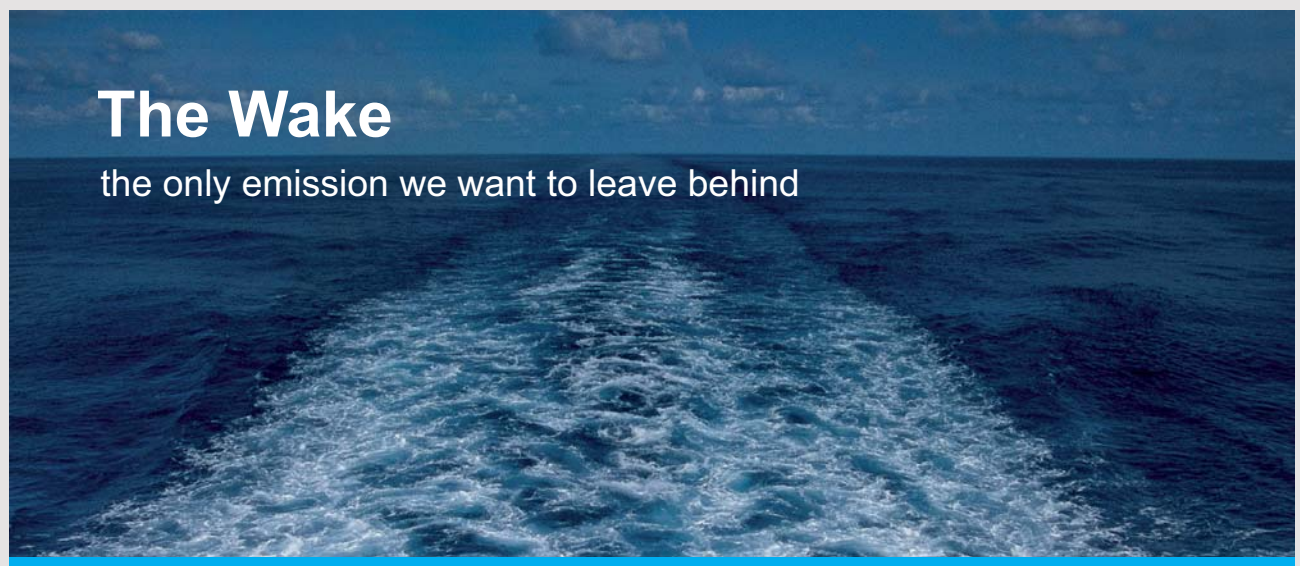

The Wake

the only emission we want to leave behind

Low-speed Engines Medium-speed Engines Turbochargers Propellers Propulsion Packages PrimeServ

The design of eco-friendly marine power and propulsion solutions is crucial for MAN Diesel & Turbo. Power competencies are offered with the world's largest engine programme – having outputs spanning from 450 to 87,220 kW per engine. Get up front! Find out more at www.mandieselturbo.com

Engineering the Future – since 1758.

MAN Diesel & Turbo



5. What is the maximum number of electrons that can be accommodated in a d subshell
 - A. 6
 - B. 2
 - C. 10
 - D. 8
 - E. 14

6. What is the maximum number of electrons that can be accommodated in the fourth energy level (shell)
 - A. 50
 - B. 32
 - C. 16
 - D. 8
 - E. 18

7. Write the electron configuration of an element whose atomic number is 25 and determine the number of electrons in its highest energy subshell
 - A. 2
 - B. 8
 - C. 4
 - D. 5
 - E. 1

13 NUCLEAR PHYSICS

Your goals for the chapter are to learn about the nucleus of the atom, radio activity, binding energy, and nuclear reactions.

The nucleus as the positively charged component of the atom occupying a very small volume of the atom, was discovered by Rutherford. The radiation (alpha particles) that Rutherford used to bombard a gold foil which enabled him to discover the nucleus was actually radiation emitted by a nucleus. This radiation was discovered earlier by Becquerel and is known as radio activity. Later it was discovered that the nucleus is made of two kinds of particles known as a proton and a neutron. The proton has a mass of about 1837 times the mass of the electron. The proton is positively charged with a charge numerically equal to that of the electron ($1.6e-19$ C). The neutron has about the same mass as a proton and does not have a charge. The number of protons of an atom is called the atomic number of the atom. The sum of the number of protons and number of neutrons of an atom is called the mass number of the atom. Since the atom is neutral, the number of electrons is equal to the number of protons. In nuclear physics an element whose atomic number is Z and whose mass number is A is symbolically represented as ${}_A X^Z$ where X is the chemical symbol of the element. For example the symbol ${}_{23}Na^{11}$ is a representation of sodium atom with atomic number 11 and mass number 23.

The identity of an atom (what makes it a unique element) is determined by its atomic number. Atoms with the same atomic number but different mass number (that is, same number of protons but different number of neutrons) are said to be different isotopes of the same element. When electrons are bombarded into atoms, they will be decelerated because of the electrical force exerted by the nucleus. Because of the deceleration, the electrons emit radiation known as x-rays. Some of these rays called characteristic rays (rays produced when an electron in the inner shell is knocked out), turned out to be finger prints of the element (that is, the characteristic ray was uniquely related with the element being bombarded). The fact that this radiation was also found out to be related uniquely with the atomic number of the element, established the fact that the uniqueness of an element is directly related with its atomic number and not mass number (atomic weight) as previously thought. This realization helped resolve some discrepancies in the periodic table.

13.1 RADIO ACTIVITY

Radio activity is the decay of an atom when its nucleus decays by emitting three kinds of particles spontaneously. These particles are known as alpha, beta and gamma particles. An alpha particle is essentially a doubly charged Helium ion. It consists of two protons and two neutrons. A beta particle is an electron. A gamma particle is a photon. When a nucleus emits an alpha particle, its atomic number decreases by two and its mass number decreases by four (${}_Z X^A \rightarrow {}_{Z-2} Y^{A-4} + {}_2 He^4$). Since this process changes the atomic number, the element is converted into another kind of element. During a beta emission, a neutron becomes a proton and the atomic number increases by one while the mass number remains the same (${}_Z X^A \rightarrow {}_{Z+1} Y^A + e^-$). Since the atomic number changes during this process, the end product will be a different kind of element. A gamma emission occurs when a nucleus falls from an excited state to a lower state. This does not change the atomic or mass number and the element remains the same element (${}_Z X^A \rightarrow {}_Z X^A + \gamma$). Gamma radiation is the most energetic radiation.

SMS from your computer

...Sync'd with your Android phone & number

FREE
30 days trial!

Go to

BrowserTexting.com

and start texting from
your computer!

BrowserTexting

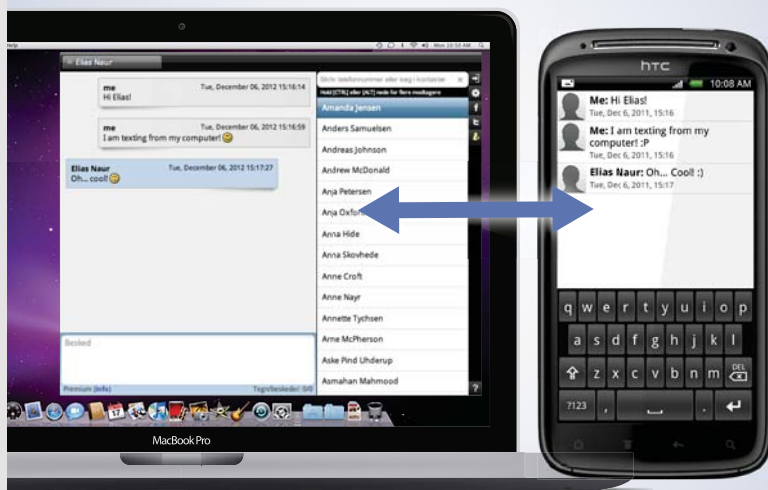

The decay of a radioactive atom by emitting radiation is spontaneous. This means it is impossible to predict whether a certain atom will decay or not at a particular instant of time. But the probability that a certain atom might decay at a given instant of time is a constant for a given radioactive element. As an analogy, consider flipping of a coin. Even though it is impossible to predict whether the outcome will be a head or tail, the probability of getting a head is a constant which is $1/2$. But if a large number of coins are tossed at the same time, it is possible to predict that about half of them will be heads. Similarly, if there are a large number of radioactive atoms, it is possible to predict the fraction of atoms that will decay (which should be equal to the probability) at a given instant of time. Another way of saying this is the number of particles that decay at a given instant of time (decay rate) is proportional to the number of radioactive atoms present. As atoms of a given sample keep decaying, the number of atoms available for radio activity decreases. Using the language of calculus, this relationship may be expressed as $dN/dt = -\lambda N$ where N stands for the number of atoms available for decay at an arbitrary time t ; and λ is a constant called decay constant. The methods of calculus can be used to show that the number of atoms available for decay decreases exponentially with the base being the natural number $e = 2.718$.

$$N = N_0 e^{-\lambda t}$$

Where N_0 is the number of radioactive atoms at $t = 0$. The SI unit of decay rate which is number of decay per second is defined to be the Becquerel, abbreviated as Bq. The time interval during which the number of atoms available for decay decreases to half of the initial number of atoms is called the *half-life* (τ) of the decay: $N_0/2 = N_0 e^{-\lambda \tau}$ or $e^{-\lambda \tau} = 1/2$ or $\lambda \tau = \ln(2)$. Therefore the half-life as a function of the decay constant is given as

$$\tau = \ln(2)/\lambda = 0.693/\lambda$$

Example: ${}_{53}^{132}\text{I}$ has a half-life of 2.3 hours. Initially a sample of this iodine isotope has 2e20 atoms.

- a) Calculate its decay constant.

Solution: $\tau = 2.3 \text{ hr} = 8280 \text{ s}$; $\lambda = ?$

$$\tau = 0.693/\lambda$$

$$\lambda = 0.693/\tau = 0.693/8280 \text{ s}^{-1} = 8.37 \times 10^{-5} \text{ s}^{-1}$$

b) Calculate the number of iodine that have not decayed yet after one day.

Solution: $N_0 = 2e20$; $t = 1 \text{ day} = 86400 \text{ s}$; $N = ?$

$$N = N_0 e^{-\lambda t}$$

$$= 2e20 * e^{-(8.37e-5 * 86400)} = 1.45e17$$

13.2 BINDING ENERGY

As stated above, a nucleus is made up of protons and neutrons. The mass of the protons and neutrons taken as free individual particles is greater than the mass of the nucleus. When protons and neutrons are combined together to form a nucleus, the difference in mass is released as energy according to Einstein's formula $E = mc^2$. This energy is also the amount of energy needed to break the nucleus into its component protons and neutrons and is called the *binding energy* of the nucleus. Suppose a nucleus of a certain element x has mass m_x and contains N_p protons and N_n neutrons. Then the binding energy E_b of the nucleus is given by

$$E_b = (N_p m_p + N_n m_n - m_x) c^2$$

Where $m_p = 1.6726e-27 \text{ kg}$ is the mass of the proton, $m_n = 1.6750e-27 \text{ kg}$ is the mass of the neutron and $c = 3e8 \text{ m/s}$ is the speed of light. A common unit of mass in nuclear physics is the atomic mass unit (u) which is equal to $1.6605e-27 \text{ kg}$. A common unit of energy in nuclear physics is the electron volt (eV) which is equal to $1.6e-19 \text{ J}$.

Example: The mass of an alpha particle is 4.00153 u . Calculate its binding energy in eV.

Solution: An alpha particle has two protons and two neutrons.

$N_p = 2$; $N_n = 2$; $m_\alpha = 4.00153 \text{ u} = 4.00153 * 1.6605e-27 \text{ kg} = 6.6445e-27 \text{ kg}$; $E_b = ?$

$$E_b = (N_p m_p + N_n m_n - m_\alpha) c^2$$

$$= (2 * 1.6726e-27 + 2 * 1.6750e-27 - 6.7446e-27) * 3e8^2 \text{ J}$$

$$= 4.563e-12 \text{ J}$$

$$= 4.563e-12 / 1.6e-19 \text{ eV} = 2.852e7 \text{ eV}$$

13.3 NUCLEAR REACTIONS

A *nuclear reaction* is a process by which two nuclei collide to create different kind of nuclei or nucleus. During a nuclear reaction, in addition to energy and momentum, the atomic number and the mass number should be conserved. That is, the sum of atomic numbers before the reaction should be equal to the sum of atomic numbers after the reaction; and the sum of mass numbers before the reaction should be equal to the sum of mass numbers after the reaction. In other words, the number of protons and neutrons is conserved. Binding energy increases in reactions that release energy and decreased in reactions that absorb energy. A reaction in which energy is released is called *exothermic* reaction. A reaction in which energy is absorbed is called *endothermic* reaction.

A reaction in which two nuclei react to produce a single nucleus is called *fusion*. A reaction in which a nucleus breaks down into smaller nuclei is called *fission*. The binding energy of the nuclei increases as atomic number increases up until atomic number 62. Beyond atomic number 62 the binding energy of the atoms decreases as the atomic number increases. For reactions that release energy involving smaller (below atomic number 62) nuclei, fusion is more likely because bigger nuclei in this range have more binding energy. For reactions that release energy involving heavy (above atomic number 62) nuclei, fission is more likely because smaller nuclei in this range have more binding energy.

**YOUR WORK AT TOMTOM WILL
BE TOUCHED BY MILLIONS.
AROUND THE WORLD. EVERYDAY.**

Join us now on www.TomTom.jobs

follow us on **LinkedIn**



#ACHIEVEMORE

TOMTOM 

Example: When ${}_1H^1$ reacts with ${}_3Li^7$ two atoms were formed. If one of the atoms is ${}_2He^4$, determine the other atom.

Solution: The atomic number and the mass number should be conserved.

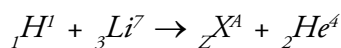

$$1 + 7 = A + 4$$

$$A = 4$$

$$1 + 3 = Z + 2$$

$$Z = 2$$

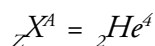

13.4 PRACTICE QUIZ 13

Choose the best answer. Answers can be found at the back of the book.

- Which of the following is an incorrect statement?
 - The binding energy of the elements increases with the increase of atomic number.
 - Fission is a process by which a nucleus breaks down into smaller nuclei.
 - Exothermic reaction is a reaction where energy is released.
 - Atoms with the same atomic number but different mass numbers are said to be isotopes of each other.
 - The radioactive decay rate of a sample is proportional to the number of atoms in the sample.
- When an atom decays by emitting an alpha particle, its mass number
 - decreases by 2
 - remains the same
 - decreases by 4
 - increases by 4
 - increases by 1

3. When an atom decays by emitting a beta particle, its mass number
- A. decreases by 4
 - B. increases by 1
 - C. decreases by 1
 - D. remains the same
 - E. increases by 2
4. When the nucleus of an atom decays by emitting a photon, its atomic number
- A. increases by 1
 - B. decreases by 2
 - C. increases by 1
 - D. remains the same
 - E. decreases by 1
5. The half-life of Carbon (mass number 14) is 5730 years. How long will it take for 90% of a sample of this element to decay?
- A. 12000 years
 - B. 51000 years
 - C. 75000 years
 - D. 19000 years
 - E. 44000 years
6. Calculate the binding energy of oxygen (mass number 16 and atomic number 8). Assume the mass of the nucleus to be the same as the atomic weight of the atom which is 15.9994 u
- A. $1.924e-11$ J
 - B. $2.654e-10$ J
 - C. $4.487e-12$ J
 - D. $6.764e-12$ J
 - E. $5.645e-11$ J

14 ANSWERS TO PRACTICE QUIZZES

Practice Quiz 1.1

1. B 2. D 3. D 4. E 5. C 6. A 7. D 8. E 9. D 10. E

Practice Quiz 1.2

1. A 2. C 3. E 4. C 5. A 6. B 7. C 8. D 9. B 10. C

Practice Quiz 2.1

1. E 2. B 3. D 4. C 5. B 6. E 7. B 8. A 9. E 10. E 11. A 12. B 13. D 14. E

Practice Quiz 2.2

1. E 2. C 3. E 4. D 5. B 6. B 7. E 8. A 9. E 10. A 11. A 12. C

Practice Quiz 3.1

1. A 2. A 3. A 4. C 5. A 6. A 7. D 8. B



Brain power

By 2020, wind could provide one-tenth of our planet's electricity needs. Already today, SKF's innovative know-how is crucial to running a large proportion of the world's wind turbines.

Up to 25 % of the generating costs relate to maintenance. These can be reduced dramatically thanks to our systems for on-line condition monitoring and automatic lubrication. We help make it more economical to create cleaner, cheaper energy out of thin air.

By sharing our experience, expertise, and creativity, industries can boost performance beyond expectations. Therefore we need the best employees who can meet this challenge!

The Power of Knowledge Engineering

Plug into The Power of Knowledge Engineering.
Visit us at www.skf.com/knowledge

SKF

Practice Quiz 3.2

1. C 2. D 3. D 4. E 5. C 6. D 7. B 8. E 9. E 10. B

Practice Quiz 4.1

1. E 2. E 3. A 4. B 5. B 6. D 7. D 8. A 9. D 10. A 11. E 12. C 13. B 14. E

Practice Quiz 4.2

1. C 2. C 3. E 4. A 5. E 6. C 7. C 8. D 9. C 10. E

Practice Quiz 5.1

1. E 2. A 3. D 4. E 5. E 6. A 7. B 8. A 9. B 10. C 11. A

Practice Quiz 5.2

1. C 2. A 3. C 4. B 5. C 6. B 7. D 8. C 9. A 10. B

Practice Quiz 6.1

1. C 2. B 3. D 4. B 5. B 6. D 7. D 8. A 9. B 10. B 11. B 12. E

Practice Quiz 6.2

1. C 2. B 3. B 4. A 5. D 6. E 7. D 8. E 9. B 10. A

Practice Quiz 7.1

1. D 2. B 3. B 4. B 5. B 6. C 7. A 8. A 9. A 10. E

Practice Quiz 7.2

1. D 2. B 3. D 4. A 5. E 6. A 7. B 8. E 9. A 10. B 11. E 12. E

Practice Quiz 8.1

1. C 2. B 3. D 4. A 5. D 6. B 7. A 8. B 9. D 10. D 11. A 12. B 13. A 14. B

Practice Quiz 8.2

1. A 2. B 3. C 4. B 5. C 6. C 7. B 8. B

Practice Quiz 9.1

1. B 2. A 3. C 4. D 5. A 6. E 7. C 8. E 9. B 10. D 11. B 12. A

Practice Quiz 9.2

1. E 2. E 3. D 4. A 5. B 6. A 7. D 8. E 9. C 10. A

Practice Quiz 10

1. C 2. B 3. D 4. D 5. D 6. C

Practice Quiz 11

1. A 2. A 3. E 4. D 5. E 6. E 7. B 8. E

Practice Quiz 12

1. C 2. E 3. A 4. D 5. C 6. B 7. D

Practice Quiz 13

1. A 2. C 3. D 4. D 5. D 6. A



> Apply now

REDEFINE YOUR FUTURE
**AXA GLOBAL GRADUATE
PROGRAM 2015**

redefining / standards 

agence.cdg - © Photonistop