

Dr. Miltiadis A. Boboulos

Manufacturing Processes and Materials: Exercises

Miltiadis A. Boboulos

Manufacturing Processes and Materials: Exercises

Manufacturing Processes and Materials: Exercises

1st edition

© 2010 Miltiadis A. Boboulos & Ventus Publishing ApS & bookboon.com

ISBN 978-87-7681-695-7

Contents

	Summary	7
Question 1	Non-conventional manufacturing processes	8
Question 2	The Electro-discharge Machining (EDM) process	15
Question 3	Factors causing tool wear	21
Question 4	Acceptance sampling	34
Question 5	Principles of the Resin Transfer Moulding (RTM)	48
Question 6	Fibre reinforced plastic composites	52
Question 7	A cutting test on a steel bar	57



Discover the truth at www.deloitte.ca/careers

Deloitte.

© Deloitte & Touche LLP and affiliated entities.



Click on the ad to read more

Question 8	Electro-discharge machining (EDM) requirements & properties	61
Question 9	Hard and soft automation	64
Question 10	Surface integrity of manufactured surfaces: properties & applications	68
Question 11	Bored holes – plug and gap gauges	71
Question 12	Integrated Manufacturing Systems: a facility of large and small machines	76
Question 13	Simulation method, determining the time to complete the batch and the machine utilisation	82
Question 14	Plain carbon steels and high strength low alloy steels (HSLA)	94
Question 15	Ferritic stainless steel & the mechanism of corrosion	98
Question 16	Impact Strength (J) to Test Temperature	103

© 2013 Accenture. All rights reserved.

be > your degree

Bring your talent and passion to a global organization at the forefront of business, technology and innovation. Discover how great you can be.

Visit accenture.com/bookboon

Be greater than.
consulting | technology | outsourcing

accenture
High performance. Delivered.



Question 17	Metal and polymer material applicability	108
Question 18	Maximum tolerable through thickness crack size	112
Question 19	Glass fibres production – Reinforced composite design	117
	References	122
	Endnotes	124

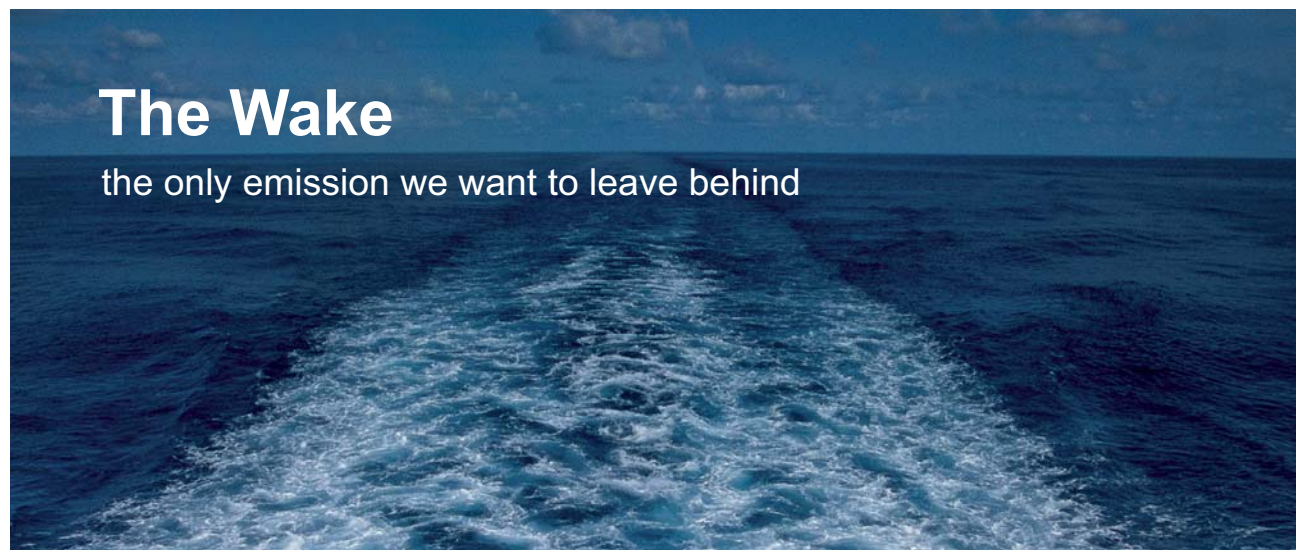

The Wake

the only emission we want to leave behind

[Low-speed Engines](#) [Medium-speed Engines](#) [Turbochargers](#) [Propellers](#) [Propulsion Packages](#) [PrimeServ](#)

The design of eco-friendly marine power and propulsion solutions is crucial for MAN Diesel & Turbo. Power competencies are offered with the world's largest engine programme – having outputs spanning from 450 to 87,220 kW per engine. Get up front!
Find out more at www.mandieselturbo.com

Engineering the Future – since 1758.
MAN Diesel & Turbo



Summary

The edition addresses issues essential to modern manufacturing, ranging from traditional topics such as casting, forming, machining, and joining, to advanced topics such as the fabrication of nanomaterials. Comprehensive coverage of relevant engineering fundamentals, mathematical analysis, and traditional as well as advanced applications of manufacturing processes and operations. This material is written mainly for students in mechanical, industrial, and metallurgical and materials engineering programs. The text continually emphasizes the important interactions among a wide variety of technical disciplines and the economics of manufacturing operations. A solid introduction to the fundamentals of manufacturing along with the most up-to-date information. In order to make the concepts easier to understand, a variety of engineering materials are discussed as well as their properties and means of modifying them. Manufacturing processes and the concepts dealing with producing quality products are also covered.

Question 1 Non-conventional manufacturing processes

You are a Manufacturing Engineer employed by a toolmaking company whose main business is in sub-contract manufacture of a wide range of tools used in the injection moulding and forging industries. There is also a specialist division machining small batches of precision components for the aerospace industry. Component workpiece materials include most toolsteels, high duty alloys and a range of sintered materials, non-ferrous materials stainless steels and ceramics. The existing manufacturing facility include all the usual conventional machine tools including a number of stand alone CNC multi-tool machining centres.

Your Managing Director, through his trade association and by glancing through technical journals is aware that competitors of the company are introducing non-conventional manufacturing processes to their facilities.

You have been requested to submit a brief report covering the following issues:

- a) What is meant by the term non-conventional manufacturing processes?
[2 Marks]
- b) What are the areas of application of such processes?
[8 Marks]
- c) How do non-conventional processes compare with the companies existing process facilities in respect to:
Feature capability, surface finish, surface integrity, material removal rate, tool wear, environmental issues and skill requirements.
[12 Marks]
- d) What particular non-conventional process might be suitable for the companies current product portfolio?
[3 Marks]

Question 1a

Conventional and wide spread machining processes include: mechanical cutting operations, material removal techniques – chipping off, forging, casting, stamping, engraving. Additionally, conventional processes include turning, milling, drilling, grinding etc. mechanical operations. Back in the 1940s the needs of the defense industry, aviation and space industry, electronics and other industries necessitated machining techniques to be adopted for processing thin, fragile or special and very thin products that could not be manufactured using the conventional processes or this would have been rather impractical and costly. Therefore, a new group of “non-conventional” manufacturing processes emerged to provide improved, convenient and economically advantageous means for specific types of production. These were based on latest scientific and technical achievements and some new findings for using laws of nature relating to light – lasers, sound – ultrasonic processes, magnetism, atomic physics – plasma, electronics and new “powder” metallurgy materials.

Non-conventional processes include:

- a) Chemical machining (CM)
- b) Electrochemical machining (ECM)
- c) Electrochemical grinding (ECG)
- d) Electrical discharge machining (EDM)
- e) Wire electrical discharge machining (WEDM)
- f) Laser-beam machining (LBM)
- g) Electron-beam machining (EBM)
- h) Water-jet machining (WJM)
- i) Abrasive water-jet machining (AWJM)
- j) Abrasive-jet machining (AJM) (using air, sand or beads)

Additionally, we could include here Ultrasonic machining (UM) and Deburring processes.

Example: A typical non-conventional process is the machining of abrasive discs using diamond (adopted in 1955) or synthetic tools – cubic boron carbide (1970). In some applications these processes replaced almost completely the aluminium oxide processes (1893) and the green silicon carbide processes (1891). Other non-conventional processes include powder metallurgy processes used to produce hard-alloy cutting tools made of tungsten carbide, titanium carbide, cobalt carbide, etc.

Question 1 b

The areas of application of non-conventional manufacturing processes are as follows:

- a) Chemical machining (CM): This is used for removing a layer of metal material, either shallow or deep, by means of etching using chemical compounds, like acids, bases, etc. This is a comparatively old process and it has several options: 1. chemical milling, 2. chemical blanking and 3. photo-chemical machining. **Chemical milling** is usually applied where larger quantities of material is to be removed from large plates or panels in the aircraft industry, space industry or cutting in depths of up to 12 mm. The process is used to make large aluminium alloy, etc. plates and sheet-metal parts lighter. **Chemical blanking** is used for manufacturing various scales, dials, rulers, etc. in the instrument-making industry and fine mechanical engineering industry as well as for manufacturing a variety of thin component parts in the mechanical engineering industry. The **photo-chemical blanking** is applied for manufacturing printed circuit boards for the electronic industry, electrical wiring, electronic chip sets and very thin component parts (depths of up to 0.0025 mm) for the aero-space industry, optics, microelectronics, instrument-making industry, printing industry, crafts – engraving metal or other material articles.
- b) Electrochemical machining (ECM): This is based on “dissolving” ions of the processed material (metal) in the area around the tool, which is the electrode (-) of the DC source and the processed part is the (+), the ions thus being removed from the conductive electrolyte. This is used in wide machining applications for high-alloyed rigid steels and materials and also for manufacturing complex cutting shapes – turbine propellers, tools – stamps, moulds, dies. The technique is suitable for drilling small holes and cutting into hard materials
- c) Electrochemical grinding (ECG): This process is a combination between ECM and a conventional grinding machine. The difference is in the electrical insulation provided in the machine spindle and grinding wheel and the use of an electrolyte instead of a coolant. The tool – the grinding wheel is the (-) of the electrical source and the part being machined is the (+). The technique is applied in machining carbide tools and alloy tools, carbide steel parts, etc. alloys featuring high strength characteristics. Used for grinding, milling and drilling small holes. Not suitable for manufacturing dies
- d) Electrical discharge machining (EDM): This is a widely applied and very useful method based on the erosion of metals caused by the discharge occurring between the electrode and the processed part. The technique is applied for manufacturing tools and dies – for machining cavities and contour shaping and cutting. Used to cut and machine very hard and hardened conductor materials. Could find application in various machine engineering fields, etc. Also applied in automated processes involving CNC machining centers. Used to manufacture complex dies, for example for extrusion of aluminium component parts, etc.
- e) Wire electrical discharge machining (WEDM): This is an optional EDM technique where the electrode is a continuous wire, which is used to cut the metal material similar to a band saw. Used for contour cutting of flat or curved surfaces – Figure 1.

The depth of the cutting plates is adjustable to up to 300mm. The tool (the wire) is usually made of copper, brass or tungsten and of outside diameter 0.25mm.

Another optional EDM technique is the **electrical discharge grinding** where a conventional internal grinding machine is used the grinding stone of which is a conductor material (brass, graphite) playing the role of the electrode and the part being machined is any conductor material. Mostly used for grinding hard carbide alloys of titanium, tungsten, cobalt and tool steels; for machining fragile and brittle small-size components, surgical tools, optical devices, electronic devices, etc.

- f) Laser-beam machining (LBM) is used for similar applications to those stated above – cutting, drilling, marking and for surface machining and welding operations involving various materials: metals, ceramics, plastics, leather, textiles, composite materials (in the aircraft industry, etc.).
- g) Electron-beam (plasma) machining (EBM) is used in similar applications to those described for LBM but performed in a vacuum surrounding medium: precise cutting and welding of various materials.
- h) Water-jet machining (WJM): This technique is used for dynamic cutting and machining various materials: plastic, rubber, foodstuffs, paper, leather, insulation materials, composite materials of up to 25mm thickness. Finds application in the food industry and the production of plastics.
- i) Abrasive water-jet machining (AWJM): for “shooting” under pressure and applying dynamic action to the surface of the machined component part. Used for the same applications and materials as those described for WJM.
- j) Abrasive jet(gas) machining (AJM): Applied for machining small holes, cleaning surfaces from removing sand or scale in foundry applications, stamped forgings and also for non-metal and fragile materials, as well as for deburring operations.

Question 1c

As described in paragraph 1b above, machining operations feature similar or various spheres and sites of application. Non-conventional manufacturing processes are applied where conventional methods are not applicable, such as cutting and machining very hard, fragile, brittle or small-size component parts.

1. Based on the particular characteristics of the process we can select the most suitable technique for each specific application. For example, cutting the internal cavity of an average-sized temperature treated high-hardness die is usually slow and expensive when using conventional machining techniques. A suitable non-conventional process for such an application is the EDM method. We select the suitable method based on the material hardness, brittleness, part size and material type. If we have to cut thick steel plates along an external contour that could be of a complicated shape the suitable method is the WEDM process. For drilling and welding various materials we select the LBM method and for drilling holes of outside diameter smaller than 0.1 – an operation which is almost impossible to perform using conventional techniques- the EDM or ECG process.

Machining rough or corroded (oxidized) external surfaces is best performed using the AJM manufacturing process.

2. Quality comparison: Several quality characteristics are important here and these include surface roughness (Ra), dimensional tolerances, structure of the material in the cutting area. To examine these parameters we use data from tables, graphs, formulae and process studies.

For example, these include the Roughness (Ra)/ process type relation charts as shown in Figure 2 and the tolerance/process type relation chart, as well as the average and extreme repetition probabilities for their values.

3. Comparison based on structure: Some manufacturing processes, like for example the LBM and EBM result in distortions of internal material structure in the cutting area, so other techniques are to be preferred when this is not desirable, such as CM or ECM, EDG and EDM.

SMS from your computer
...Sync'd with your Android phone & number

FREE
30 days trial!

Go to
BrowserTexting.com

and start texting from
your computer!

BrowserTexting

4. Process efficiency comparison (material removal rate comparison) (MRR): This is based on the data and formulae used to calculate the quantity of removed material (metal chips) per unit time of operation. For example, for EDM the material removal rate $MRR = 4 \times 10^{-4} I T_w^{-1.23}$ [mm³/min]. This equation points out the major factors that influence the MRR rate – the current I (A) and electrode wear T_w . It is a known fact for this particular process that increasing the current I and reducing the discharge frequency (number of discharges per second) [Hz] will reduce process efficiency (material removal rate). For the ECG process the material removal rate $MRR = CI\eta/A_0$, where in this particular case C is a constant value which depends on the type of machined material (values for C are taken from tables – for Al $C=2.0$; for Cu $C=4.4$, for Fe...) These expressions could be used to evaluate, compare and draw conclusions on the value of energy used in the process and hence, estimate **process efficiency**.
5. Tool wear [R]. We will discuss this factor separately and as an integral part of the factors used to judge for the suitable manufacturing process. Here again we use available data and formulae to make calculations. Hence, for EDM $R = 2.25 T_r^{-2.3}$, where $T_r = T_w / T_E$; T_w is the melting temperature of the material and T_E is the melting temperature of the electrode (tool). Using copper, graphite or tungsten electrodes can extend tool life but would result in different tool cost. We can estimate tool consumption for a certain period based on tool wear and eventually estimate the efficiency of the selected process also considering the MRR rate.
6. Environmental considerations: It is important to assess the environmental impact of the process. Processes like EDM, which involve machining in a kerosene fluid, de-ionized water, etc. do not normally emit harmful substances into the atmosphere and are a preferred selection from an environmental viewpoint compared, for example, to laser-beam machining or other **thermal** metal cutting techniques.

The LBM method could be very dangerous to operators as it might cause radiation and harmful fumes. The AJM should by all means be used with protective clothing for operators or air-tight automated chambers. The process emits dust and flying “damaging” metal particles, etc. It is necessary that the machines in most of the described processes are equipped with the required air filters, settlement sedimentations and air conditioning systems.

7. Personnel skills: To be able to compare and select the most suitable non-conventional process it is important to give consideration to the required personnel skills available in the company. Described machining processes generally require higher qualification and more costly labour. This is even more important when CNC-control machining centers are used. Some of the processes could also employ low-skilled operators but training cost and labour safety measures will be involved here.

Conclusion: A more precise and correct selection, assessment and comparison of the processes could be made using the table describing the general process characteristics – Appendix 1.

Question 1d

The current average-size toolmaking range of the company can preferably employ any conventional equipment and techniques used for this type of production along with the EDM, WEDM, AJM, ECG and ECM non-conventional manufacturing processes. The production of more complicated small-size component parts for the aerospace industry should preferably employ the EBM. LBM, EDM, ECM and EDG manufacturing processes. A precise estimate of process efficiency should be made when selecting the suitable type of process taking into account relatively expensive machines and equipment involved in the EDM, LBM, EBM, etc. processes.

**YOUR WORK AT TOMTOM WILL
BE TOUCHED BY MILLIONS.
AROUND THE WORLD. EVERYDAY.**

Join us now on www.TomTom.jobs

follow us on **LinkedIn**



#ACHIEVEMORE

TOMTOM 



Question 2 The Electro-discharge Machining (EDM) process

- a) The Electro-discharge Machining (EDM) process is widely used in the toolmaking industry. In this context discuss the advantages and the disadvantages of the die sinking EDM process.

[14 marks]

- b) With the aid of an annotated sketch illustrate a typical EDM single voltage pulse, indicating voltage levels and timescales. Explain why a characteristic pulse has this profile.

[6 marks]

- c) (Explain the principles and features of the “orbital technique” as applied to the EDM process.

[5 marks]

Question 2 a

When applying the EDM manufacturing process the workpiece is machined either “sunk” into a specific fluid or not, the fluid which covers the workpiece in the cutting area being a dielectric.

The method which involves die-sinking uses a work table specifically made airtight (a sinking bath where the fluid is provided). The type of fluid most widely used is kerosene (petrol), distilled water or deionized water. This arrangement of the application of the EDM manufacturing process provides for the electrical discharge between the tool [electrode (-)] and the cathode (+), which in fact is the machined workpiece, to take place in dielectric fluid medium. The method features the following advantages and disadvantages:

2a 1 Advantages:

1. The fact that the process takes place in a fluid medium improves the removal of metal chips from the cutting area and enhances cooling characteristics of the tool and workpiece.
2. Improved cooling and fast discharge resulting from switching off of the electrical impulse (frequency between 50 and 500 KHz) improves the wear resistance of the electrode (tool) and improves surface integrity (Ra) of the machined surface.
3. Due to the electrical discharge the process eliminates almost completely the emission of harmful gases into the atmosphere.
4. The process allows for “heavy” duty operation in higher frequency and current (A) values which results in increased process efficiency.

2a 2 Disadvantages:

1. The presence of a work table, a bath tank, requires longer servicing time and impedes the process. When the workpiece is to be positioned onto the work table the tank has to be emptied of the contained fluid and the same happens when the machined part is to be removed from the work table.
2. Above requirements bring certain inconvenience during operation and involve higher energy consumption for filling in and pumping out the fluid from the tank. The machine itself becomes more complex in design and more expensive as it requires to be equipped with suitably designed units.
3. Removal of metal chips could in some cases be provided when machining blind holes such that chips are accumulated at the bottom of the vertical tool feed.
4. The presence of a large quantity of fluid, kerosene, in the machine in the operational area is a fire hazard. Special fire and explosion protection measures will be required for the machine and personnel.
5. When the WEDM method is to be applied for cutting operations the entire machine will be much more complicated requiring additional sealing for the wire (the electrode).
6. Applying the EDM method for turning lathes, grinding machines, etc. having horizontal work axis is not very easy as is the case for EDG (Electrical discharge grinding).
7. Applying the “orbital” processing technique is rather difficult.
8. The process provides poor visibility over the machined part for the operator to observe the process.
9. Item 8 above results in using mostly CNC control machines and equipment, which are in turn more complicated and expensive to use.

Question 2b

1. Corona and spark discharge

This type of discharge process occurs when a relatively high pressure is available and electrodes are featured by very high non-uniformity of the discharge area (gap). Ionization takes place only in a thin layer around the electrode characterized by a small radius of the curve. This is called an ionizing layer. In real practice these are “corona” cylindrical wires. When DC voltage is supplied, a negative (-) or positive (+) corona is available depending on the polarity of the corona electrode. As the voltage on the corona electrode increases, the corona undergoes **arch** discharge or **spark** discharge (when the source output power is insufficient to maintain **stationary** arch discharge – constant electrical arch.* When a positive corona is applied spark discharge occurs at lower voltage (U) compared to negative corona. The temperature of the gas in the spark “channel” reaches 10000°K. This allows for thermal ionization to occur. This phenomenon does not fall within the category of the theory of the “avalanche”- type of discharge and is explained by the theory of “streamers”.

The **first condition** for the formation of “streamers” is the following:

$$(1) \frac{a}{p} e^{\frac{a}{p}pd} = 2,19 \cdot 10^8 \frac{E_3}{p} \left(\frac{a}{pd} \right)^{\frac{1}{2}} d$$

where a – coefficient of volumetric ionization [M^{-1}];

p – gas pressure [Pa]

d – distance between electrodes

E_3 – voltage in the area between electrodes [V/m].

From (1) we can conclude $U_3 = E_3 d$ (2),

Where U_3 is the voltage required for a spark to occur [V], and

E_3 is the voltage in the area between electrodes [V/m].

Thus calculated, the voltage U_3 is exactly identical with experimental data measured at $p \cdot d > 250$ [MPa].

The **second condition** for streamer formation is:

$$(3) n_1 \geq 7 \cdot 10^{20} \text{ [ions/m}^3\text{]},$$

where: n_1 is the concentration of ions in the avalanche head.

The condition (3) refers to relatively short spark gaps (times) and is always met when (1) is met as well.

Study case 1:

Calculate drilling voltage between flat electrodes in air medium at $p = 10^5$ [Pa] (760mm mercury column) and $T = 293^\circ\text{K}$ (20°C):

- for $d = 1$ cm (0.01m) $U_3 = 31.35$ [kV]
- for $d = 2$ cm (0.02m) $U_3 = 58.10$ [kV]

2. Diagram of voltage pulse

According to (2) above the diagram of a single voltage pulse is as follows:

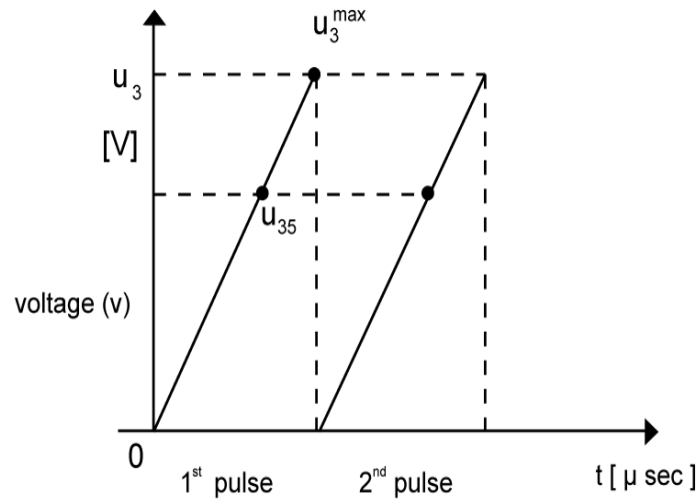

Figure 1

Where U_{35} is the voltage of spark occurrence (electrical discharge)

U_3^{\max} is the voltage of spark extinction (electrical discharge).

While the spark is present between U_{35} and U_3^{\max} , the initial gap “d” between the electrode and the workpiece increases as a result of the **erosion** to d_1 and $d_1 > d$, which results in interruption of the electrical arch (electrical discharge). For a pre-set value of d a constant U_3^{\max} is maintained by the DC voltage. Above condition results from equation (2) since this is a linear relation proportional to the distance between electrodes. From * above we can conclude that process efficiency can increase if we change the polarity of electrodes.

If we assume that U_3 rises from 0 to U_{35} without any time loss the voltage pulse will then look as shown in Figure 2(a) or 2(b), where ΔT is the time required to move the electrode.

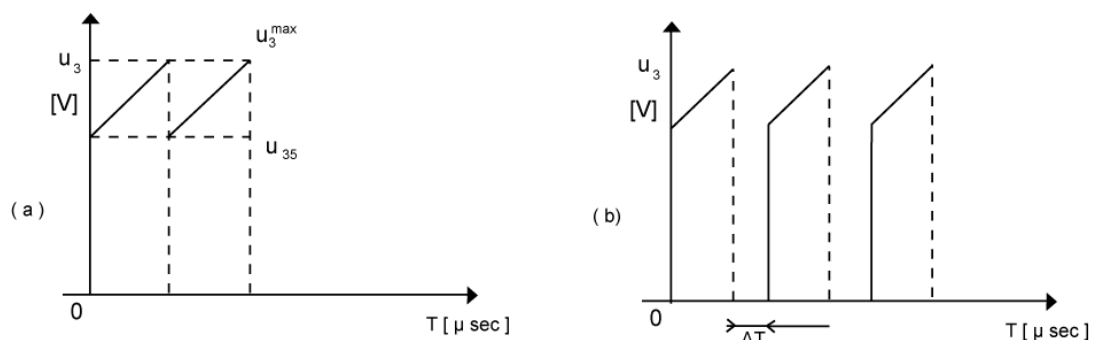

Figure 2

Question 2 c

2 c 1. Features of the “orbital” technique

The “orbital” technique is applied to the EDM process for the forging of some component parts, dies, etc. tooling. This reduces the stress between the tool (the die) and the component part in the contact area thus increasing tool life. Moreover, smaller size (diameter) tools could be used to machine larger cavities or holes of a shape which is completely different from the shape of the die. Moreover, the tool moves in an “orbital” manner, rotating around a certain axis with its operational end or at the beginning of its length, performing a movement similar to the orbital path of planets. (Figure 1).

The figure shows the principal drawing of the die, which “swings” similar to a flywheel around the axis O, such that O_1 in its upper end moves along a circumference (ellipse, etc.), i.e. performs an “orbital” movement. Moreover, the flat radius R forms the recess of an $OD = D$, the forces required to press the material of the workpiece in the area around points M being smaller that what would be required if the entire area $S = \pi.D^2/4$ was to be pressed by a single stroke of the die without the “orbital” movement. The “orbital” technique is applied not only to the EDM process, but also to the ECM process, etc.



Brain power

By 2020, wind could provide one-tenth of our planet's electricity needs. Already today, SKF's innovative know-how is crucial to running a large proportion of the world's wind turbines.

Up to 25 % of the generating costs relate to maintenance. These can be reduced dramatically thanks to our systems for on-line condition monitoring and automatic lubrication. We help make it more economical to create cleaner, cheaper energy out of thin air.

By sharing our experience, expertise, and creativity, industries can boost performance beyond expectations. Therefore we need the best employees who can meet this challenge!

The Power of Knowledge Engineering

Plug into The Power of Knowledge Engineering.
Visit us at www.skf.com/knowledge

SKF

2 c 2. Applying the “orbital” technique to the EDM process

The “orbital” technique is applied to the EDM manufacturing process with the tool, the electrode (-), performing a similar movement to the described in Figure 1 above. An example of one such application is illustrated in Figure 2.

Figure 2

1. Tool holder
 - 1.1 Tool (electrode)
2. Workpiece (round grinding machine)
3. Machine chuck

Let us consider an application of the EDM process for a machine featuring horizontal spindle and chuck 3 used to support the workpiece to be machined, with the holder 1 feeding the tool 1.1 along the X direction, the feeding of the tool resulting in gradual change of the angle α from 0° to α° . The workpiece 2 rotates around X – X with the chuck 3. This results in shaping (cutting) the cavity of an OD = D, having the shape of a pear. Different cutting shapes can be achieved through synchronizing the movement of the workpiece, tool and tool feed.

The “orbital” movement of the electrode can also be applied to conventional machines of vertical tool axis and die-sinking. This will require the rotational movement of the spindle of the machine to provide for the “orbital” movement in point O_1 (operational end) of the electrode. The workpiece can alternatively be fixed to the machine worktable. Thus, smaller size (diameter) electrode could be used to cut or grind larger-size cavities or holes of shapes which are completely different from the cylindrical shape, as well as toroid-shaped, etc. cavities – Figure 3.

Question 3 Factors causing tool wear

- a) In conventional metal cutting process tool wear is inevitable. Discuss the most significant factors that cause tool wear and explain why cutting tool failure is difficult to predict. [8 marks]
- b) Describe four different methods that might be used for the on-line monitoring of tool wear, indicating the possible problems associated with each method and justify the method that you consider to show the most promise. [12 marks]
- c) A steel ring outside diameter 600mm and an internal diameter of 200mm is being faced on a vertical CNC lathe. The machine is capable of maintaining a constant surface speed, as the face of the ring is being machined and the feedrate is set to 0.25 mm/rev. From tests when $v = 50\text{m/min}$ Tool Life T is 60 mins $n = 0.3$. Given Taylor's empirical tool life relationship $VT = C$. Determine the number of components that can be machined per tool for a tool life of 50 mins. [5 marks]

Question 3a

1. Tool wear – causes and significant factors

1.1 Introduction

When processing metals using **cutting tools**, which is usually accompanied by chipping (sometimes no chipping is involved), tools wear and get damaged. Worn tools are usually re-sharpened for re-use or replaced when unrecoverably damaged.

The causes for this phenomenon are various and result from the nature of the different machining processes involved (metal cutting, alloy cutting, cutting other types of material) and also from all other subjective factors involved and influencing the process.

Processing, i.e. cutting conditions usually involve significant energy consumption, occurrence of substantial forces, vibrations, shocks and emission of heat. In this sense, cutting conditions are heavy processing conditions and therefore lead to faster tool wear or damage especially when hard, tough and high-strength materials are to be processed or when high-speed processing or fast-feed processing aimed at increasing production efficiency is involved.

1.2 Causes and significant factors

Generally, causes for cutting tool wear or damage are cutting edge wear or the occurrence of obvious breaking out on cutting edges or internal cracking and stress. These are determined by the extent of applied pressure and slipping of metal chips as well as the nature of surface being machined. Included in the cumulative load is also the tool temperature in the area where the load is applied. Tool temperature usually rises due to the heat Q emitted during the processing (cutting) operation.

$$Q = \frac{P_z \cdot V}{427} [\text{ccal/min}] \quad (1)$$

where Q is the emitted heat; P_z is the shear force [dN] and V is the cutting speed [m/min].

Although **cutting speed** is an independent variable, the forces and temperatures generated are dependent variables and are functions of numerous parameters. Similarly, **wear** depends on tool and workpiece materials (their physical, mechanical and chemical properties, tool geometry, cutting fluid properties and various other operating parameters). The types of wear on a tool depends on the relative roles of these variables. Due to the complicated relations and numerous factors influencing tool wear, various experimental methods and data is usually used to define the type of wear.

Let us consider, for example, tool wear on a conventional lathe knife – figure 1.

> **Apply now**

REDEFINE YOUR FUTURE
**AXA GLOBAL GRADUATE
PROGRAM 2015**

redefining / standards 

agence.cdg. © Photonistop

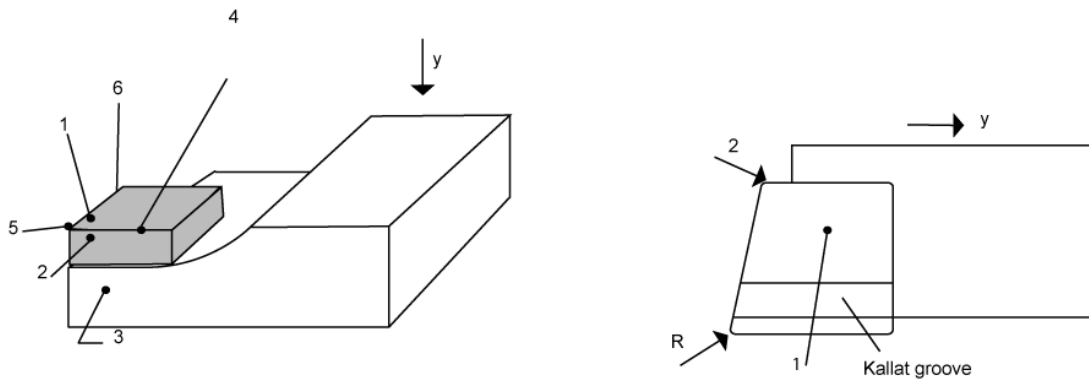

Key:

1. Front face
2. Rake face
3. Flank face
4. Cutting edge
5. Tool tip
6. Auxiliary cutting edge

Considering the geometry and characteristic elements of a lathe knife, tool wear usually occurs in indicated significant cutting edges and faces along with unrecoverable breaking (damage) with significant breaking out of the cutting tool and internally observed and hidden cracking. In other words, tool wear results in the tool being **incapable** to continue the process carried out between the machine, tool and workpiece (due to different tool size, surface integrity, internal structure, etc.). The term “tool life” is used to identify the time period until the tool is made **incapable to perform** its functions.

The most significant types of wear are crater wear and flank wear, as well as tool tip and cutting edge breaking out and cracking. These types of wear occur in different ways for different tool materials – figure 2 (for example, carbides, high-speed steels, ceramics, diamond, etc.)

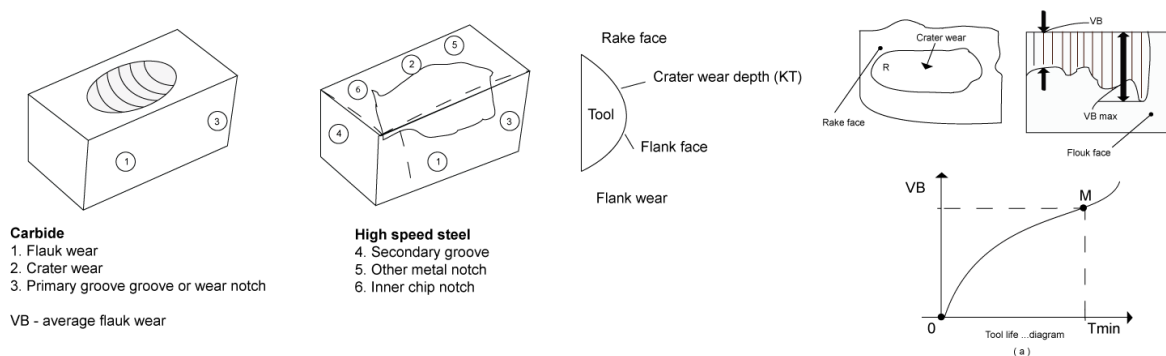

Figure 2

Key:

1. Flank wear
2. Crater wear
3. Primary groove or wear notch
4. Secondary groove
5. Other metal chip notch
6. Inner chip notch
7. VB – average flank wear.

Tool life is as illustrated in Figure 2: (a) – the tool is within the normal required process parameters between points O and M. Following point M, KT and VB have reached the allowable limit.

Wear usually refers to gradually increasing wear without any visible scratching and furrowing, and **damage** is usually referred to **notching** with breaking off of particles from cutting edges. The ratio of occurrence of the two types of wear in a particular type of processing operation depends on **load conditions** at the tool-workpiece interface. In ceramics, for example, plates and tools operating under vibration and used to machine fire-resistant and alloy steels usually break off along their cutting edges. Apart from normal tool wear (flank wear) there are a number of other factors that influence tool wear: insufficient tool strength characteristics and available internal cracks. When the applied pressure (as a result of P_2) exceeds the ultimate strength limit this results in sudden breaking off along the cutting edge. **High speeds** and temperatures cause **diffusion** – interpenetration and rubbing of tool-workpiece materials. **Friction** causes abrasive and adhesive wear. To summarize, the most significant factors include:

- Cutting conditions: speed, feed, cooling, geometry
- Tool and workpiece materials (physical and mechanical properties, chemical composition, inclusions, density, etc.)
- The characteristics of the machine-tool-workpiece system (stability, output, etc.)
- Other factors – operator, qualification, processing technology.

Since cutting speed is among the most significant factors determining tool life (T), it is usually calculated using Taylor's relation:

$$VT^n = C \quad (2),$$

Where V is the cutting speed [m/min], T is time [min] and n is a constant value which depends on cutting conditions and C is a constant value.

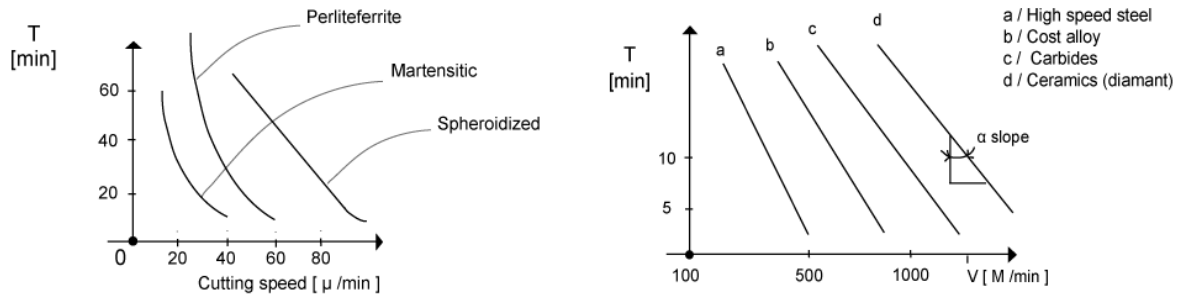

Figure 3

Above expression is a synthesized relationship between a number of factors that influence wear. From the diagrams illustrated in figure 3 we can observe how T is influenced by V depending on tool-workpiece materials.

LIGS University

based in Hawaii, USA

is currently enrolling in the
Interactive Online **BBA, MBA, MSc,**
DBA and PhD programs:

- ▶ enroll **by October 31st, 2014** and
- ▶ **save up to 11%** on the tuition!
- ▶ pay in 10 installments / 2 years
- ▶ Interactive **Online** education
- ▶ visit www.ligsuniversity.com to find out more!

Note: LIGS University is not accredited by any nationally recognized accrediting agency listed by the US Secretary of Education. More info [here](http://www.ligsuniversity.com).





∞

Workpiece material

Tool material

- a) High-speed steel
- b) Cast alloy
- c) Carbides
- d) Ceramic (diamond)

α - the slope angle: determines the value of “n”

It is obvious here that tool life increases when the speed V is reduced and the hardness and toughness of the material being processed are reduced, too. If we apply the expression (2) we can **calculate** that under certain conditions (fixed n and C), tool life T increases by 300% when V [m/min] is reduced by only 50%. It is a proven fact that for a constant tool life to be maintained, the speed is reduced when the feed f and the depth d are increased and vice versa.

1.3 Difficulties in forecasting (predicting) tool wear

All explained above makes it clear why it is so hard and sometimes even impossible to give precise forecast for tool life. It is not always possible to predict the influence that numerous factors and their combinations may have. If we take, for example, the expression for P_z (shear force) given above

$$P_z = C_{pz} t^{X_{pz}} S^{Y_{pz}} HB^{pz} \cdot k_m \cdot k_\phi \cdot k_r \cdot k_j \cdot k_h \quad (3)$$

where the following parameters are included: feed, cutting depth, hardness and a number of experimentally determined coefficients... up to k_h , thus illustrating the complexity of the problem. If we assume that the **main factor** influencing tool life “T” is the applied **load** expressed by the applied **forces, temperature** (heat), **shocks, vibrations**, then the applied load is in turn influenced by:

- the cutting conditions: speed, feed, depth, cooling, type of processing
- material type: Al, Fe..., size, geometry, quality: porosity, abrasive inclusions, oxides
- the machine-tool-workpiece system: stability, power, vibration resistance characteristics, type
- tool type and characteristics: ceramics, Figure 4: A machine-tool-workpiece system
- high-speed steels, carbides; geometry, shape, angles, grooves, chipping, etc.
- cooling: intensity, coolant type
- other factors: operator, operator’s faults, low qualification, processing technique (incorrect processing technology).

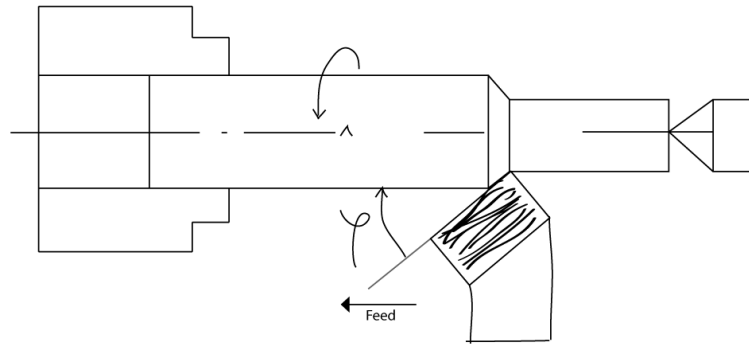

Figure 4: A machine-tool-workpiece system

When cutting long workpieces the change in the angle φ on the tool holder can sometimes cause **unexpected** vibrations, tool **wear** or **breaking off** due to operator's fault (poor qualification).

The complexity of the problem can also be demonstrated using the expression for

$$T = C^7 V^7 d^{-1} f^4.$$

Question 3 b

Monitoring the condition of tools throughout various machining processes is very important for any production process and has significant influence on process efficiency. This is usually performed in two ways: a) Directly and b) Indirectly

- a) The **direct method** involves **visual** observation by the operator for any signs of wear, wear hardening (getting dull) or breaking off. It usually requires the operator to stop the machine to dismantle and replace the worn tool. This method of monitoring tool condition involves visual observation or examining under special microscope for some out-of-service adjustment.
- b) The **indirect method** uses indirect information to monitor the condition of the tool: noise, vibrations, size of machined workpiece, shear forces, surface roughness, etc. This is a relatively new method, convenient for CNC machines and is used to assess the condition of the tool "on-line" within the process.

1. Method of monitoring tool wear based on measured forces, vibration and deformations

The method is based on the principle of measuring the value or the change of the shear force P_z , vibration amplitude or frequency and deformation observed in the machine-tool-workpiece system to monitor the condition of the cutting tool – Figure 1.

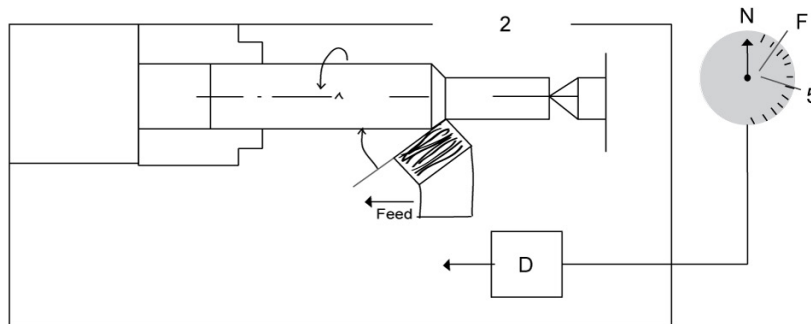

Key to Figure 1:

1. Machine
2. Workpiece
3. Tool positioned in tool holder
4. Sensor
5. Indicator

TURN TO THE EXPERTS FOR **SUBSCRIBE** CONSULTANCY

Subscribe is one of the leading companies in Europe when it comes to innovation and business development within subscription businesses.

We innovate new subscription business models or improve existing ones. We do business reviews of existing subscription businesses and we develop acquisition and retention strategies.

Learn more at [linkedin.com/company/subscribe](https://www.linkedin.com/company/subscribe) or contact Managing Director Morten Suhr Hansen at mha@subscribe.dk

SUBSCRIBE - to the future

The sensor 4, a piezoelectric transducer (crystal) senses deformations, a rotation of the tool holder around the point O, and sends a signal to the indicator 5. When the arrow moves beyond point F the machine stops automatically and this is an indication of a worn-out or broken tool.

1.2 Advantages

This is a convenient and easily applicable method. The sensor 4 can be mounted on the tool holder or on a number of other locations or assemblies: the spindle, tailstock, lathe bed, etc. In these positions we can measure the value of torsion, deflection, etc. resulting from cutting forces and momentums.

1.3 Disadvantages

Requires additionally rather complex electrical equipment to be installed and it is not always convenient to mount since it requires additional space on the machine and additional electrical connections. This is rather inconvenient for moving operational parts of the machine, such as the carriage, tailstock, etc.

1. Monitoring tool condition based on the level of noise and vibrations – the acoustic method

The relation between the amount of main types of wear and noise level during operation are monitored here – figure 2.

The method is very similar to the described above in para. 1 in the way of its application. In this case the piezoelectric transducer senses the noise signal, the cutting sound, and transforms it into an electrical pulse the level of which is monitored by the indicator 5 (Figure 1) and sends a signal to the CNC control whenever set limits are exceeded to stop the machine and a “warning” alarm signal to the operator.

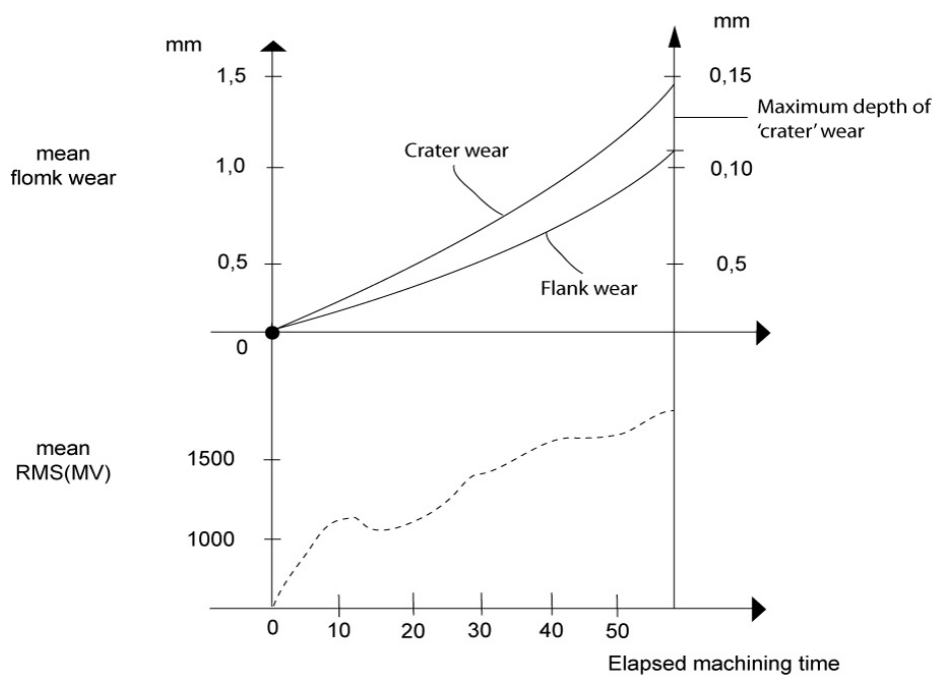

2.1 Advantages

The monitoring device and the equipment it involves can be positioned outside the machine, far from moving machine parts.

2.2 Disadvantages

- Here, again special equipment and hardware is required to connect the device to the CNC control.
- Not all materials and cutting conditions allow for monitoring wear based on noise level.

3. Pneumatic method

This is an older method very often used in serial and mass production. The condition of the tool is monitored based on the size of machined workpiece. The principle of the method is based on measuring the “gap” between a compressed air (or other type of fluid) nozzle and the machined surface, monitoring the pressure in the system (the volume of air being discharged) – figure 3. The volume (quantity) of discharged air is used to monitor the size [μm] of the gap between the nozzle and the machined surface of the workpiece 2. When the indication goes beyond point F on the indicator 5 the system sends electrical indication to the machine controls and signals the operator.

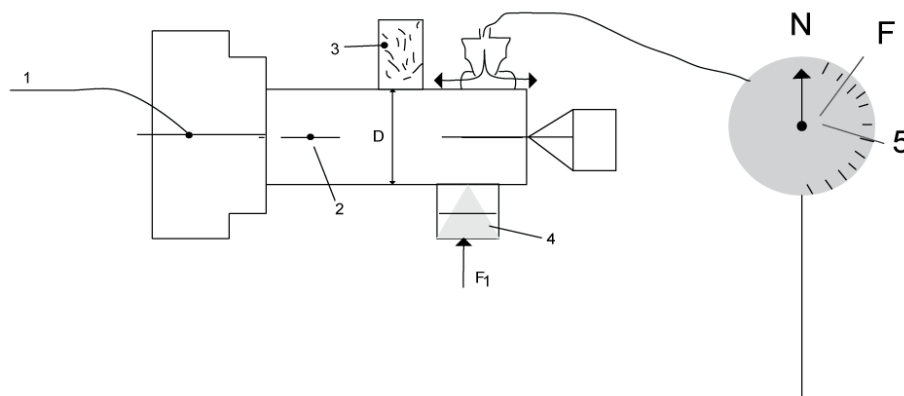

3.1 Advantages

This is a widely used and relatively inexpensive method for a number of grinding and other machines used in serial and mass production. Also useful for measuring during screening – reels, metal beads, etc.

3.2 Disadvantages

- The method involves fairly complicated arrangement of devices and larger units.
- Compressed air (fluid) installation connections are required. The method is not applicable to small-scale serial production and for the production of different product shapes and sizes. Additionally, the method is influenced by metal chips clogging the nozzle.

4. Tool “touch” sensing method

This is applied mostly for automated machines and recently, for CNC-control machining centres. It is very close to the “direct” sensing method (tool tip or cutting edge) or uses a microscope connected to the electronic controls of the machine. A command in the machine CNC control is issued to the tool to move towards the sensor, which touches the tool to read if it is still **good**, **worn out** or **broken**. The sensor send an electronic signal to the CNC control of the machine and signals the operator for the failure so he can dismantle or re-sharpen and replace the cutting tool.

4.1 Advantages

Widely applied and suitable for machining centres and CNC-control machines.

4.2 Disadvantages

- This method does not provide for monitoring tool condition all the time.
- Data accuracy is influenced by metal chips and other types of contamination.
- Monitoring more complicated types of tools is fairly difficult to perform.
- (In some cases) the method requires operation time.
- Involves relatively expensive and complex equipment.



“I studied English for 16 years but...
...I finally learned to speak it in just six lessons”
Jane, Chinese architect

ENGLISH OUT THERE

Click to hear me talking before and after my unique course download

5. Selection

Considering all described above the most suitable method for universal machines, such as lathes, milling machines, etc. is method No1 and the most suitable method for machining centres and CNC-controlled machines is method No.4.

Question 3 c

Given $V = 50$ [m/min]; $T = 60$ [min] and $n = 0.3$ and using Taylor's relationship $V.T^n = C$, we can calculate $C = 50 \cdot 60^{0.3}$ $\lg 50 + 0.3 \lg 60 = \lg C$
or $\lg C = 1.69897 + 0.3 \cdot 1.778 = 2.2324$

$$C = 170.77148$$

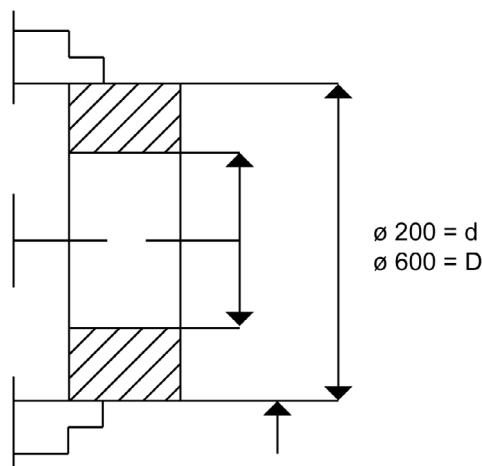

From Figure 1 we calculate: $\frac{\phi 600 - \phi 200}{2} = \left(\frac{D - d}{2} \right) = 200[\text{mm}] = S$

At a feedrate of $t = 0.25$ [mm/rev] we will need:

$n_1 = \frac{S}{t}$ revolutions of the spindle (workpiece) to be able to machine the face of the ring (figure 1),

and $t = 0.25$ [mm/rev].

$$n_1 = \frac{200}{0.25} = 800 \text{ [rev].}$$

Since according to the initial assignment the cutting speed is constant $V_c = \text{const.}$, then from Taylor's $V.T^n = C$ and for $T = 50$ [min] we will have:

$$V \cdot 50^{0.3} = 170.77148$$

$$V = 52.81 \text{ [m/min]}$$

The path of the tool between ϕ 600mm and ϕ 200 mm is:

$$S_1 = \int_D^d \pi \cdot D \cdot n_1 \cdot d_d$$

$$S_1 = \pi(D - d)n_1 =$$

$$3.14(600 - 200) \cdot 800 =$$

$$1004.8[m]$$

The time T_1 required for a single workpiece to be machined by the tool is:

$$T_1 = \frac{S_1}{V} = \frac{1004.8}{52.81} = 19.0266 \text{ min}$$

The number of components that can be machined is

$$N = \frac{T}{T_1} = \frac{50}{19.02} = 2.62 \text{ components.}$$

wethrive.net

How to retain your top staff

FIND OUT NOW FOR FREE

DO YOU WANT TO KNOW:

- What your staff really want?
- The top issues troubling them?
- How to make staff assessments work for you & them, painlessly?

Get your free trial

Because happy staff get more done



Question 4 Acceptance sampling

Question 4a

Acceptance sampling is often viewed to be at odds with a TQM (Total Quality Management) philosophy.

Why is acceptance sampling still in use by many companies and how might it conflict with the goals of a “world class” operation?

1. Introduction

Lot-by-lot acceptance sampling by attributes is the most common type of sampling. With this type of sampling a predetermined number of units (samples) from each **lot** is inspected by attributes. If the amount defective is less than the prescribed minimum, the lot is accepted, if not, it is rejected as being below standard. Each lot in the shipment or order is sampled and either rejected or accepted. **Acceptance sampling can be used either for the amount defective or for defects per unit.** Sampling plans are established for each class of **defect severity** (critical, major, minor) or on a demerit-per-unit basis. A single sampling plan is defined by the lot size N , the sample size n and the acceptance number c . (**Example:** $N = 5000$, $n = 250$, $c = 20$. 20 in 250 are defectives). **Acceptance sampling can be performed in a number of different situations where there is a consumer-producer relationship.**

2. Why is Acceptance Sampling (AS) widely used by manufacturing companies and other organizations?

The basic and most significant reason is the fact that the method can be applied in a variety of situations related to quality management, complying with contractual terms, preventing unexpected situations, etc. Moreover, it delivers **results or conclusions of sufficient accuracy** for a wide variety of purposes.

The method is applied in situations where:

* The inspection results in damage or destruction to the product. If instead of this method (AS) a 100% inspection is applied, this will destroy the **entire** amount of finished produce. **Example:** Inspection of batches of ammunitions (cartridges, shells, etc.) or melting electrical fuses (for 10A)[J].

- Since 100% inspection of products would involve additional cost this would add to the cost of the final products (quality control inspections are included in the cost of the product).
- When a **large variety** of **similar** products have to be inspected (a wide product range based on a single type of product or principle) sampling will produce as good, if not better results than 100% inspection. Such **mass** inspections cause **fatigue to quality control personnel due to the monotonous work** which might in turn result in more errors than the average accepted percentage when using the Sampling acceptance method.
- When the \bar{x} and R and p indicators are not provided in the information relating to quality – no diagrams are available (Pareto chart, etc.)
- When no automated means of control are provided and products are inspected manually or visually.

Besides all said above, the AS method has the following additional advantages compared to 100% inspection:

1. It is less costly owing to fewer inspections
2. Less handling damage during inspection
3. Fewer inspectors are involved, thereby simplifying recruiting, training and supervising.
4. Upgrading the inspection job from monotonous piece-by-piece decisions to lot-by-lot decisions.
5. Rejection of entire lots, rather than the return of defectives, thereby providing stronger motivation for improvement.

3. How might Acceptance sampling conflict with the goals of “World-class” operations.

Besides all listed in para 2 above preferences and advantages in adopting the acceptance sampling method in practice for many companies and organizations (industry, trade, transport, etc.), the method also features several **disadvantages**. These might, in particular situations, make it unsuitable or completely unfit to use. Inherent disadvantages of AS are:

- There are certain risks of accepting defective lots and rejecting good lots.
- More time and effort is devoted to planning and documentation.
- Less information is usually provided about the product

If we consider, for example some specialized and high-tech manufacturing processes, space and aviation, aerospace industry, microelectronics and all applications where requirements and responsibilities for defective components and products are much higher, AS is not an applicable method. In such applications very strict 100% inspection is usually performed on each individual component, parameter or event. For an aircraft engine, for example, the quality of component parts, parameters, assembly and functioning must be checked more than a single time. In some cases, multiple inspections and tests have to be carried out to prove the required quality and fitness for the purpose. Also, in the production of bearings, the production of balls, rollers, bearing rings involves 100% automated control and ranking in size and class. The same inspection is also involved in the production of a number of elements for the electronics – integrated circuit boards, chips, standard electronic component, etc.

- In developing sampling plans and Operating characteristics (OC) it is possible that in some cases characteristics and diagrams do not provide a clear idea and satisfactory results when errors have occurred in specific indicators, such as lot size N , n , c , etc.

gaiTeye[®]
Challenge the way we run

**EXPERIENCE THE POWER OF
FULL ENGAGEMENT...**

.....

**RUN FASTER.
RUN LONGER..
RUN EASIER...**

**READ MORE & PRE-ORDER TODAY
WWW.GAITEYE.COM**

The advertisement features a runner in a red shirt and black leggings on a dirt path at sunset. Technical diagrams, including a dotted line and a circle with lines, are overlaid on the runner's path.

In view of all described above we should exercise great care when adopting the Acceptance sampling method for inspecting (and forecasting) the quality of production, transportation, services, trade and many other fields of application keeping in mind the allowable requirements and acceptable risk of losses and consequences. AS might in some cases lead to conflicts between manufacturers (suppliers) and users (customers). The producer is usually looking for lower possible rejection of manufactured products even when there is a high percentage of defective products in individual lots and the buyer (customer) has the opposite interest – higher possibility for not having defective goods above the agreed percentage and even have reduced percentage of defectives.

Question 4b

The ACME packing company produces plastic bottles for the Kooler company, a soft drink manufacturer. Kooler have specified an acceptable quality level (AQL) of 1% and a tolerance proportion defective (LTPD) of 6%.

If a batch (5000 bottles) is rejected then all the bottles in the batch are scrapped and consequently the producer’s risk (α) be no more than 2%. In this case the consumers’ risk (β) has been specified as 4%.

- i. Design a sampling plan for the above conditions by determination of the required sample size and the acceptable maximum number of defectives in each batch.

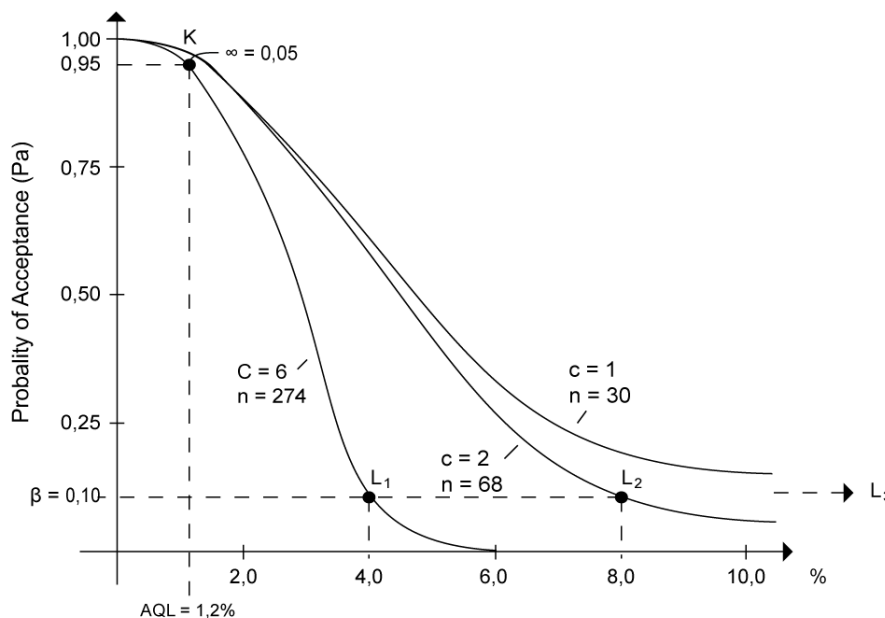

Task (b) defines $AQL = 1\%$ and $LTPD$ of 6% , where **AQL** is an acceptable proportion of defects in a batch to the consumer, and **LTPD** is the maximum number of defective items a consumer will accept in a batch.

Producer's risk is the probability of rejecting a batch that is within the AQL [α] – to be illustrated on the x axis of the diagram [Pa] as a coefficient].

Consumer's risk is the probability of accepting a batch in which defectives exceeds the LTPD [β] – illustrated on the y axis [Pa] as a coefficient].

When the producer's risk α and its corresponding acceptable quality level (AQL) are specified, a **sampling plan or a family S.Plans can be determined. For example:** for a producer's risk of $\alpha = 0.05$ and an AQL = 1.2% the OC (Operational curve) for a family of sampling plans are obtained – **Figure 1.**

Illustrated in the figure is a Single sampling plan for stipulated producer's risk and AQL.

All three curves cross point K (for $\alpha = 0.05$ and an AQL = 1.2%) but have different points for L_1 L_2 L_3 for LQL.

Each of the plans passes through the point defined by $Pa = 0.95$ ($\alpha = 0.05$) and $P_{0.95} = 0.012$ ($0.012 \times 100 = 1.2\%$). Therefore, each of the plans will ensure that product 1.2% defective will be rejected 5% (of the time), or, conversely, accepted 95% (of the time).

The sampling plans are obtained by assuming a value for “c” and finding its corresponding “np₀” value from Table C.

Table C shows the values for Pa relative to c and np₀ calculated using the Poisson formula:

$$P_{(d)} = \frac{n!}{d!(n-d)!} p_0^d q_0^{n-d} \quad (1)$$

where $P_{(0)} = P_{(d)}$ is the probability for rejects (d); n is the number of units in the sample; α is the number of rejected components (events) from all “ n ” (defectives); p_0 is fraction defective in the population, q_0 is fraction good ($1 - p_0$) in the population / or $c = d$.

Then knowing np_0 and p_0 , the **Sample Size “n” is obtained.** To eliminate the interpolation operation, np_0 values for $\alpha = 0.05$ and $\beta = 0.10$ are reproduced in Table 1. in this table, “C” is **cumulative**, which means that a C value of 2 represents 2 or less. We also use Table 1 since it provides C values for np and a typical risk for the producer and consumer.

Table 1 (6-4) np values for corresponding C values and typical producer's and consumer's risk:

C	$P_a = 0.95$ ($\alpha = 0.05$)	$P_a = 0.10$ ($\beta = 0.10$)	Ratio of $P_{0.10} / P_{0.95}$
0	0.051	2.303	44.890
1	0.355	3.890	10.946
2	←0.818	←5.322	←6.509
3	←1.366	←6.681	←4.890
4	1.970	7.994	4.057
5	2.613	9.275	3.549
6	3.286	10.532	3.206
7	3.981	11.771	2.957
8	4.695	12.995	2.768
9	5.426	14.206	2.618
10	6.169	15.407	2.497
11	6.924	16.598	2.397
12	7.690	17.782	2.312
13	8.464	18.958	2.240
14	9.246	20.128	2.177
15	10.035	←21.292	←2.122

Table 1

This e-book
is made with
SetaPDF



SETASIGN



PDF components for PHP developers

www.setasign.com



“ n ” for the three Sampling plans (as illustrated in Figure 1) is calculated as:

for $c = 1$; $np_{0.95} = 0.355$ (Table[6 – 4]); $Pa = 0.95$; $p_{0.95} = 0.012$

$$\text{or } n = \frac{n \cdot p_{0.95}}{p_{0.95}} = \frac{0.355}{0.012} = 29.6 (\approx 30), \text{ etc. for } c = 2.$$

For the first task condition in the task $LTPD = 6\%$ and $AQL = 1\%$ ($LTPD = LQL$). Since the producer’s risk and customer’s risk is set in advance, 4 plans are available that satisfy both the producer (2 off) and the consumer (2 off). It is difficult to obtain an OC curve that will satisfy both conditions – Figure 2 (6-20 page 211).

The two curves crossing point K satisfy the producer for $\alpha = 0.05$; 0.9% defective – AQL and the two curves (shown in dotted lines) through point L satisfy the buyer for $7.8\% = LQL$ and $\beta = 0.10$.

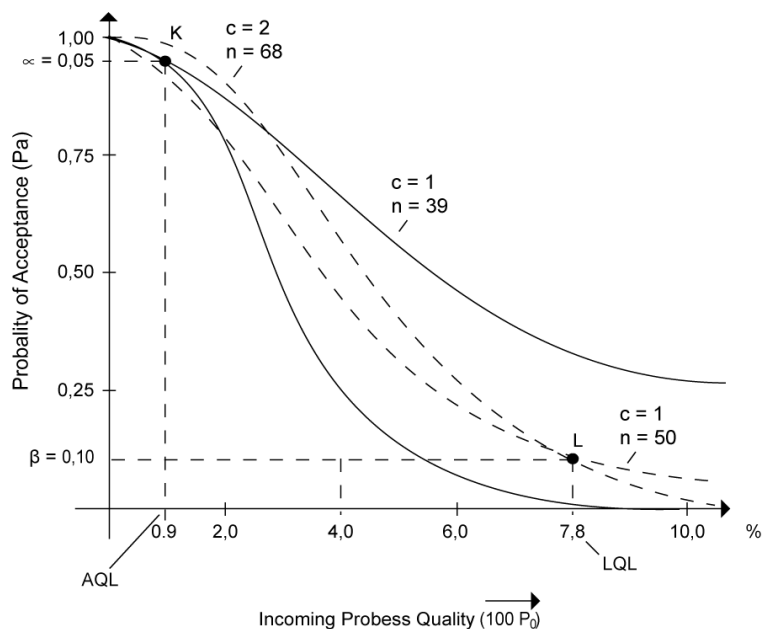

Since we are interested in satisfying the interests of both the **producer** and **customer**, we use the following expressions:

$$\frac{P_{0.10}}{P_{0.95}} = \frac{LQL(LTPD)}{AQL} = \frac{0.06}{0.01} = 6.00 \quad (2)$$

From Table 1 (6-4), which is **recommended** for use as α (AQL) varies between 0.01 and 0.10 (0.15), which is sufficient in most cases, we select

$$\frac{P_{0.10}}{P_{0.95}} (\text{Ratio}) = 6.509$$

which corresponds to $c = 2$ (closer to $c = 2$) but is between: 4.890 and 6.509, or $4.890 < 6.00 < 6.509$, where 4.890 is for $c = 3$. We can now make up 2×2 plans OC for the producer using $c = 2$ and 3 and for the consumer, with $c = 2, 3$.

- We now calculate “ n ” for every $c(2,3)$: (n = sample size):

a) for the producer:

$$\text{For } c = 2 \quad n = \frac{np_{0.95}}{p_{0.95}} \quad (3)$$

$$p_{0.95} = 0.01 \text{ (1\%)}$$

$$n p_{0.95} = 0.818 \text{ (para 6-4)}$$

- Plans that exactly meet the producer’s stipulation of AQL = 1% (for $\alpha = 0.05$)

$$\text{From (3)} \quad n_2 = \frac{0.818}{0.01} = 81.8 \approx 82[\text{pcs}]$$

$$\text{For } c = 3 \quad n_3 = \frac{1.366}{0.01} = 136.6 \approx 137[\text{pcs}]$$

$$n p_{0.95} = 1.366 \text{ [from para 6-4]}$$

$$N = 5000; n_2 = 82; c = 2; N = 5000; n_3 = 137; c = 3$$

- Plans that exactly meet the consumer’s stipulation of LTPD = 6% (for $\beta = 0.10$):

$$\text{For } c = 2 \quad n = \frac{np_{0.10}}{p_{0.10}} \quad (4)$$

$$np_{0.10} = 5.322 \text{ (for } c = 2)$$

$$n p_{0.10} = 6.681 \text{ (for } c = 3) \text{ [from table 1(6-4)]}$$

$$\text{From (4)} \quad n_2 = \frac{5.322}{0.06} = 88.7 \approx 89[\text{pcs}]$$

$$p_{0.10} = 0.06 \text{ (according to the initial requirement)}$$

$$\text{For } c = 3 \quad n_2 = \frac{6.681}{0.06} = 111.3 \approx 111[\text{pcs}]$$

$$N = 5000; n_2 = 89; c = 2; N = 5000; n_3 = 111; c = 3$$

For the second task: (α) AQL \leq 2%; (β) LTDP \leq 4%;

Similar to above we can calculate:

$$\text{From (2)} \quad \frac{\text{LTPD}}{\text{AQL}} = \frac{4}{2} \left(\text{or } : \frac{0.04}{0.02} \right) = 2.00 \rightarrow$$

\rightarrow From Table 1 (6-4) we calculate $2.122 > 2.00 > \dots$; $c = 15$

For $c = 15$... **for the producer:**

$$n = \frac{np_{0.95}}{p_{0.95}}$$

$$np_{0.95} = 10.035 \text{ (para 1)}$$

$$p_{0.95} = 0.02 \text{ (2\%)}$$

$$\rightarrow n = \frac{10.035}{0.02} = 501.75 \approx 502[\text{pcs}]$$

For $c = 15$... **for the consumer:**

$$n = \frac{21.292}{0.04} = 532.3 \approx 532[\text{pcs}]$$

$$np_{0.10} = 21.292 \text{ (para 1)}$$

$$p_{0.10} = 0.04 \text{ (4\%)}$$

Maximum number of defectives in the batches (Cn) is:



Discover the truth at www.deloitte.ca/careers

Deloitte.

© Deloitte & Touche LLP and affiliated entities.



Click on the ad to read more

1. For AQL = 1% LTPD = 6% $Cn_1 = N \cdot \text{LTPD} (5)$
2. For AQL = 2% LTPD = 4% $Cn_1 = 5000 \cdot 6\% = 300$ [pcs]
 $Cn_2 = 5000 \cdot 4\% = 200$ [pcs]

Question 4 b (ii)

Draw the “Operating Characteristic” [OC] curve for the inspection station and determine the probability that the batch with 3% defective will be rejected.

1. Assessment of the particular sampling plan

Operating characteristic (OC) is an excellent technique for this purpose. It is desirable to know the probability (P_a) that a lot submitted with a certain percent defective, $100p_0$ will be accepted or rejected. The OC curve will provide this information.

2. Designing the OC curve

We have a single sampling plan available with set parameters and for this particular case we assume $N = 5000$ (lot size), a sampling size of $n = 210$ and an acceptance number $c = 2$. Additionally, we have the condition of 5% defectives. It is assumed that the lots are from a steady stream of product which can be considered infinite and therefore the **binominal probability distribution** can be used for the probability calculations. We use the Poisson’s equation. In graphing the curve with variables: P_a (probability of acceptance) and $100p_0$ (percent defective), one value $100p_0$ will be assumed and the other calculated. Acceptance of the lot is based on the acceptance number $c = 2$ and is possible when there is 0, 1, 2 defectives in the sample. For 3% defectives:

$$np_0 = 210 \cdot 0,03 = 6.30 \cdot 3\% = 0.03$$

$$P_a = P(0) + P(1) + P(2) = 0.052 \text{ (From Table “C” for 6.30).}$$

The value 0.052 is too close to 0 and the curve is asymmetrically inclined towards the X axis.

We draw up the Table 3: $N = 5000$, $n = 210$, $c = 2$

Item	Assumed process quality		Sample size <i>n</i>	<i>np</i> ₀	Probability of acceptance <i>P</i> _a (along the Y axis)
	<i>P</i> ₀ (along axis X)	100 <i>p</i> ₀ (%)			
1	0.002	0.2(%)	210	0.42	0.993
2	0.004	0.4	210	0.84	0.946
3	0.006	0.6	210	1.26	0.866
4	0.008	0.8	210	1.68	0.778
5	0.010	1.0	210	2.10	0.650
6	0.020	2.0	210	4.20	0.210
7	0.030	3.0	210	6.30	0.052
8	0.040	4.0	210	8.40	0.010
9	0.050	5.0	210	10.50	0.002
10	0.060	6.0	210	12.60	0.00

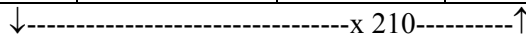
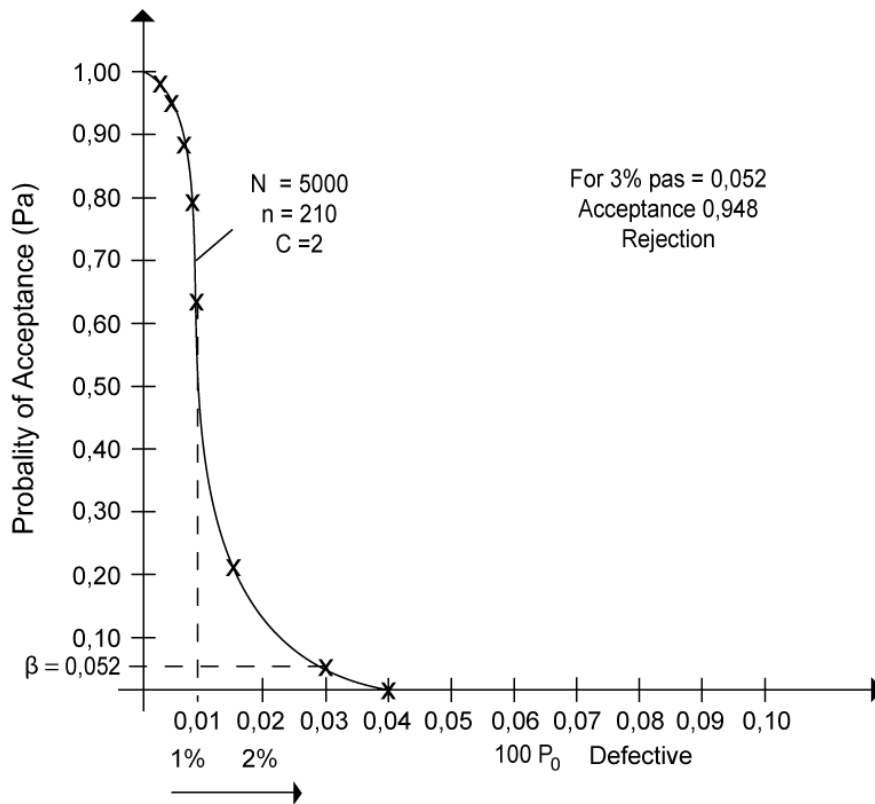

Table 3

Based on the data provided in Table 3 above we can draw the OC curve – Figure 4.



For 3% $P_{a3} = 0.052$ Acceptance 0.948 Rejection

Supplement to Question 4 b (ii)

Graphing OC using AQL = 3%

The initial condition set for AQL is = 3%. We assume a lot size of 5000 and $c = 3$. From the equation (3) and Table 1 (6-4) we can determine the sample size “n”. The OC characteristic for $\alpha = 0.05$ and $\beta = 0.10$ e widely applicable for these values. It most fully satisfies the requirements of the producer (supplier) and the consumer when it is closest to the vertical straight line or is steeper than the abscissa.

$$\text{From (2) } \frac{p_{0.10}}{p_{0.95}} = \frac{\text{LTPD}}{\text{AQL}} = 4.890 \text{ [from table 1 (6-4)]}$$

For $c = 3$ LTPD = $4.890 \times 3 = 14.670\%$ for AQL = 3% and $P_{0.95} = 0.030 = 3\%$

$$\text{From (3) } n = \frac{np_{0.95}}{p_{0.95}} = \frac{1.366}{0.03} = 45.53 \text{ for } np_{0.95} = 1.366 \text{ (from Table 1).}$$

$$n = 46.$$

To draw the “Operating Characteristics” (OC) curve, we calculate graph coordinates using “n” (Pa along the Y axis and $p_{0.100} = \%$ defective along the X axis).

© 2013 Accenture. All rights reserved.

be > your degree

Bring your talent and passion to a global organization at the forefront of business, technology and innovation. Discover how great you can be.

Visit accenture.com/bookboon

Be greater than.
consulting | technology | outsourcing

accenture
High performance. Delivered.



Click on the ad to read more

Proportion defective (P) (X axis)-100p ₀		n . p for n = 46	Probability Pa (Y axis)	Values from Table C	np ₀
1	0.01=(1%)	0.46	0.999	0.999	0.40
2	0.02=(2%)	0.92	0.985	0.999 0.999 0.987	0.50 0.90
3	0.03...	1.38	0.949	0.981 0.957	1.00 1.30
4	0.04...	1.84	0.885	0.947 0.892	1.40 1.80
5	0.05...	2.30	0.799	0.875	1.90
6	0.06...	2.76	0.701	0.799	2.30
7	0.07...	3.22	0.598	0.715	2.70
8	0.08...	3.68	0.499	0.692	2.80
9	0.09...	4.14	0.406	0.603	3.20
10	0.10...	4.60	0.325	0.582	3.30
12	0.12...	5.52	0.205	0.515	3.60
14	0.147...	6.76	0.098	0.494	3.70
				0.414	4.10
				0.395	4.20
				0.325	4.60
				0.265	5.00
				0.151	6.00
				0.151	6.00
				0.081	7.00

↓-----x 46 ↑

Table 2

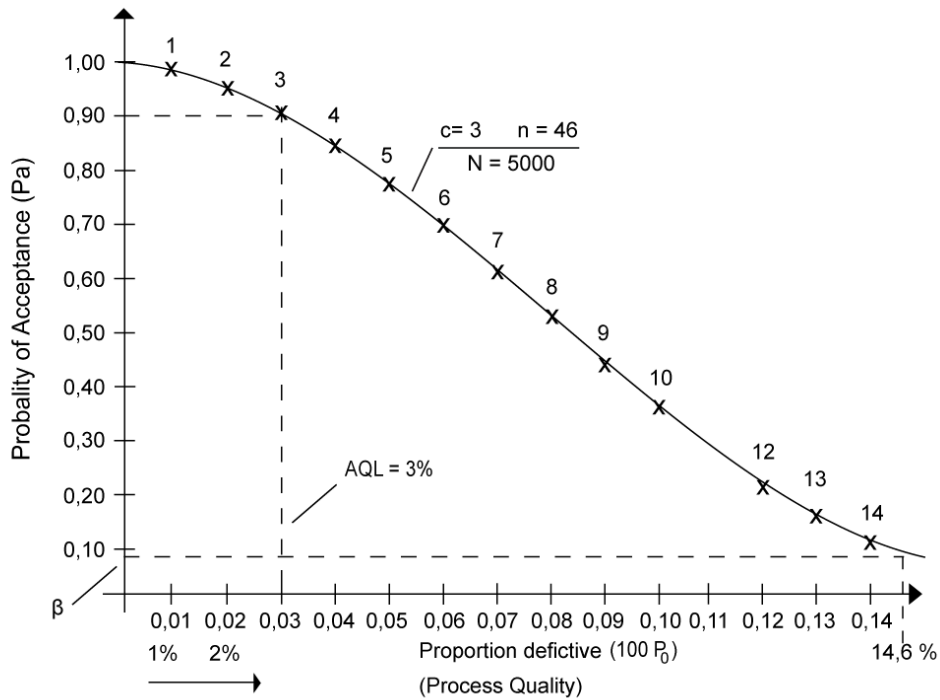

Summary to Question 4b(i) – Figure 2

When selecting the sample size (Question 4 b (i)) we observe 4 additional criteria:

- The first additional criterion is the stipulation that the plan with the lowest sample size be selected. Thus, for the example (i), only the two plans for $c = 1$ are calculated, and $c = 1$, $n = 39$ is selected (Figure 2).
- A second additional criterion – the plan with the greatest sample size be selected ($c = 2$, $n = 91$, Figure2)
- A third additional criterion is the stipulation that the plan exactly meets the consumer's stipulation and comes as close as possible to the producer's stipulation ($c = 1$, $n = 50$ and $c = 2$, $n = 68$) For $c = 1$, $n = 50$, $p_{0.95} = 0.007$. For $c = 2$, $n = 68$, $p_{0.95} = 0.012$. Since 0.007 is closest to the stipulated value of 0.009, the plan of $c = 1$ and $n = 50$ is selected.
- The fourth additional criterion for the selection of one of the four sampling plans is the stipulation that the plan exactly meets the producer's stipulation and comes as close as possible to the consumer's stipulation. The two plans that are applicable are: $c = 1$, $n = 39$ and $c = 2$, $n = 91$. For $c = 1$, $n = 39$ $p_{0.10} = 0.100$. For $c = 2$, $n = 91$ $p_{0.10} = 0.058$. Since $p_{0.10} = 0.058$ is closest to the stipulated value of 0.078, the plan of $c = 2$, $n = 91$ is selected.

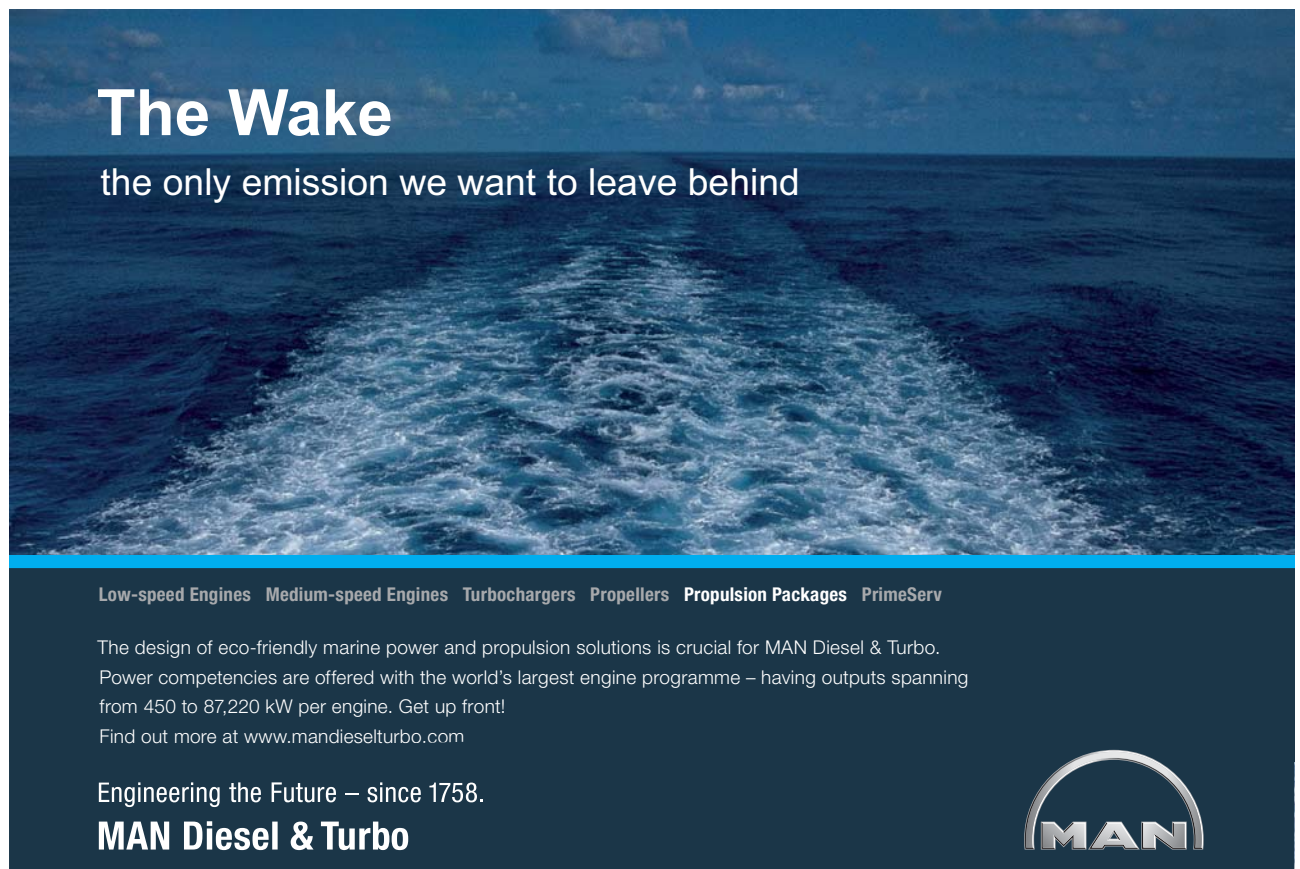

The Wake

the only emission we want to leave behind

Low-speed Engines Medium-speed Engines Turbochargers Propellers Propulsion Packages PrimeServ

The design of eco-friendly marine power and propulsion solutions is crucial for MAN Diesel & Turbo. Power competencies are offered with the world's largest engine programme – having outputs spanning from 450 to 87,220 kW per engine. Get up front! Find out more at www.mandieselturbo.com

Engineering the Future – since 1758.

MAN Diesel & Turbo



Click on the ad to read more

Question 5 Principles of the Resin Transfer Moulding (RTM)

Outline briefly the basic principles of Resin Transfer Moulding (RTM) in the context of design and production of fibre reinforced plastic artefacts.

[5 Marks]

Discuss the requirements of 'blocker' doors in aero-engine thrust reverse systems and why the RTM process has been selected for manufacturing carbon fibre reinforced epoxy versions of them.

[20 Marks]

Question 5a

Resin transfer moulding is based on transfer moulding where the resin is mixed with the hardening agent (catalyst) and inserted into the mould by means of a compression plunger. The reinforcement material, the fiber, is positioned into the mould in advance of this process. The technique is an alternative to manual moulding of the resin and to spraying and compression moulding. The process is usually used for average-size serial production.

The process:

1. Upper section of mould
2. Mould
3. Middle section of mould
4. Resin (basic material)
5. Component part (product) area
6. Product
7. Ejector pin
8. Tapered sprue channel

The resin 4 is filled into a cylindrically shaped chamber of the mould 3. When moved downwards in the Y direction the upper section 1 pushes the plastic mass by means of the plunger into the area 5 of the mould 2 through the opening 8, thus filling the area 5. Once the component has set it is then released from the mould 2 by means of ejector pins 7. The mould is usually pre-heated and additional heat is generated during the "injection" of the resin while it passes through the narrow openings and thin product shapes – thin walls of products.

The RTM technique is suitable for manufacturing products of relatively complex shapes and varying or differing wall thickness. As the resin flows through narrow sections of the product the flow and the heat thus generated help to achieve additional homogenization of the resin, good mixing with reinforcement fibers into the mould and high quality of the composite material and product.

Moulds are a little more expensive than those in compression moulding (CM) and a certain quantity of the resin is usually lost in the sprue. This manufacturing technique is used to manufacture a number of car and aircraft component parts. (Dodge RT/10, 1992 – 40%).

As far as the design of composite material components is concerned, the method ensures good product quality as far as dimensional stability and tolerances are concerned and when complex transitions between different elements are involved. The process features fairly high process efficiency – it is used for manufacturing series of 10^3 and 10^7 component parts.

Question 5 b

1. “Blocker” doors in general

Thrust reversers have various types Blocker doors, C’Ducts and Integrated Cold Stream reversers. The clam shell type utilizes two doors at the rear of the engine, which come together and deflect the exhaust gas to flow in the opposing direction to the motion. This is a fairly simple method of thrust reversal and is common on JT8D engines used on Boeing 737 – 100, ... 200’s. The C’Ducts are the modern type and these have several functions. The prime function is thrust reversal. There are two halves to this type and in thrust reversal there is a translating sleeve which deploys and moves backwards. This causes “Blocker doors” to come up onto the by-pass air and deflect cascade fairing, which direct the air forward to oppose the motion of the aircraft. The second function of this type is noise suppression and acoustics are an important consideration in these units. The other type works similar to the C duct but rather than being a two-half reverser, it is a full annular section. This is commonly used on the RB 211–524 G/H units. Again it uses a translating sleeve and blocker door system to deflect the air from the by-pass through the cascades to oppose the forward motion of the aircraft. The thrust reverser acts along with the brakes of the aircraft to reduce the speed of the aircraft during the touchdown segment of landing. They are particularly useful in situations where the brakes fail or there is a shortened runway.

2. Requirements and operating conditions

Blocker doors in thrust reversers are generally subjected to high load conditions: the pressure of the jet stream, the high temperature of exhaust gas and flaring of the jet engine, vibrations and shocks occurring at engine start up. Moreover, components should have the lowest possible weight and feature high strength characteristics; they shall also be reliable and capable of withstanding fatigue. The function of blocker doors is as illustrated in figure 1.

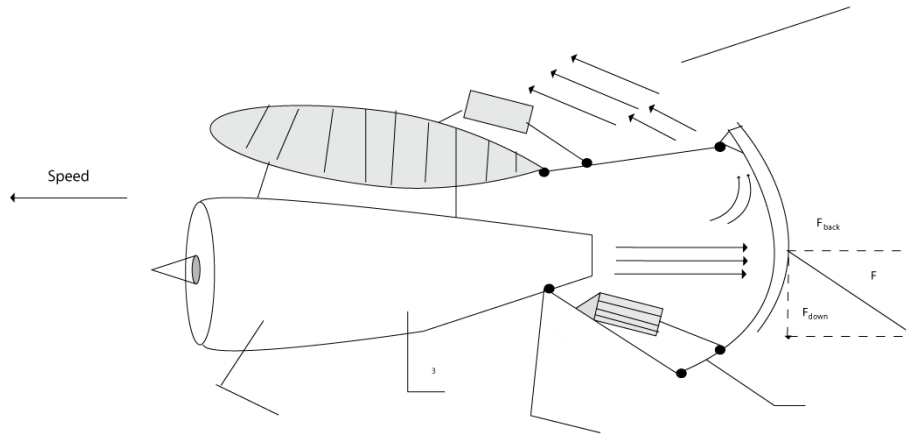

Figure 1

1. Blocker door
2. Shifting system for folding wing
3. (Jet) engine
4. Direction of movement of aircraft
5. Reversed jet stream
6. Wing
7. Engine
8. F – resultant force from the pressure exerted by the reversed jet stream

SMS from your computer

...Sync'd with your Android phone & number

FREE
30 days trial!

Go to

BrowserTexting.com

and start texting from
your computer!

 BrowserTexting

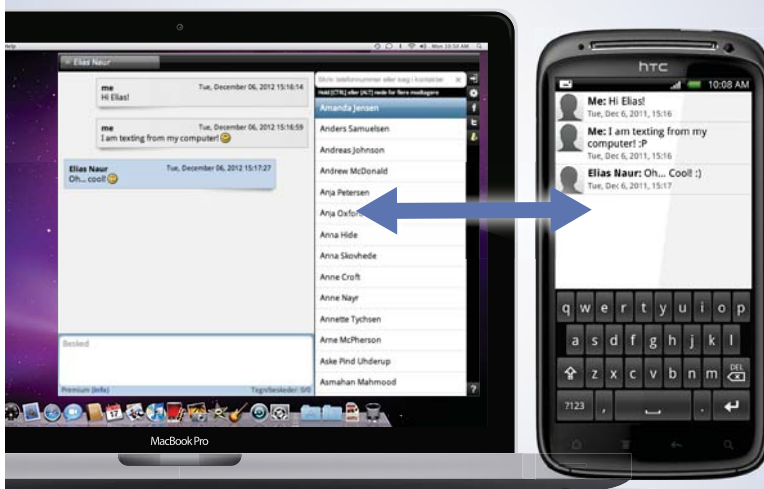

2.1 Blocker doors material

The selected material, carbon fiber reinforced epoxy resin, is suitable for this type of application. Composite blades for helicopter metal blades are now being replaced with blades made of composite materials – S glass fibers in an epoxy matrix. They have high stiffness, strength, resilience and temperature and fatigue resistance, high impact strength also. S-glass features higher fatigue life than E-glass. They are superior to “aramid” or carbon-reinforced composites. But **glass** or **carbon** fiber reinforced hybrid plastics are now being developed for high temperature applications with **continuous use** ranging up to about 300°C. These are used in DC-10 and also Boeings 727 & 777 (9% by total weight- vertical and horizontal tail). Reinforced plastics have reduced fuel consumption by about 2%. Substitution of Al in large commercial aircrafts with graphite-epoxy reinforced plastics could reduce both weight and production cost by 30% with improved fatigue and corrosion resistance. If we examine the diagrams of Tensile strength/% Reinforcement; Impact energy/% Reinforcement; Flexural modulus/% Reinforcement; Flexural strength/% Reinforcement for a carbon fiber-based and glass fiber-based (short and long) composite material, we can see that most carbon fiber (CFRP) characteristics are superior to those of glass-fiber composites with the exception of impact energy. Figure 2 (a, b, c, d).

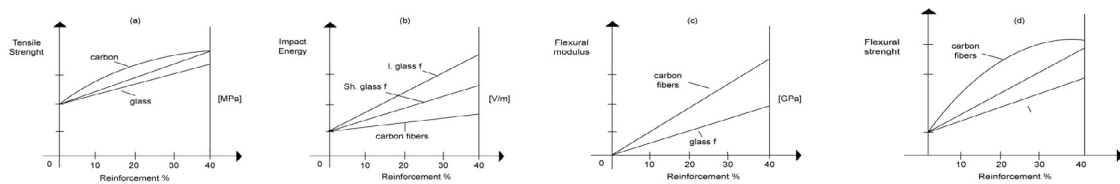

3. Design considerations and selection of the suitable method

We know that the RTM (Resin transfer moulding) method features the following characteristics: it is used to manufacture more complex parts than compression moulding and for higher production rates; some scrap is lost; medium tooling cost. In our particular case this method ensures best characteristics of manufactured components to meet the high operational requirements. Components shall be light in weight, they have coupling elements to connect to particular assembly units involved in the overall mechanism (the reverse thrust system) and ribs are required to be provided along with sudden transitions between thin and thick walls and supports. The RTM method ensures uniform strength for different loading directions which is due to the uniform mixing of reinforcement fibers in the overall mass of the matrix – in our case the epoxy resin. Additionally, the method ensures complete filling of the mould without porosity. Despite of the higher cost of the moulds, the RTM method is very suitable for this particular application.

Question 6 Fibre reinforced plastic composites

In the case of a fibre reinforced plastic composite, explain the varied roles played by the different component parts in producing its physical properties.

[15 Marks]

With the aid of diagrams, describe the 'pultrusion' AND 'vacuum-bag moulding' processes for fabricating composite materials.

[10 Marks]

Question 6a

Composites are a combination of two or more chemically different and non-dissolving constituent compounds, the properties and structure of the resulting composite being superior to those of each individual constituent separately.

Strength stiffness and creep resistance characteristics of plastic materials are usually inferior to those of metals and alloys. Adding reinforcing materials (phases) to the basic matrix of plastic results in significant changes and improvements of characteristics. Thus, the resulting composite material features improved abovementioned characteristics and strength-to-weight and stiffness-to-weight ratios as well as other improved physical properties.

Example: An epoxy resin has the following characteristics: UTC [MPa] = 35-140, E [GPa] = 3.5 – 17, Elongation % 10 – 1. An epoxy-based composite will have UTC [MPa] = 70-1400, E [GPa] = 21 – 52, Elongation % 4 – 2.

6.1. Roles played by different constituents in producing the physical properties of composites

1.1 Reinforcing materials – fibers

These mostly include glass, graphite (carbon), boron. All of them feature very high strength characteristics. Each of them is brittle, tough and poorly elongated itself – they have low structural value as a design material. Actually, the composite is a basic plastic material of homogenous nature, a matrix in which other phases (another phase) of fibers are spread, thus occupying part of the overall volume. The fiber content is usually between 10% and 60%. Material characteristics vary with the percentage of fiber content, the type of reinforcement material and the material of the matrix. For example: glass fibers render high strength, ductility and higher density (compared to carbon). Carbon fibers render higher strength, higher E, lower density (compared to glass fibers and boron). Carbon composites can withstand higher temperatures (1500–3000°). Aramids feature very high specific strength – “Kevlar”. Also, they provide for certain plastic deformation. Boron contains thin tungsten fibers of 0.012mm OD and renders very high tensile strength and high-temperature stability. This is due to the alignment of molecules along fiber length and the small cross-sectional area of the fibers. The smaller the cross-sectional area, the smaller the bending stress of the fibers.

**YOUR WORK AT TOMTOM WILL
BE TOUCHED BY MILLIONS.
AROUND THE WORLD. EVERYDAY.**

Join us now on www.TomTom.jobs

follow us on **LinkedIn**

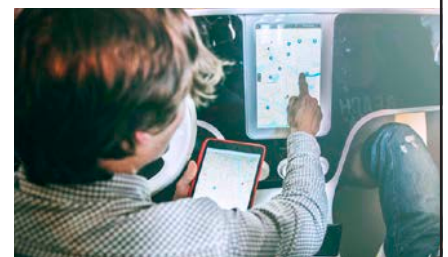

#ACHIEVEMORE

TOMTOM 



1.2 Shape, size and alignment (positioning) of reinforcement fibers

Fibers can either be short (20 ÷ 60) or long (200 ÷ 500). They differ in the fact that if we increase the length of a given fiber and improve its mechanical properties, it is a “short-length” fiber and vice versa. Fibers are usually in the form of continuous rovings, woven fabric, yarn and mats of various combinations. The reinforcing element may also be in the form of particles and flakes. They may be aligned either longitudinally, transversely or scattered throughout the matrix.

1.3 Role played by the matrix

The matrix has the function of absorbing and transferring the stress to the fibers, protecting the fibers from physical damage caused by load conditions and reduce the spreading of cracks inside the composite by virtue of the intrinsic ductility and toughness of the matrix. Materials include resins: epoxy, polyester, phenolic, etc. Polyamide resins withstanding up to 300°C are usually used with graphite fibers.

1.4 Composite characteristics

To conclude we can say that characteristics depend on: the quality of constituents, shape and alignment of fibers, length of fibers and percentage content of the matrix with the reinforcement material. Short fibers are less effective than long ones and their characteristics are far more dependent on time and temperatures. Long fibers provide better load transfer through the matrix and are therefore used for critical condition applications – critical loads and temperatures. These relations are illustrated in the tensile strength/% reinforcement charts (for different fibers), impact energy/reinforcement % charts; flexural modulus/reinforcement % charts, etc., as shown in Figure 2.

Fiber reinforcement affects many other properties of composites, such as heat conductivity, thermal elongation, electrical resistance, stretching resistance, wear, endurance limit – see Figure 3.

A critical factor in reinforced plastics is the strength of the bond between the fiber and the polymer matrix, since the load is transmitted through the fiber-matrix interface. Weak bonding causes fiber pullout and delamination of the structure. Adhesion at the interface can be improved by special surface treatments, such as coatings and coupling agents.

Generally, the greatest stiffness and strength in reinforced plastics is obtained when fibers are aligned in the direction of the tension force – Figure 4.

Figure 4 illustrates the effect of percentage filling of the matrix with fibers and the alignment of fibers relative to tensile strength.

1.5 Strength and elasticity modulus of reinforced plastics

The overall load on the composite is given by the expression:

$$P_c = P_f + P_m$$

and the elastic modulus of the composite is:

$$E_c = x E_f + (1-x) E_m,$$

where x is the cross-sectional area of fibers included in the composite, and

E_f is the elastic modulus of the fiber and E_m is the elastic modulus of the matrix.

The total load on the fiber and the matrix is calculated using the equation:

$$\frac{P_f}{P_m} = \frac{A_f E_f}{A_m E_m}, \text{ where } A_f \text{ is the cross-sectional area of the composite of the fiber}$$

and A_m is the cross-sectional area of the composite for the matrix.

Question 6 b – With the aid of diagrams, describe the “pultrusion” and “vacuum-bag” moulding processes for fabricating composite materials.

6 b 1. Pultrusion is a process used in the manufacturing of various shaped bars such as bars of round or different cross-section of constant shape and dimensions along the entire bar length. This process is similar to drawing long steel bars. Some examples of products made of such bars include golf sticks, fishing rods, machine spindles, guide rails, guides, walkways, etc. The process flow is as follows:.

Base materials for the fiber reinforced material are fed (unwound) from the reels 1 and 2 (continuous rovings and continuous strand mat). The fiber strand is transferred to an impregnating bath 3 containing impregnating resin (epoxy, polyester, other); the mechanism 4 unwinds and laminates the strand with the liner material and the strand is then fed to the unit 5 to undergo preforming. The so formed continuous fiber (strand) is transferred from 5 (by the right movement (+ x)) to the heated forming mould 6. 6 shapes the cross-section of the desired product and hardens. The movement into the + x direction is performed by the puller conveyor 7 (worm-belt type) which transfers the now set in the pre-heated die 6 product to the cut-off saw 8 which cuts desired lengths of finished bars 9.

6 b 2. Vacuum bag moulding

The vacuum bag moulding process is as follows: The basic semi-finished raw material, the resin-impregnated fiber composite base in the form of prepregs 2 is laid into the component mould 1. We know that prepregs is the unhardened raw material composed of reinforcing fibers and resin, which is still an unset plastic mass. This is covered by the flexible bar (bag) 3 and a release cloth or bleeder cloth 8 is inserted in between to prevent sticking to 2, the cloths being made of paper, textiles or plastic sheets. For 2 to adhere to the mould 1, the air has to be pumped out of the space in between through the nozzles 4, thus resulting in a vacuum being created between 1 and 3, with the atmospheric pressure forcing 3 and all layers underneath to stick to the walls of 1. The flexible bar 3 is fixed in its upper end to provide airtight connection with the mould 1 by means of the clamping bar 5 and the gasket 6. A layer of gel coat 7 is provided between 1 and 2 to facilitate ejection of the finished product from the mould 1.

When the resin and reinforcement fibers are laid manually into the mould, the alignment of fibers should be observed. Alignment is also required for prepregs when more than one layers 2 are involved. The resin and fibers may also be sprayed into the mould. Operations described above are performed at room temperature and are one preparatory step for inserting the mould into a pre-heater chamber to speed-up the setting process. Before the mould and materials set is inserted into the pre-heated chamber the mould is closed airtight by means of the cover 9, Figure 2b, which is pressed tightly to 1 along the $Y \downarrow$ direction and pressure of up to 345 [kPa] applied for the cover 1 to be closed airtight and pressed tightly to the layers of resin and fiber reinforcement against the mould. The mould is then heated up in the pre-heated chamber by means of steam or hot water supplied along the pipes 10 to help setting up of materials contained inside. The product is thus finished and released from 1.

Key:

1. Mould
2. Resin and glass
3. Flexible bar (cover)
4. Vacuum trap
5. Clamping bar
6. Gasket
7. Gel coat (mould release)
8. Release cloth, bleeder cloth
9. Cover
10. Steam pipes

Question 7 A cutting test on a steel bar

a)

i. A cutting test on a steel bar was performed and the following values were noted;

F_c – shear force = 680 N

F_t – thrust force = 380 N

R – resultant force (N)

F_s – shear force on shear plane (N)

F – friction force along rake face (N)

N – normal force to rake face (N)

ϕ – shear angle = 20°

α – rake angle = 10°

τ – mean friction angle (degree)

Draw a force diagram, to scale, to show the graphical relationship between these parameters.



Brain power

By 2020, wind could provide one-tenth of our planet's electricity needs. Already today, SKF's innovative know-how is crucial to running a large proportion of the world's wind turbines.

Up to 25 % of the generating costs relate to maintenance. These can be reduced dramatically thanks to our systems for on-line condition monitoring and automatic lubrication. We help make it more economical to create cleaner, cheaper energy out of thin air.

By sharing our experience, expertise, and creativity, industries can boost performance beyond expectations. Therefore we need the best employees who can meet this challenge!

The Power of Knowledge Engineering

Plug into The Power of Knowledge Engineering.
Visit us at www.skf.com/knowledge

SKF

ii. For this test the following values were noted;

w – width of cut = 3.5 mm

t1 – undeformed chip thickness = 0.21 mm

t2 – deformed chip thickness = 0.60 mm

Determine R, τ , E, F_s , cutting ratio, the apparent coefficient of friction μ between tool and the chip, and the apparent shear stress τ_s of the cut material.

iii. For this test the cutting speed was 1 m/s, and the mass flow rate = 3.5 g/s.

Specific heat capacity of the work material was $C = 500 \text{ J/kg}^\circ\text{C}$.

Determine the temperature θ_s at the shear plane assuming 90% of heat is transported with the chip and the original work material temperature was

$\theta_o = 20^\circ\text{C}$. The velocity along the shear plane is given by;

$$V_s = \frac{V_c}{\cos(\phi - \alpha)}$$

b)

Explain what actions may be taken to reduce the rise in coolant temperature in a turning operation.

a) i.

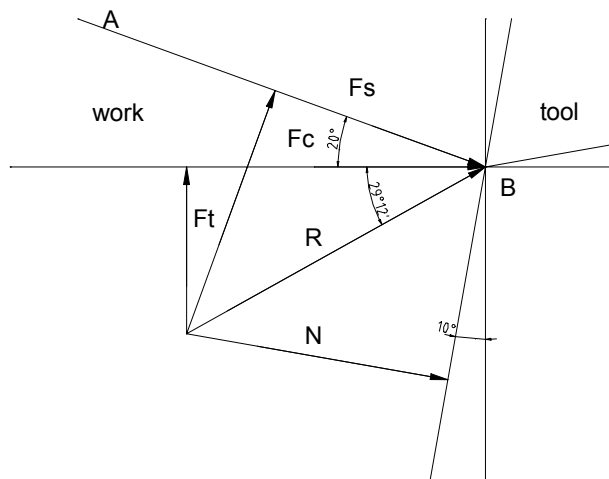

ii.

$$R = \sqrt{(F_c^2 + F_t^2)} = 778,973 \approx 780\text{N}$$

$$\tau = \arctan\left(\frac{F_t}{F_c}\right) + \alpha = 29.2^\circ + 10^\circ = 39.2^\circ$$

$$R = F_s / \cos(\phi + \tau - \alpha) = F_s / \cos 49.2^\circ$$

$$F_s = R \cdot \cos 49.2^\circ = 780 \cdot \cos 49.2^\circ = 509.67\text{N}$$

$$F = R \cdot \sin \tau = 780 \cdot \sin 39.2^\circ = 493\text{N}$$

$$F_c = R \cos(\tau - \alpha) = 780\text{N}$$

$$F_s = swt_t / \sin \phi$$

$$s = \frac{F_s}{2.15} = 237\text{N/m}^2$$

$$\tan \tau = \tan \frac{F}{N} = \mu$$

$$\mu = \tan \tau = \tan 39.2^\circ = 0.8155$$

μ – friction coefficient

Determining the temperature at the cutting plane:

$$m \cdot C \cdot \theta_s = (1 - D) \cdot V_s$$

$$m = 3.5 \text{g} \cdot \text{s}^{-1}$$

$$C = 500 \text{J} / \text{kgC}^\circ$$

$$\theta_s = 20\text{C}^\circ$$

$$\theta = \theta_s + \theta_o$$

$$V_s = V_c \frac{\cos \alpha}{\cos(\phi - \alpha)}$$

$$V_s = 1 \cdot \frac{\cos 10^\circ}{\cos} = 1 \text{ms}^{-1}$$

$$\theta_s = \frac{0.9 \cdot F_s}{m \cdot c} V_s = \frac{0.9 \cdot 680 \cdot 1}{0.0035 \cdot 500} = 349,7\text{C}^\circ$$

$$\theta = 349,7^\circ + 20 = 369,7\text{C}^\circ$$

- b) **The coolant liquid is transferred into the pores of the processed material reducing its surface toughness and reducing cohesion between particles thus facilitating fracture. Friction forces decrease as a result of this action of the coolant.**

<i>Coolant</i>	<i>Shear Force, %</i>
Operation without liquid	100
Mineral water	97
Emulsion	90
Mineral oil	85
Vegetable oil	75

Improvement through steam generation

<i>Method</i>	<i>Cutting speed, %</i>
No cooling operation	100
Usual cooling	125
Steam generation cooling	143

> Apply now

REDEFINE YOUR FUTURE
AXA GLOBAL GRADUATE PROGRAM 2015

redefining / standards 

agence.cdg. © Photonostop



Question 8 Electro-discharge machining (EDM) requirements & properties

a)

- i. Explain why for Electro-discharge machining (EDM) a servomechanism and is essential to the control of the feed.
- ii. Explain the requirements and properties of the EDM dielectric fluid

b)

- i. An electrochemical machining (ECM) process, using a $9\text{ mm} \times 9\text{ mm}$ square tool, is applied to a zinc workpiece. A feedrate of 0.5 mm/s is required. Determine an expression for the volumetric removal rate w (mm^3/s) and hence the current setting I (A) needed. The density of zinc is $\rho = 7.13 \times 10^{-3}\text{ g mm}^{-3}$ and the process has a current efficiency of 90%. Would a machine rated at 1.4 kA be sufficient for the job?

Assume that $m = e.I.t$ where;

m = mass of material removed (g)

e = electrochemical equivalent of zinc = $0.34 \times 10^{-3}\text{ g/As}$

I = current (A)

t = time during which current is applied (s)

- ii. List the advantages and disadvantages claimed for ECM

a)

- i. The method of electric sparking, includes a group of methods based on the process of removing portions of material under high energetic localized heat action as a result of flowing electric impulse discharge between the electrodes in the dielectric fluid.

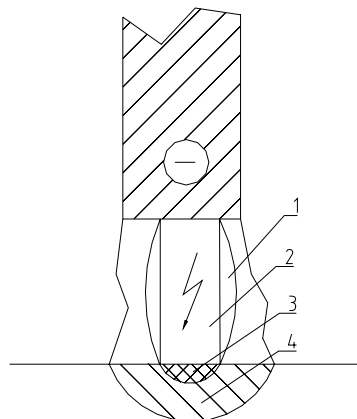

The electrodes are brought closer together at a voltage U that is higher than the breakdown voltage, U_b . This is defined by the dielectric characteristic of the clearance between electrodes δ – in the area of the closest surface plane. The intensity of the field $E=U/\delta$ is reaching a high value (2–3) $6V/m$ and a conductance through (2) is formed representing a relatively narrow cylindrical area of plasma. Flowing through this is the current I with a value of up to 100 A and a very high speed of increase of its value $dI/d\tau \approx (5-8)$ mA/s. The servomechanism ensures equilibrium by controlling feed so the dielectric characteristic of the clearance between electrodes provides $U>U_b$ following each material removal.

- ii. In addition to providing suitable conditions necessary for discharges to take place (breakdown voltage), the dielectric fluid cools the electrodes and flushes away unwanted products of the process. Two types of dielectric fluids are used:

White spirit – operates for a short time at low viscosity and is mainly used for small holes.

Paraffin – has medium operation duration in press stamps, press moulds, etc.

Oil – works for long operations using powerful EDM.

The fluid must be of low unit cost and possess the following properties:

1. Low viscosity to ensure efficient flushing.
2. High flash point.
3. Non-toxic.
4. Non-corrosive.
5. High latent heat (high boiling point)
6. A suitable dielectric strength (resistivity).

The gas- and hydrodynamic processes taking place in the discharge area cause boiling and flowing out of melted material, de-ionization of the area between electrodes and restoration of its dielectric characteristics.

Contaminated dielectric fluid deteriorates sparking processing. Therefore filters are provided to ensure clean fluid.

b)

i.

Volumetric ratio

$W = e.I/ \rho$ (mm^3/s), Where e is electrochemical equivalent $e = 0.34 \times 10^{-3}$ g/As

$\rho = 7.13 \times 10^{-3}$ g mm^{-3}

$$m = e \cdot I \cdot t$$

, Where e is $t = 1 \text{ s}$

$$40 = 0.34 \cdot 10^{-3} \cdot I / 7.13 \cdot 10^{-3}$$

$$\text{Hence } I = 849,3 \text{ A}$$

At 90% efficiency:

$I_{\text{ef}} = I / 0.9 = 943,6 \text{ A}$, hence the power of the machine is adequate for the required 1.4 kA.

ii. Advantages and disadvantages of ECM

In its capabilities ECM is the most universal method for electric processing of metals in all. Almost all kinds of operations involving cutting can be performed using ECM but there are some which have no conventional analogues, like sharpening, grinding (flat, circle, profile), three-dimensional copying, profile processing, broaching, graduating, cutting off, honing, etc.

The disadvantages occur in the reverse relation between quality and efficiency and the necessity to control a great number of factors which complicates overall process control. We also, have relatively low output efficiency and possible risk of ecological contamination. A list with some of the advantages and disadvantages claimed for ECM is presented below:

Advantages

1. No tool wear.
2. High amperage (energy) can be concentrated on small areas.
3. Very high removal rates.
4. Surface finish isn't adversely affected by high removal rates.
5. Cold machining less than 100°C leaving metal properties unaltered.
6. May be applied to tool grinding (Electro-chemical Grinding ECG)
7. No servomechanism required for feed control.

Disadvantages

1. **High initial and running cost of machine and associated equipment.**
2. Extreme pressures and flow rate necessitating special pumping equipment.
3. Extensive tooling and fixtures due to very high electrolyte pressures.
4. Hostile work environment.
5. Tolerances at best 0.05mm (less than EDM)
6. Sludge disposal and hence extraction (hydrogen). Expensive and problematic.

Question 9 Hard and soft automation

- a) **i. Distinguish between “hard” and “soft” automation.**
 - ii. List some of the advantages claimed for mechanical automation in manufacturing.**
- b) **Automatic control systems in CNC are often called servomechanisms. Explain what they are and what their purpose is. Your answer should include mention of open and closed loop systems, transducers and servomotors.**
- c) **The end of an industrial robot wrist is usually termed an “end effector”. List tools and devices, which end effectors, are commonly equipped with?**
- a) **i. Automation can generally be defined as the process of following a predetermined sequence of operations with little or no human labor, using specialised equipment and devices that perform and control manufacturing processes.**

In hard, or fixed-position, automation, the production machines are designed to produce a standardized product, such as engine blocks, valves, gears, or spindles. Although product size and processing parameters (such as speed, feed, and depth of cut) can be changed, these machines are specialised. They lack flexibility and cannot be modified to any significant extent to accommodate products that have different shapes and dimensions. Machines used in hard-automation applications are usually built on the building block, or modular principle. They are generally called transfer machines, and consist of the following two major components: powerhead production units and transfer mechanisms. Because these machines are expensive to design and construct, their economic use requires mass production of parts in very large quantities.

It has been stated that hard automation generally involves mass-production machines that lack flexibility. In soft (or flexible) automation, greater flexibility is achieved through computer control of the machine and its various functions using a lot of programs. Soft automation is an important development because the machine can be easily and readily reprogrammed to produce a part that has a different shape or dimensions than the one just produced. Because of this capability, soft automation can produce parts with complex shapes. Advances in flexible automation, with extensive use of modern computers, have led to the development of flexible manufacturing systems with high levels of efficiency and productivity.

- ii. Some of the advantages, which are claimed for mechanical automation, are presented below:
- Responsiveness to shorter product life cycles, changing market demand, and global competition.
 - Emphasis on product quality and its uniformity through better process control.
 - Better use of materials, machinery, and personnel, and reduction of work-in-progress inventory, thus improving productivity and lowering product cost.
 - Better control of production, scheduling, and management of the total manufacturing operation, resulting in lower product cost.
 - Standardization of process plans, thus improving the productivity of process, reducing lead times, reducing planning costs, and improving the consistency of product quality and reliability.
 - Parts can be produced randomly and in batch sizes as small as one and at lower unit cost.
 - Direct labor and inventories are reduced, with major savings over conventional systems.
 - Production is more reliable because the system is self-correcting and product quality is uniform.
 - High-quality parts at low cost.
 - Reduced inspection and rework of parts



LIGS University
based in Hawaii, USA

is currently enrolling in the
Interactive Online **BBA, MBA, MSc,**
DBA and PhD programs:

- ▶ enroll **by October 31st, 2014** and
- ▶ **save up to 11%** on the tuition!
- ▶ pay in 10 installments / 2 years
- ▶ Interactive **Online** education
- ▶ visit www.ligsuniversity.com to
find out more!

Note: LIGS University is not accredited by any nationally recognized accrediting agency listed by the US Secretary of Education. More info [here](#).



- a) Automatic control systems are sometimes called servomechanisms. They may be a complex array of electromechanical components or it may be just a simple mechanical device. These are power units, which control the line of movement of the tool and/or the work.

An *open loop system* is the simplest form of servomechanism. It is characterised as a system, which lacks feedback i.e. there is no sensing device to confirm the action of the control signal.

A closed loop system is characterised by the presence of feedback. It makes use of an error detector that returns a signal proportional to the difference between input and feedback i.e. error activated and strives to make the error zero.

Typical CNC servomechanisms include the following components:

- i. *Transducers* which is defined as any device that senses an output condition and transforms the sensed information into a form that which can be understood by the servo system. A device that outputs a voltage in direct proportion to a measured linear movement is a typical example.
- ii. Servomotors, or drives, are devices that convert electrical command signals to mechanical motions. Digital to analogue converters may be required to convert digital commands from the machine control unit to a continuous voltage, which in turn is used as the control signal to the axial drive.
- c) In the terminology of robotics, an end effector can be defined as a device which is attached to the robot's wrist to perform a specific task. The task might be work such as handling, spot welding, spray painting, or any of a great variety of other functions. The end effector is the special-purpose tooling which enables the robot to perform a particular job. Robot's wrists are commonly equipped with devices such as grippers, and tools.

Grippers are used to hold either workparts or tools. The most common grasp methods used in robot grippers are:

- **Mechanical grippers**, where friction or the physical configuration of gripper retains the object
- **Suction cups (also called vacuum cups)**, used for flat objects
- **Magnetized gripper devices**, used for ferrous objects
- **Hooks**, used to lift parts off conveyors
- **Scoops or ladles** used for fluids, powders, pellets, or granular substances.

There are a limited number of applications in which a gripper is used to grasp a tool and use it during the work cycle. In most applications where the robot manipulates a tool during the cycle, the tool is fastened directly to the robot wrist and becomes the end effector. A few examples of tools used with robots are the following:

- **Spot welding gun**
- **Arc welding tools (and wire-feed mechanisms)**
- **Spray painting gun**
- **Drilling spindle**
- **Routers, grinders**
- **Heating torches.**

TURN TO THE EXPERTS FOR **SUBSCRIPTION** CONSULTANCY

Subscribe is one of the leading companies in Europe when it comes to innovation and business development within subscription businesses.

We innovate new subscription business models or improve existing ones. We do business reviews of existing subscription businesses and we develop acquisition and retention strategies.

Learn more at [linkedin.com/company/subscribe](https://www.linkedin.com/company/subscribe) or contact
Managing Director Morten Suhr Hansen at mha@subscribe.dk

SUBSCR✓**BE** - to the future



Question 10 Surface integrity of manufactured surfaces: properties & applications

- a) Briefly explain the meaning of 'surface integrity' in relation to manufactured surfaces and their properties and applications.
- b) Engineering parts require varying surface characteristics according to their function. List reasons for these varying requirements.
- c) A magnified pen recording from a stylus type surface texture measuring instrument shows a pattern approximating to a series of triangles $H = 6 \text{ mm}$ the horizontal magnifications were $\times 20$ and $\times 2000$ respectively. Determine a relationship between H and R_a and hence the R_a (μm) value. Is this in the normal range for a turned surface? What factors do you think caused this regular pattern to be produced on the work?
- d) When considering the evaluation of fine manufactured surface using light interference methods, with the aid of a sketch show that the difference in separation between adjacent interference fringes is equal to $\lambda/2$ where λ is the wavelength of monochromatic light of an incident ray L_1 .

- a) In manufacturing processes, surfaces and their properties are as least as important as the bulk properties of the materials. Surface integrity describes not only the topological (geometric) aspects of surfaces, but also their mechanical and metallurgical properties and characteristics. Surface integrity is an important consideration in manufacturing operations because it influences the properties of the product, such as its fatigue strength and resistance to corrosion and its service life.

Therefore, surface integrity pertains to properties such as fatigue life and corrosion resistance, which are influenced strongly by the type of surface produced. Factors influencing surface integrity are temperatures generated during processing, residual stresses, metallurgical (phase) transformations, surface plastic deformation, tearing and cracking.

Several defects caused and produced during manufacturing can be also identified. They may be responsible for lack of surface integrity. These defects are usually caused by a combination of factors, such as defects in the original material, the method by which the surface is produced, and lack of control of process parameters that can result in excessive stresses and temperatures.

- b) Roughness has direct influence on the size of initial operational clearance and also on the duration of the operation (surfaces of lower roughness take less time to finish). The time that moving assemblies last largely depends on initial roughness of assembled surfaces which does not imply that wear will be proportional to surface roughness. At very low roughness surface lubrication deteriorates as a result of which wear is increased. Achieving a very smooth surface is rather expensive. Roughness has direct influence on the toughness of the assembly in press fits. Frequently disassembled press fits require less roughness and vice versa.

Depressions and roughness are areas of concentrated stress and influence fatigue strength. For example, parts subjected to grinding are 40%–50% more resistant to cyclical loads compared to parts subjected to turning. Moreover, roughness is a reason for the occurrence of cracks. Corrosion resistance is directly influenced by roughness – acids, salts, water, etc. are easily retained in rough areas.

$$c) R_a = \frac{1}{L} \int_0^L (Y) dx \approx R_a = \frac{1}{n} \sum_{i=1}^n |Y_i|$$

$$R_a \approx \frac{1}{n} \sum_{i=1}^n (Y_i)$$

where n is the number of measured deviations; Y_i – are X quotient values within the limits of the base length.

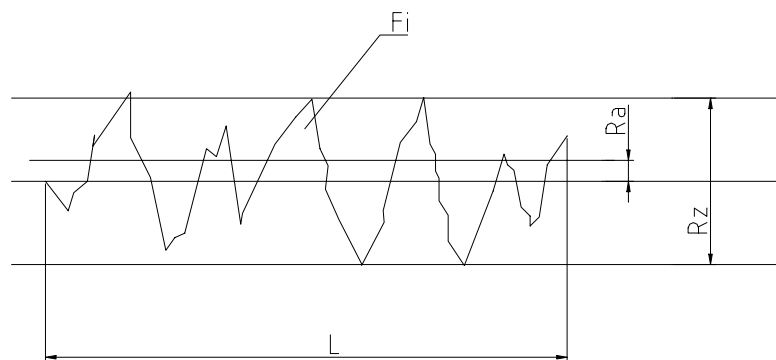

According to the given conditions and when $R_a = S \text{ (mm}^2\text{)/V(mm)}$

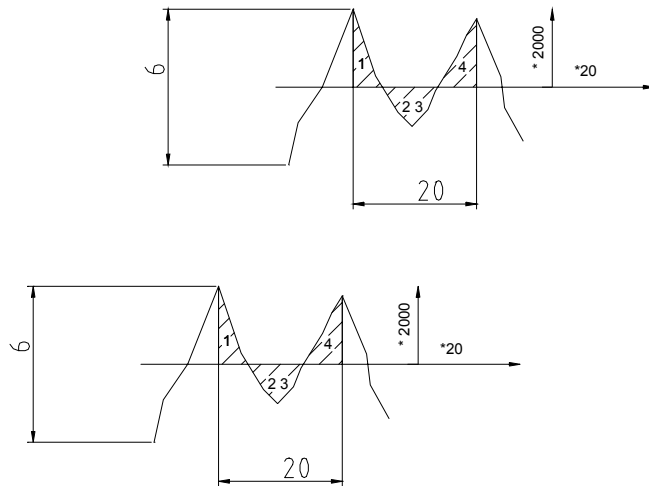

We can now, determine the arithmetic mean value:

$$R_a = \frac{4 \times \frac{3 \times 5}{2}}{20} \times \frac{10^3}{2000} = 0.75 \mu\text{m}$$

The parameter, which causes the occurrence of the irregular profile of the component, is roughness. It is considered as a combination of micro irregularities forming surface profile.

During machining, removal of chip irregularities occurs as traces of the cutting tool. Similar effect is noticed in plastic processing during molding from stamps, moulds and also from some external inclusions like oxides, sand, etc.

Moreover, roughness is dependent on material strength characteristics, vibrations, temperature, coolant type, etc.

Question 11 Bored holes – plug and gap gauges

- a) A plate cam, 25 mm thick, has a bored hole at its centre of rotation in which a keyway, 5 mm wide and 4 mm deep, is to be broached
- Given the empirical expression; broach tooth pitch (mm) = $1.77 \sqrt{\text{bore length}}$, determine, the length of the cutting portion of the broach and the maximum force required to pull it through the hole if the rise per tooth of the broach is 0.09 mm, and the force to remove 1 mm^2 of metal is 2500N.
 - Explain why knowledge of this force is desirable for manufacturing purposes.
- b) The following values are taken BS 4500 and refer to a ‘average location’ for round hole and shaft of 50 mm nominal diameter. What is meant by a ‘nominal’ diameter?

Hole H7 +0.025 mm
+0.000 mm



“I studied English for 16 years but...
...I finally learned to speak it in just six lessons”
Jane, Chinese architect

ENGLISH OUT THERE

Click to hear me talking before and after my unique course download

**Shaft g6 -0.009 mm
-0.025 mm**

Draw a simple diagram representing the hole and on it show, with numerical values;

- i. nominal diameter**
- ii. tolerances**
- iii. deviations**

What kind of fit is achieved?

Sketch suitable plug and gap gauges to check this hole and shaft.

Indicate the GO and NOT go sizes.

a) i.

$$p = 1.77\sqrt{25} = 1.77 * 5 = 8.85\text{mm}$$

$$\text{Number of teeth } Z = 4/0.09 = 44.44 \rightarrow 45 \text{ mm}$$

$$\text{Length } L = p \times Z = 398.25 \rightarrow 400 \text{ mm } 8.85 \times 45$$

$$\text{Number of teeth in contact } - z c = H / p = 25/8.85 = 2.82 \rightarrow 3$$

$$\text{The force } F = \text{area } \times z c \times k = (5 \times 0.09) \times 3 \times 2500 = 3375 \text{ N}$$

ii.

Knowledge for this force is needed when considering the capabilities of the machine where broaching is going to be carried out.

b)

The nominal diameter is the dimension calculated from the static or kinematic strength of the material by considering kinematic and dimensional chains or taking into account other conditions and considerations and rounding them to the closest highest value in the standard.

BS 4500

D = 50 mm

Hole ϕ 50 H7

Shaft ϕ 50 g6

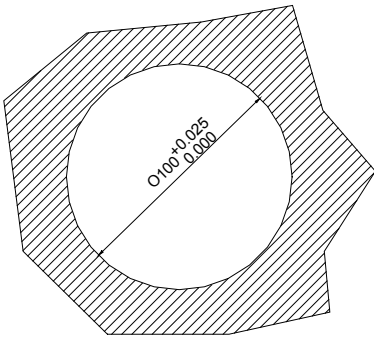
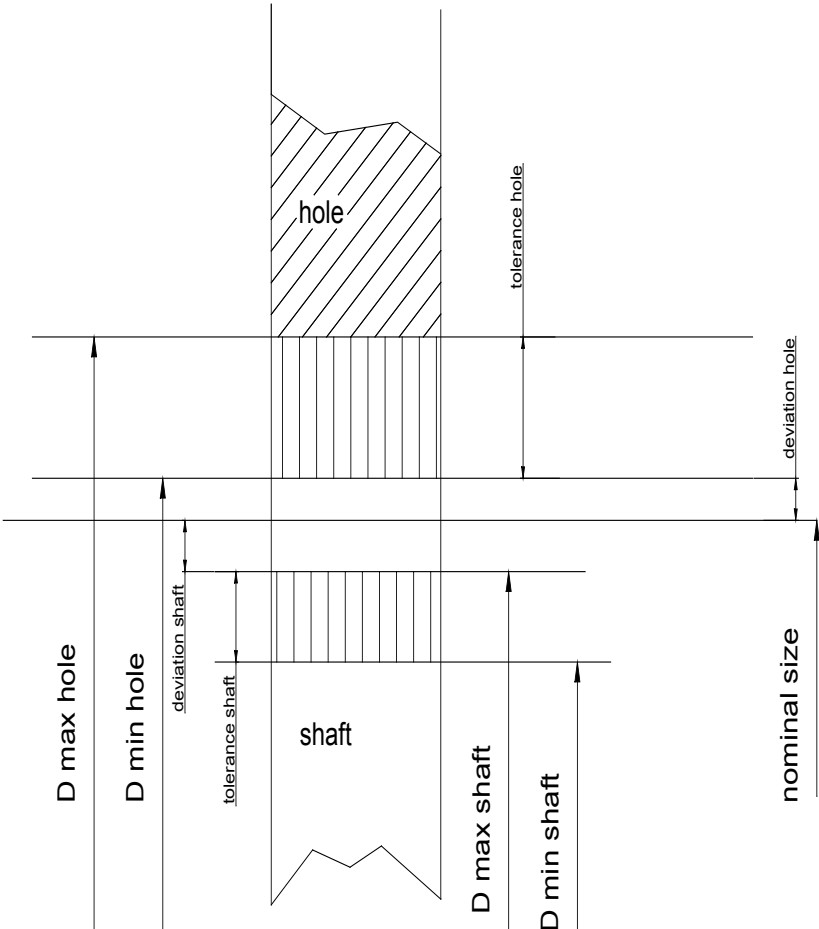

O50 H7

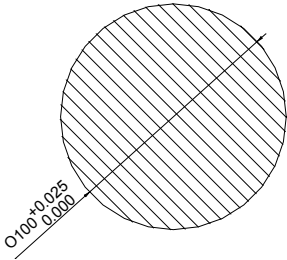

O50 g6

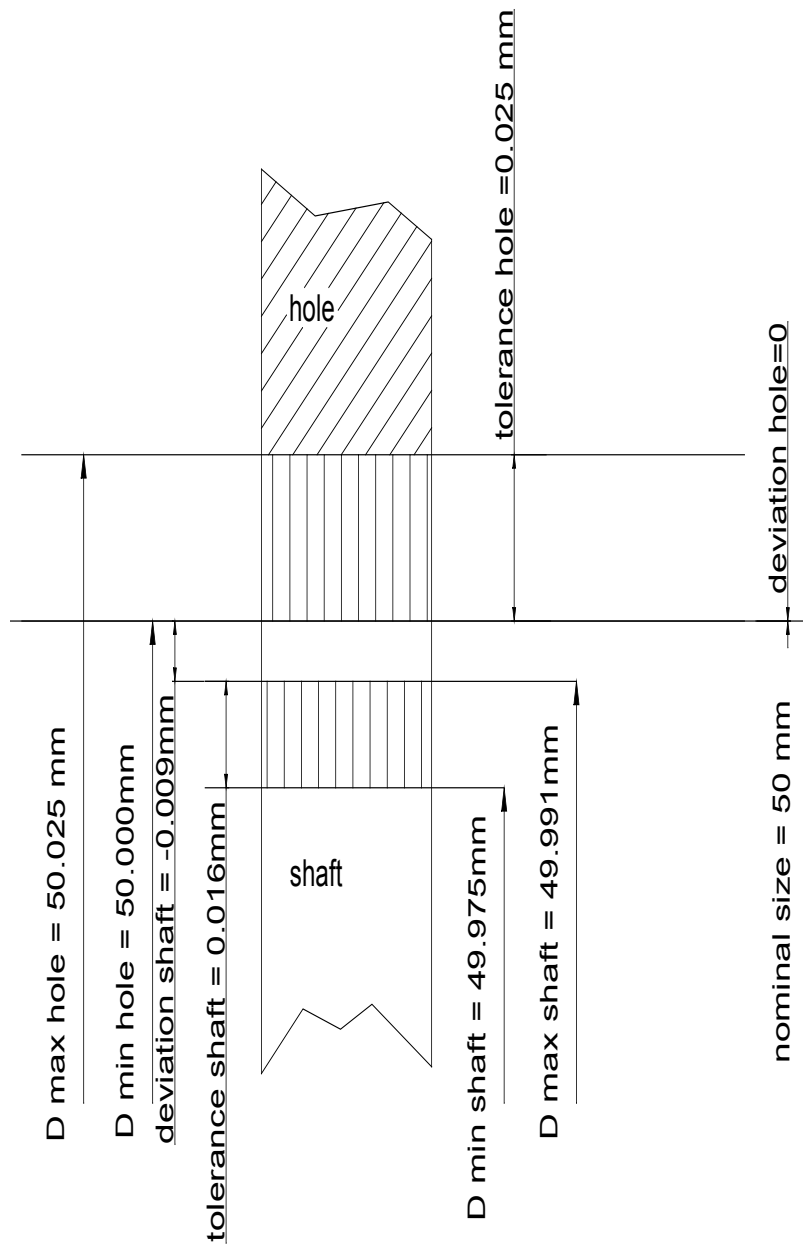

Type of fit

Average location fit

Suitable for precision, sliding and location.

Suitable for a hole $\phi 50$ H7

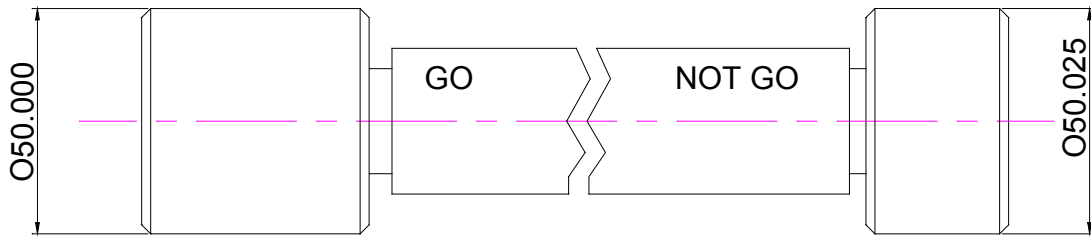

Suitable for a shaft $\phi 50$ g6

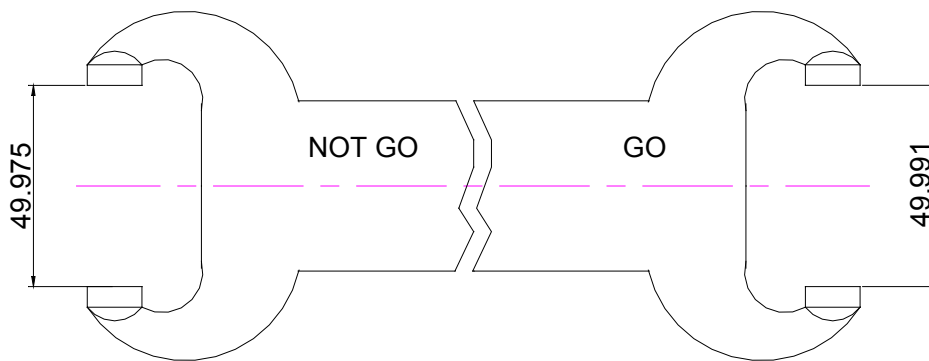

wethrive.net

How to retain your top staff

FIND OUT NOW FOR FREE

DO YOU WANT TO KNOW:

- What your staff really want?
- The top issues troubling them?
- How to make staff assessments work for you & them, painlessly?

Get your free trial

Because happy staff get more done



Question 12 Integrated Manufacturing Systems: a facility of large and small machines

In a manufacturing facility three large and two small process machines need to be taken out of service for tool changing servicing. The frequency of this activity is primarily dependent on the production schedule. The work is carried out by a team of specialist engineers. The sequence of events has been observed and can be broken down into the following operations:

- an electrician disconnects the power supply 10 minutes
- a pair of men pull the machine from its mountings 2 hours
- a fitter removes the fittings 20 minutes
- a tool engineer changes the tooling and resets the machine datums

The machine is reinstalled to its production location in reverse order of the above operations. There is one large space and one small space available for this work and small machines can be serviced in either space but the large machines require a large space.

The run time for the entire machine process varies from 5 to 25 hours. The time to change tooling and reset machine datums varies from 4 to 6 hours.

A closed discrete simulation of this facility is required to check if it is feasible to increase the number process machines in the facility, there is sufficient space to add one large machine within the existing site.

- a) Identify and indicate the entities within the system. **[6 Marks]**

- b) Develop a complete activity cycle diagram of the system. **[14 Marks]**

- c) Explain how dismantling activities could take priority over reassembly activities **[5 Marks]**

a) **Defining entities**

- Large machine 1
- Large machine 2
- Large machine 3
- Large machine 4 (additionally included to check if it is possible to install it in the production premises)
- Small machine 1
- Small machine 2
- Power supply specialist
- Two men for separation from the foundations
- Mechanic
- Tooling engineers
- Large bay
- Small bay

b) **To build the cycle of activities I will need to describe each entity involved in the production premises:**

Entity	Status
Large bay (the cycle is similar to that for the small bay)	In action (A) Idle (Q)
Power supply specialist (the cycle is similar to that for the two men for separation from the foundation and for the mechanic)	- disconnecting (A) - waits (Q) - connecting (A)
Tooling engineer	- works on the large bay (A) - waits (Q) - works on the small bay (A)
Large machine 1 (the cycle is similar for the rest of the machines)	- waits for tool change (Q) - disconnecting cables (A) - waits (Q) - separation from foundation (A) - waits (Q) - coupling disconnection (A) - waits (Q) - tool change (A)

- waits (Q)
- coupling connection (A)
- waits (Q)
- fastening to the foundation (A)
- waits (Q)
- connecting cables (A)
- finished machine (Q)
- operates according to the production schedule (A)

Defining the cycle of individual entities

Large bay (small bay) – Figure 12.1

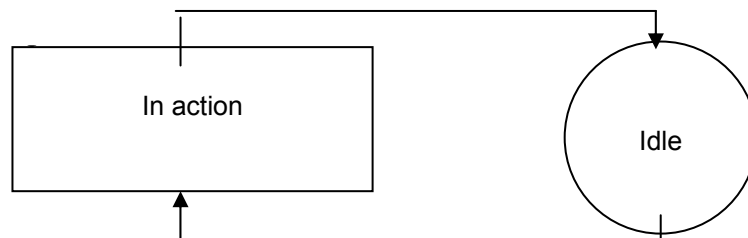

Figure 12.1

gaiteye
Challenge the way we run

EXPERIENCE THE POWER OF FULL ENGAGEMENT...

**RUN FASTER.
RUN LONGER..
RUN EASIER...**

**READ MORE & PRE-ORDER TODAY
WWW.GAITEYE.COM**

Power supply specialist (two men for separation from the foundation; mechanic) – Figure 12.2

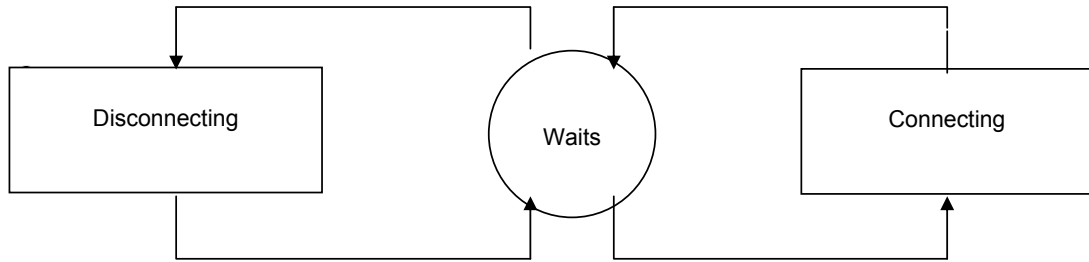

Figure 12.2

Tooling engineer – Figure 12.3

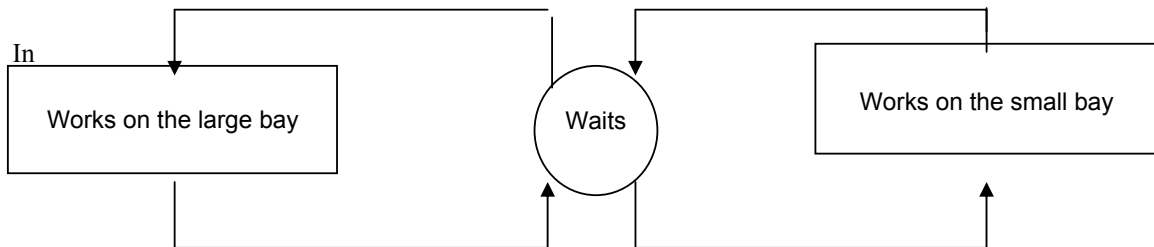

Figure 12.3

The simplified cycle of activities of the machine is as illustrated in Figure 6.4

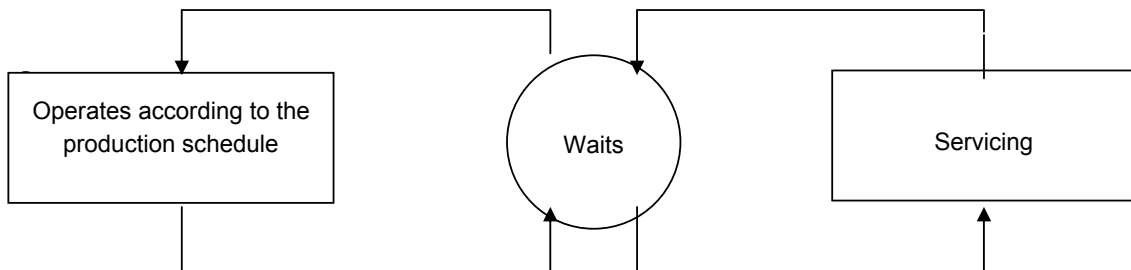

Figure 12.4

are included in a single operational activity – dismantling and mounting in the reverse order. These activities are all carried out by the same staff.

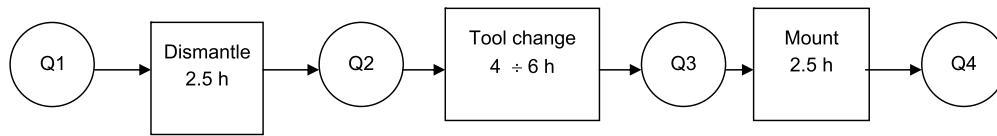

Figure 12.6

From the model built in Figure 12.6 we could draw the conclusion that there should be no activities queuing in Q1. However, it is possible to have activities queuing in Q2 and Q3. Thus all dismantling operations will be completed and activities will be queuing in Q2. Having completed all dismantling activities the team will then proceed with machine assembly and tool change operations.

This e-book
is made with
SetaPDF



SETASIGN

PDF components for PHP developers

www.setasign.com



Question 13 Simulation method, determining the time to complete the batch and the machine utilisation

(a) The process flow chart shown in Figure Q4(a) represents four machines which can process two types of component A and B. Each component requires an operation to be performed by each machine in sequence.

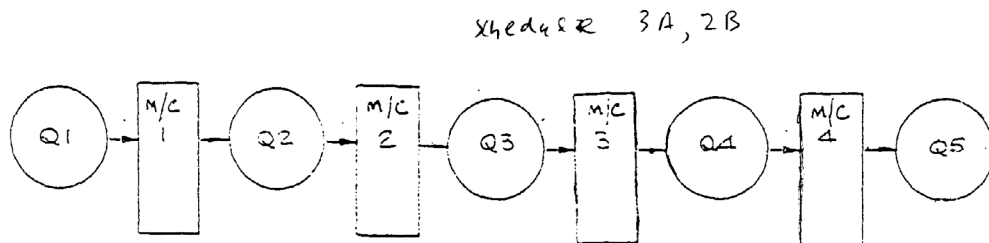

Figure Q13(a)

The following data is available:

Product	Process Time (mins)			
	M/C 1	M/C 2	M/C 3	M/C 4
A	5	4	7	2
B	8	3	5	5

Table Q13(a)

Using a hand simulation method, determine the time to complete the batch and the utilisation of each machine.

[12 Marks]

1. Estimating lot processing time using the manual simulation technique

To build a model of the specified problem we will need to define the entities to be involved in this exercise. These include:

- | | |
|--------------|--------------|
| 1. Part A | 4. Machine 2 |
| 2. Part B | 5. Machine 3 |
| 3. Machine 1 | 6. Machine 4 |

Having defined the entities to be involved, we now have to describe them:

Entity	Status
Part 1	<ul style="list-style-type: none"> - Workpiece (waits for machine 1) (Q)* - Machining on machine 1 (A)** - Waits for machine 2 (Q) - Machining on machine 2 (A) - Waits for machine 3 (Q) - Machining on machine 3 (A) - Waits for machine 4 (Q) - Machining on machine 4 (A) - Finished part (Q)
Part 2	<ul style="list-style-type: none"> - Workpiece (waits for machine 1) (Q) - Machining on machine 1 (A) - Waits for machine 2 (Q) - Machining on machine 2 (A) - Waits for machine 3 (Q) - Machining on machine 3 (A) - Waits machine 4 (Q) - Machining on machine 4 (A) - Finished part (Q)
Machine 1	<ul style="list-style-type: none"> - Machines part (A) - Idle (Q)
Machine 2	<ul style="list-style-type: none"> - Machines part (A) - Idle (Q)
Machine 3	<ul style="list-style-type: none"> - Machines part (A) - Idle (Q)
Machine 4	<ul style="list-style-type: none"> - Machines part (A) - Idle (Q)

We can provide a simpler description for Part 1 and Part 2.

Entity	Status
Part 1	Workpiece (Q)
	Machining (A)
	Finished part (Q)
Part 2	Workpiece (Q)
	Machining (A)
	Finished part (Q)

We can now draw a flow diagram of the life cycles of Part 1, Part 2, Machine 1, Machine 2, Machine 3 and Machine 4, as illustrated in Figure 13.1

Part 1

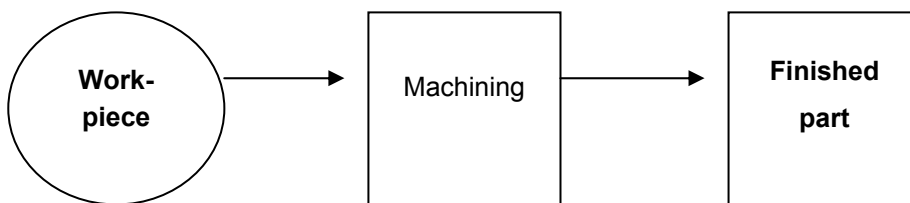

Discover the truth at www.deloitte.ca/careers

Deloitte.

© Deloitte & Touche LLP and affiliated entities.



Click on the ad to read more

Part 2

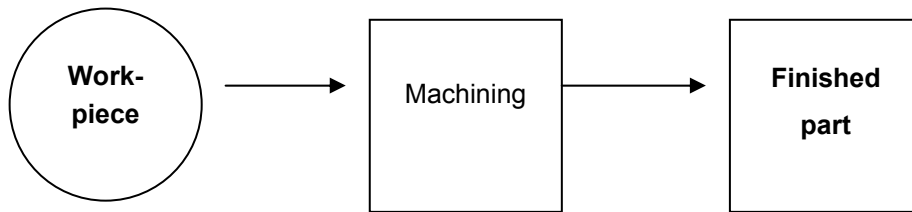

Machines 1; 2; 3; 4

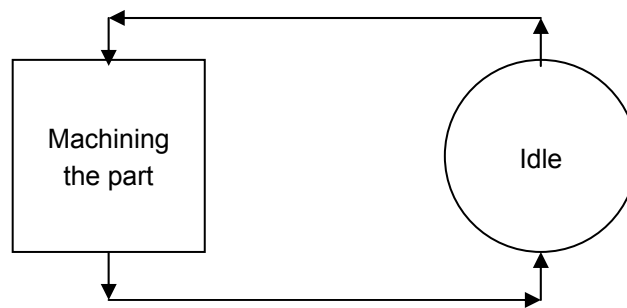

Figure 13.1

Having considered the life cycles of defined entities we now have to define queues and activities.

Data description of the activities and queues.

I use as a model (Figure 7.2) the specified technological sequence of machining individual parts assuming the first parts to be machined are A1, A2 and A3 and then follow B1 and B2.

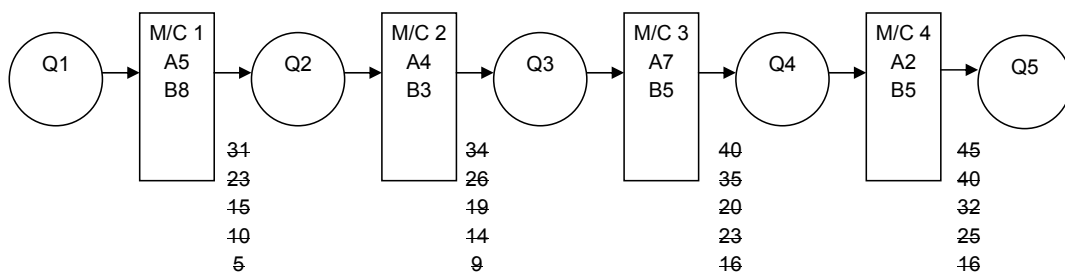

Figure 13.2

To record the simulation I will use the “Simulation record sheet”, Figure 7.3.

The result of the performed simulation is that the specified lot of component parts will take 45 minutes to process.

Machine 1 – operates from 0 to 31 min with no idle time.

Machine 2 – operates from 5 to 54 min with 11 min idle time.

Machine 3 – operates from 9 to 40 min with no idle time.

Machine 4 – operates from 16 to 45 min with 13 min idle time.

Therefore, the most heavily loaded machines are:

Machine 1 – operates for 31 minutes, and

Machine 3 – operates for 31 minutes.

Time	End	Start	Sim. Clock Time	IDLE TIME ON MACHINES												NUMBER OF JOBS IN QUEUES						
				MACHINE 1			MACHINE 2			MACHINE 3			MACHINE 4			Q1	Q2	Q3	Q4	Q5		
				ON	OFF	DUR	ON	OFF	DUR	ON	OFF	DUR	ON	OFF	DUR							
0	0	✓	0		✓	0												4	0	0	0	0
✓	✓	✓	5	✓	✓			✓	5									3	0	0	0	0
✓	✓	✓	9				✓				✓	9						3	0	0	0	0
✓	✓	✓	10	✓	✓	0		✓	1									2	0	0	0	0
✓	✓	✓	14				✓											2	0	1	0	0
✓	✓	✓	15	✓	✓	0		✓	1									1	0	1	0	0
✓	✓	✓	16							✓	✓	0		✓	16			1	0	0	0	0
✓	✓	✓	18										✓					1	0	0	0	1
✓	✓	✓	19				✓											1	0	1	0	1
✓	✓	✓	23	✓	✓	0		✓	4	✓	✓	0		✓	5			0	0	0	0	1
✓	✓	✓	25										✓					0	0	0	0	2
✓	✓	✓	26				✓											0	0	1	0	2
✓	✓	✓	30							✓	✓	0		✓	5			0	0	0	0	2
✓	✓	✓	31	✓				✓	5									0	0	0	0	2
✓	✓	✓	32										✓					0	0	0	0	3
✓	✓	✓	34				✓											0	0	1	0	3
✓	✓	✓	35							✓	✓	0		✓	3			0	0	0	0	3
✓	✓	✓	40							✓			✓	✓	0			0	0	0	0	4
✓	✓	✓	45										✓					0	0	0	0	5

Figure 13.2

(b) Three types of product are processed through machining centres for 1 to 3 operations, followed by wash and inspect. The pans are moved on transfer pallets, which are recycled within the cell. The plant is expected to operate 280 days per annum at 20 hours per day. Anticipated annual demand is for 30,000 units, with 50% type A, 25% type B and the remainder type C.

The following data is available, all times are in minutes.

Part Type	Machining Times			Wash Time	Inspection Time
	OP1	OP2	OP3		
A	15	12	-	5	8
B	9	9	6	5	6
C	16	7	-	5	9

Table Q13(b)

Determine the provisional number of machining centres, wash stations, inspection stations and pallets to be included in a simulation model.

[13 Marks]

Preparing a block diagram along with activity times and rules of operation. To build the simulation model we will need to define the entities to be involved.

1. Part A
2. Part B
3. Part C
4. Machine 1
5. Machine 2
6. Machine 3
7. Washing work station
8. Inspection work station

Description of entities:

- Part A - Workpiece (waits M/1) (Q)
- Machining on M/1 (A)
 - Waits M/2 (Q)
 - Waits for washing work station (Q)
 - Washing work station (A)
 - Waits for inspection work station (Q)
 - Inspection work station (A)
 - Finished part (Q)
- Part B - Workpiece (waits M/1) (Q)
- Machining on M/1 (A)
 - Waits M/2 (Q)
 - Machining on M/2 (A)
 - Waits for M/3 (Q)
 - Machining on M/3 (A)

- Waits for washing work station (Q)
- Washing work station (A)
- Waits for inspection work station (Q)
- Inspection work station (A)
- Finished part (Q)

- Part C
- Workpiece (waits M/1) (Q)
 - Machining on M/1 (A)
 - Waits for M/2 (Q)
 - Machining on M/2 (A)
 - Waits for washing work station (Q)
 - Washing work station (A)
 - Waits for inspection work station (Q)
 - Inspection work station (A)
 - Finished part (Q)

Machine 1 – Machines part (A)

- Idle (Q)

Machine 2 – Machines part (A)

- Idle (Q)

© 2013 Accenture. All rights reserved.

be > your degree

Bring your talent and passion to a global organization at the forefront of business, technology and innovation. Discover how great you can be.

Visit accenture.com/bookboon

Be greater than.
consulting | technology | outsourcing

accenture
High performance. Delivered.



Machine 3 – Machines part (A)

- Idle (Q)

Washing work station – Process part (A)

- Idle (Q)

Inspection work station – Process part (A)

- Idle (Q)

First we build the simulation model of each of the three parts A, B and C.

Simulation model of part A (Figure 13.4)

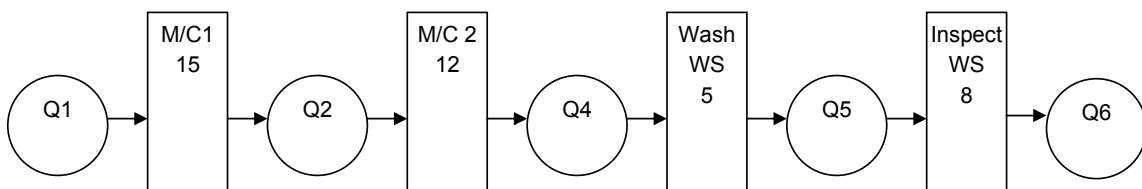

Figure 7.4

Simulation model for Part B (Figure 13.5)

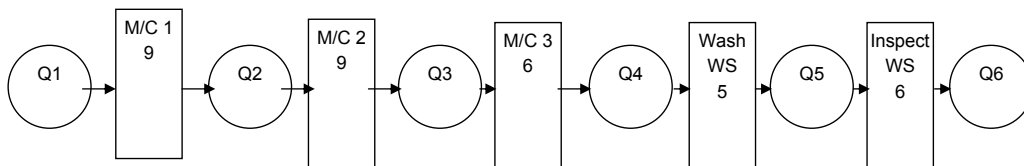

Figure 7.5

Simulation model of part C (Figure 13.6)

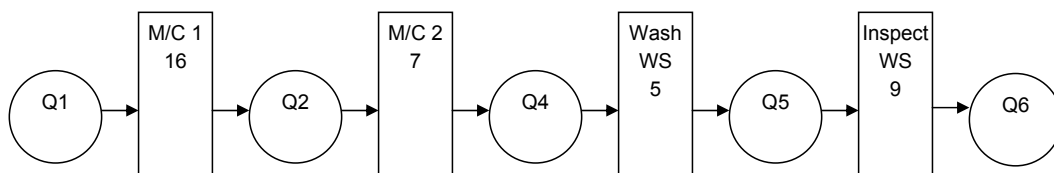

Figure 13.6

Parts A and C feature identical simulation models. The simulation model for Part B differs for the additional machining on M/c 3.

Building a general simulation model – Figure 13.7

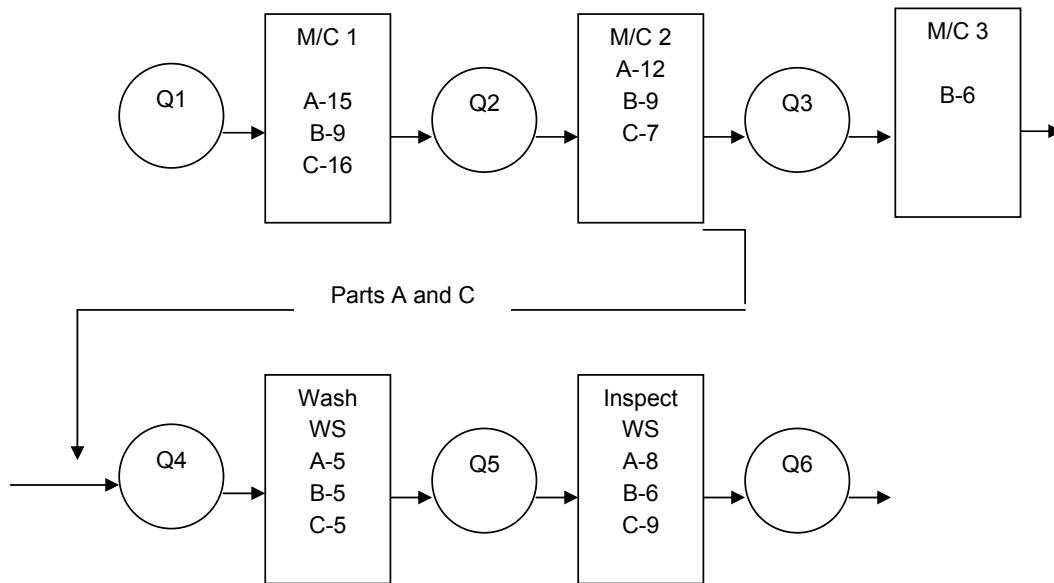

Figure 13.7

Facilities required for the simulation model are:

- Machining centres – 3
- Inspection work stations – 1
- Washing work stations – 1
- Transportation pallets – 11

We can now make a simulation of the model using 8 parts. Four parts of the A type are machined first, 2 parts of the C type and finally, 2 parts of the B type. The draw the simulation as illustrated in Figure 4.8:

Analysis of the Simulation Process

The first part A will be finished for 40 minutes and the second part, for 55 minutes. Therefore, every subsequent part will be finished for 15 minutes (this is the step size).

The time between the last part A and the first part C (finished) is 12 minutes. The step between parts C is 16 minutes. The time between the last part C and the first finished part B is 14 minutes. The step of parts B is 9 minutes.

The annual schedule for parts A is 15000 pieces; parts B – 7500 pieces and parts C – 7500 pieces.

The time required to process the whole lot is as follows:

$$\begin{aligned} T_{\text{lot}} &= 40 + 14999 \times 15 + 12 + 7499 \times 16 + 14 + 7499 \times 9 = \\ &= 40 + 224985 + 12 + 119984 + 14 + 67491 = 412526 \text{ min} \end{aligned}$$

Annual working time:

$$T_{\text{ann}} = 280 \cdot 20 = 5600 \text{ hours} \times 60 = 336000 \text{ min.}$$

Comparing both times we find:

$$T_{\text{lot}} > T_{\text{ann}}$$

Therefore, this particular lot cannot be processed within one year.

Analysing the simulation thus carried out we find the bottle neck issues are:

1. Machine 1 and machine 2 for part A
2. Machine 1 for part C

We can now determine the time required to implement this program.

When machining part A, 1 machine will additionally be involved for operation 1 and 1 machine for operation 2.

When machining part C, 1 machine will additionally be involved for operation 1.

The required number of machining centers is 5.

Washing work stations – 1 off

Inspection work stations – 1 off

Transportation pallets – 18 off

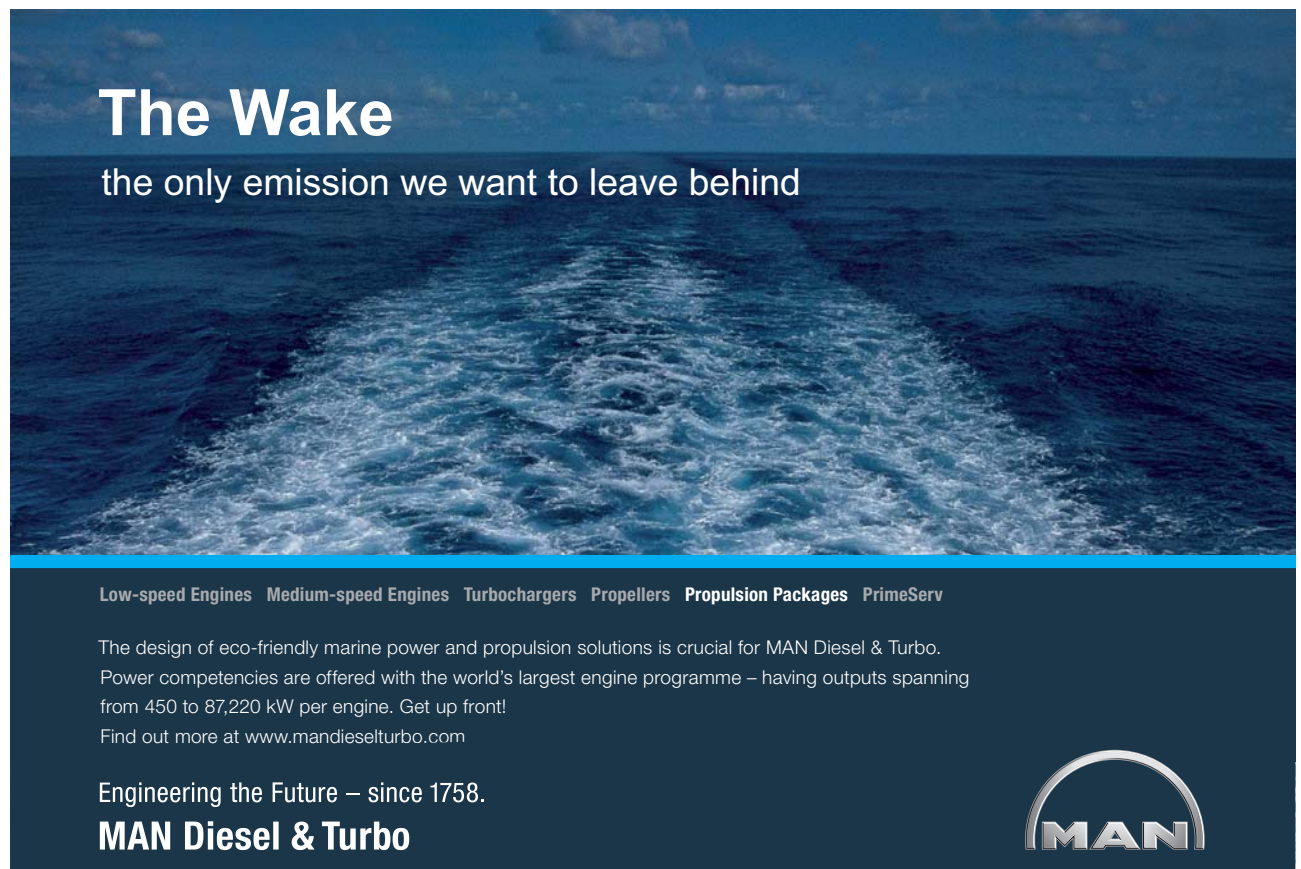

The Wake

the only emission we want to leave behind

[Low-speed Engines](#) [Medium-speed Engines](#) [Turbochargers](#) [Propellers](#) [Propulsion Packages](#) [PrimeServ](#)

The design of eco-friendly marine power and propulsion solutions is crucial for MAN Diesel & Turbo. Power competencies are offered with the world's largest engine programme – having outputs spanning from 450 to 87,220 kW per engine. Get up front!
Find out more at www.mandieselturbo.com

Engineering the Future – since 1758.
MAN Diesel & Turbo



Question 14 Plain carbon steels and high strength low alloy steels (HSLA)

- a) *Compare and contrast plain carbon steels and high strength low alloy steels (HSLA) as engineering component materials. Give examples to illustrate your answer.*

Plain carbon steels have up to 2.11 percent Carbon. The higher the content of carbon, the higher is the hardenability of the steel and the higher are its strength, hardness and wear resistance. High-strength low-alloy steels (HSLA) have been developed having low carbon content, usually less than 0.3 percent. They are characterized by a microstructure consisting of fine-grain ferrite and a hard second phase of carbides, carbonitrides or nitrides. Microalloying and controlled hot rolling produce them. They have better strength to weight ratio than carbon steels. Moreover, ductility, formability and weldability of HSLA steels are generally inferior to conventional plain carbon steels.

A comparison between basic mechanical properties for plain carbon and HSLA steels can be seen in the next page:

PLAIN CARBON STEEL	HIGH STRENGTH LOW ALLOY STEEL (HSLA)
REASONABLE HIGH STRENGTH ↑↑↑	IMPROVED STRENGTH TO WEIGHT RATIO ↑↑↑
HARDNESS ↑↑↑	DUCTILITY ↑↑↑
WEAR RESISTANCE ↑↑↑	FORMABILITY ↑↑↑
DUCTILITY ↓	WELDABILITY ↑↑↑
WELDABILITY ↓	HARDENABILITY ↓
TOUGHNESS ↓	HARDNESS ↓

Plain carbon steels are generally used for: Common industrial products such as, bolts, nuts, sheet plates, tubes. Machinery, automotive and agricultural equipment parts such as, gears, axles, connecting rods, crankshafts, railroad equipment and parts for metalworking machinery. Sheet products of HSLA steels typically are used in certain parts of automobile bodies to reduce weight and hence fuel consumption. In transportation equipment, mining, agricultural and various other industrial applications.

Plates are used in ships, bridges and building construction and shapes such as I-beams; channels and angles are used in building and various other structures.

b) Select from the materials in Table 1 below the most suitable for each of the following applications. In each case, provide full justification for the choice of materials.

- i. An aircraft component requiring maximum strength/weight ratio.
- ii. A railway locomotive component requiring maximum damage tolerance.

MATERIAL	YIELD STRENGTH(MPa)	DENSITY (Mg*m ⁻³)	K _{ic} (Mpa*m ^{-0.5})
AL-Cu-Mg-Zn Alloy	450	2.7	25
Titanium alloy	700	4.5	50
Low alloy steel 1	1,000	7.8	55
Low alloy steel 2	800	7.8	100

Table Q1: Properties of Two Alloys

- i. For an aircraft component we choose:

1. AL-Cu-Mg-Zn Alloy

ALUMINIUM [AL]
COPPER [Cu]
MAGNESIUM [Mg]
ZINC [Zn]

The choice is based on manufacturing and economic considerations.

Density of a material is its weight per unit volume [Mg*m⁻³]. The most significant role that density plays is in the Specific Strength (strength to weight ratio) of materials and structures.

THE HIGHEST OF ALL FOUR
STRENGTH/WEIGHT RATIO = 166.66

Saving weight is particularly important for aircraft and aerospace structures, their bodies and components. These products have energy consumption and power limitations as their major concerns. Substitution of materials for weight saving and economy is a major factor in advance aerospace equipment and machinery as well as in consumer products such as automobiles.

Another reason for selecting this material is the presence of Magnesium which makes the alloy very light. Density is an important factor in the selection of materials for high-speed equipment. Environmental oxidation and corrosion of components is another major concern. The exhibited corrosion resistance of Aluminium and Copper alloys gives us an additional reason for the selection of AL-Cu-Mg-Zn alloy.

Bare in mind, that, of their structural (load-bearing) components:
82 percent of a Boeing 747 aircraft
79 percent of a Boeing 757 aircraft are made of Aluminium alloys.

MECHANICAL PROPERTIES FOR THE ELEMENTS CONSISTING THE SELECTED ALLOY.
<p>ALUMINIUM:</p> <ul style="list-style-type: none"> • HIGH STRENGTH TO WEIGHT RATIO • HIGH RESISTANCE TO CORROSION BY MANY CHEMICALS • THERMAL CONDUCTIVITY • APPEARANCE • EASE OF FORMABILITY AND MACHINABILITY
<p>COPPER:</p> <ul style="list-style-type: none"> • GOOD CONDUCTORS OF ELECTRICITY AND HEAT • GOOD COROSION RESISTANCE
<p>MAGNESIUM:</p> <p>The lightest engineering metal. It is used where weight is of primary importance [alloyed with various elements to impact strength to weight ratio, not to oxidize rapidly and therefore not to become a fire hazard.]</p>
<p>ZINC:</p> <ul style="list-style-type: none"> • EASE IN PROCESSING BY FORMING, MACHINING, CASTING • CORROSION RESISTANT • THERMAL CONDUCTIVITY

ii. For the railway locomotive components the suitable material is:

Low alloy steel 2.

We selected this type of steel because, it presents a huge KIC value [$KIC = 100 \text{ Mpa} \cdot \text{m}^{0.5}$] after the yield strength value (800 Mpa). This means that, our material has a maximum damage tolerance, greater than the others' do. The yield strength value though it is quite high, it isn't higher than low alloy steel's 1 value. What we need is to acquire the biggest KIC value in the plastic deformation region. This area begins after the yield strength value, which is the border between elastic and plastic deformation.

In spite of the high density, these steels can be in suitable form for production of spare parts by suitable heat-treatment. These steels function at some static and dynamic loads-bigger of permissible, in comparison with carbon steels.

- c) **Name and discuss two alternative heat-treatment sequences to produce the properties for the low alloy steel in Table Q1.**

Appropriate heat-treatments.

1. Hardening: Heat to 850°C,
Tempering: Quench to 500°C, **oil quenched**
Isothermal transformation to upper Bainite
[Hardening and tempering at 500–600°C]
2. Hardening: Heat to 850°C,
Tempering Quench to 300°C, **in salt bath.**
Isothermal transformation to lower Bainite
[Hardening and tempering at 300°C]

Tempering

If steels are hardened by heat treatment, tempering is used in order to reduce brittleness, increase ductility and toughness and reduce residual stresses. In tempering, the steel is heated to a specific temperature, depending on composition and cooled at a prescribed rate. Alloy steels may undergo temper embrittlement caused by the segregation of impurities along the grain boundaries at temperatures between 480°C and 590°C.

In austempering, the heated steel is quenched from the austenitising temperature rapidly enough to avoid formation of ferrite or pearlite. It is then held at a certain temperature until isothermal transformation from austenite to bainite is complete. It is then cooled to room temperature usually in still air, at a moderate rate to avoid thermal gradients within the part. The quenching medium most commonly used is molten salt, at temperatures ranging from 160°C and 750°C.

Question 15 Ferritic stainless steel & the mechanism of corrosion

a) Washing machine tubs are often made from ferritic stainless steel. Discuss concisely the properties of this material, which make it suitable for this application. Name an alternative non-metallic material, which has been used, successfully for this application.

a) Ferritic stainless steels are utilized for washing machine tubs.

Chemical composition:

0.08%–0.45% Carbon

12%–27% Chromium

Properties of ferritic stainless steels

Tensile Strength: 565–620 Mpa

Yield Strength: 240–290 Mpa

Elongation: 55–60%

SMS from your computer
...Sync'd with your Android phone & number

FREE
30 days trial!

Go to
BrowserTexting.com

and start texting from your computer!

BrowserTexting

The advertisement features a laptop on the left displaying a web interface for sending SMS, and an HTC smartphone on the right showing received text messages. A blue double-headed arrow connects the two devices. The background is a light blue gradient with a dark blue diagonal banner in the top right corner.



Hardness: to 200 HRC, having a high Carbon content 0.26–0.45%, hardness will increase to 51 HRC.

Corrosion resistance: High value

Weldability: Satisfactory. Arch or gas welding.

Ferritic stainless steels can have a higher content of Cr and Ni:

Cr – [18–27%]

Ni – [3.7–5.5%]

Chromium in higher content improves Stiffness, Corrosion resistance, Machinability and Formability.

Higher Nickel content improves Strength and Toughness.

The alternative non-metallic materials, which have been used, are:

1. Polycarbonates, having very good mechanical properties and a high strength. They have low absorbability in contact with the water.
2. Polyamides
3. Fibre glass from polyester-acryl
4. Phenol-formaldehyde
5. Fiber-reinforced epoxies

- b) **Early twin-tub washing machines often suffered from corrosion failures. Explain carefully the nature and mechanism of this type of failure and state how it has been overcome in modern front loading machines.**

The nature of corrosion.

The corrosion is a surface destroying mechanism of metals and steels, as a result of a chemical and electrochemical influence of aggressive environment.

The corrosion is of two types: even and uneven.

1. Chemical corrosion appears as a result of interaction between the metal and environment (gas or non-electrolyte).
2. Electrochemical corrosion is associated with electrolyte. In this mode the character of the effect produced is electrochemical.

The mechanism of corrosion.

The atoms (ions) must receive a rather huge kinetic energy in order to tear off the surface of metal. Let's assume that the metal has dipped into the water or into a solution of acid salt (electrolyte). We have to expect that an interaction will take place between them. Water molecules will possess positive and negative electric charges and create dipoles. Dipoles will attract cations from the surface of the metal. In this way, the energy necessary for tearing one ion off the metal surface will decrease considerably and the cations will start to be transferred in the water solution. This will cause the chemical combination between water molecules and metal cations.

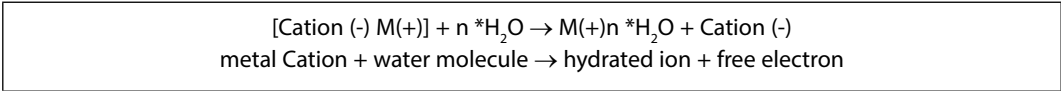

The cations will continue to be transferred into the water solution while in the metal their respective electrons won't move. Thus, creating on the border between metal and the solution a potential difference (electronic potential). The potential difference will reach the highest value when the cations will finish to tear off the surface of the metal, resulting in dynamic balance. This means that, the number of cations been transferred in the solution equals to the dehydrated and precipitated ions on the surface of the metal.

**YOUR WORK AT TOMTOM WILL
BE TOUCHED BY MILLIONS.
AROUND THE WORLD. EVERYDAY.**

Join us now on www.TomTom.jobs
follow us on **LinkedIn**



#ACHIEVEMORE **TOMTOM** 



Assuming that a double phase system is dipped into a solution of electrolyte, then two heterogeneous crystals will make a short circuit of galvanic elements. In electrolyte, the crystal, which has negative potential, will be called anode and the one that has positive will be called cathode.

Prevention of Corrosion

Ferrous alloys and steels don't corrode when they get in touch with dry air and pure water. In order to corrode electrolyte is needed to be present. The chemical pure metals corrode with more difficulty, compared to alloys. Corrosion can be transferred by contact between two metals. The metal, which will have negative potential, will corrode faster. Corrosion can be overcome in metals by alloying with other elements.

For example if we alloy:

Iron with 12%Cr – Corrosion resistance will be in low levels.

Iron with 12 to 14%Cr – Corrosion resistance in moderate to high levels.

The necessary condition in order to acquire corrosion resistance is to create homogeneous solid solutions. The alloys with 12–14%Cr are homogeneous solid solutions, which form a preventive layer to protect them from this type of failure.

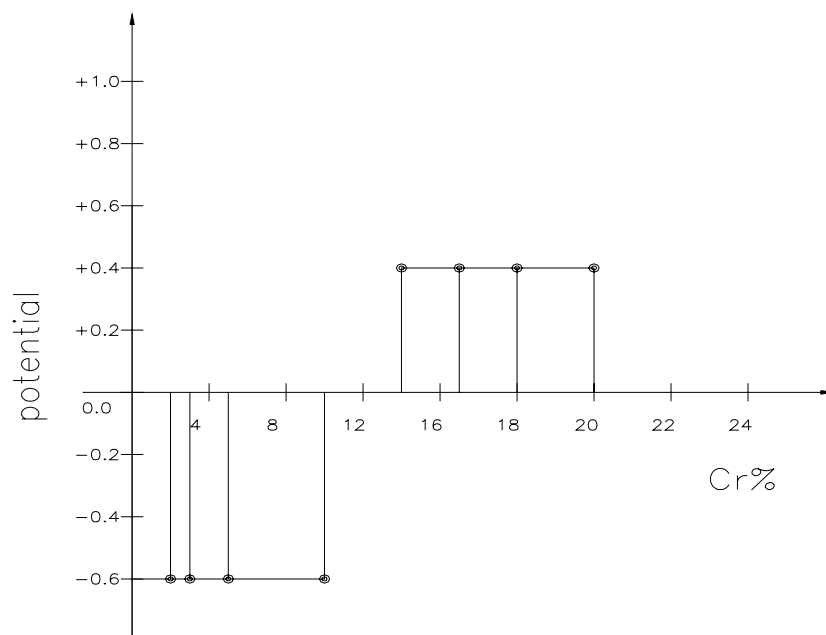

- c) **Tubs and drums for washing machines are usually manufactured from sheet metal.**
Illustrate with the aid of a flow diagram, how sheet metal is produced, commencing with the molten metal. What mechanical properties are required of the sheet and how are the final stages of the production sequence used to produce these properties?

1. Ingot raw cast iron.

2C. FLOW DIAGRAM SHOWING
PRODUCTION STAGES OF A SHEET
MATERIAL.

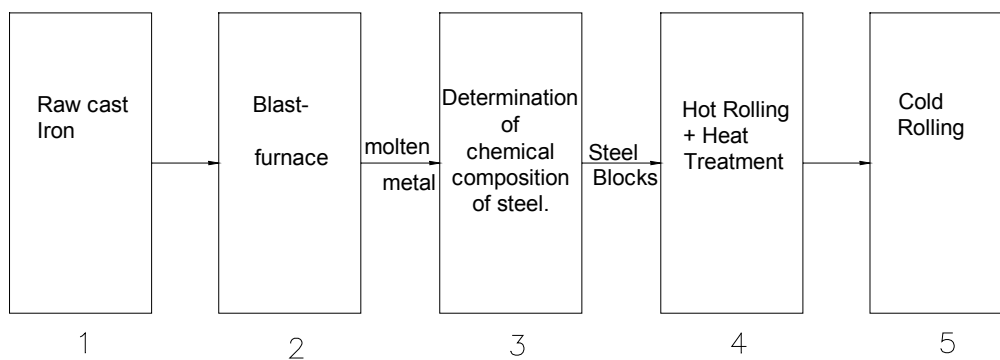

2. Blast furnace for production of molten metal.
3. Determination of chemical composition of steel: the liquid metal is manufactured by combustion of different alloys such as Silicon, Sulfur, Manganese, and Phosphorus in a convector.
4. Hot Rolling + Heat treatment: The mould is heated to a determined temperature and treated in a rolling mill. This is repeated twice. After these procedures the sheet is rolled to the desired thickness. The hot-rolled sheet has a dark exogenous surface and comparatively coarse granules. These sheets need to be annealed to acquire pure metal surface and smaller granule size.
5. Cold Rolling: The sheet is rolled rapidly at room temperature, reducing the thickness of the sheet from 5 mm gradually to 2 mm.

Question 16 Impact Strength (J) to Test Temperature

- a) Illustrate with a sketch the relationship of the Impact Strength (J) to Test Temperature, for a mild steel containing 0.2% of carbon. On the same sketch, indicate the ductile/brittle transition temperature for this steel and the effect of increasing or lowering the carbon content of the steel.

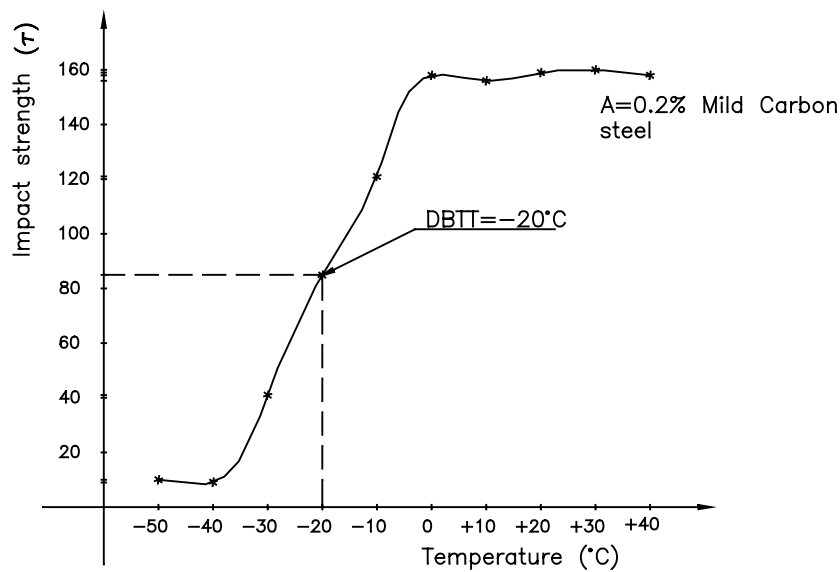

Impact Energy (Joules) for Mild Steel 0.2%C										
T°C	-50	-40	-30	-20	-10	0	+10	+20	+30	+40
MILD STEEL 0.2%C	10	9	41	85	121	158	156	159	160	158

From the graph he can acquire the below data and calculate the ductile/brittle transition temperature for our mild steel.

For A Lower energy: 10 J
 For A Higher energy: 160 J
 Total energy: $170 \text{ J} \div 2 = 85 \text{ J}$
 At 85 J related temperature is $-20 \text{ }^\circ\text{C}$
 Therefore, **DBTT = $-20 \text{ }^\circ\text{C}$**

In our mild steel:

By increasing \uparrow the C%, the DBTT will increase \uparrow .

By lowering \downarrow the C%, the DBTT will decrease \downarrow .

For example,

Mild steel: 0.2%C, 0.5%Mn, has DBTT = 0 °C

Mild steel: 0.15%C, 1.5%Mn, has DBTT = -20 to -30 °C

b) What is the practical significance of this data? Are plain carbon steels suitable for storing liquid nitrogen? If not why not and what alternative material is available?

Practical significance of Ductile/Brittle Transition Temperature measurement.

Many metals undergo a sharp change in ductility and toughness across a narrow temperature range called the transition temperature. This phenomenon occurs in body-centered cubic (bcc) and some hexagonal close-packed metals (hcp).

Face-centered cubic (fcc) metals rarely exhibit it. The transition temperature depends on factors such as composition, microstructure, grain size, surface finish and shape of the specimen and rate of deformation.



Brain power

By 2020, wind could provide one-tenth of our planet's electricity needs. Already today, SKF's innovative know-how is crucial to running a large proportion of the world's wind turbines.

Up to 25 % of the generating costs relate to maintenance. These can be reduced dramatically thanks to our systems for on-line condition monitoring and automatic lubrication. We help make it more economical to create cleaner, cheaper energy out of thin air.

By sharing our experience, expertise, and creativity, industries can boost performance beyond expectations. Therefore we need the best employees who can meet this challenge!

The Power of Knowledge Engineering

Plug into The Power of Knowledge Engineering.
Visit us at www.skf.com/knowledge

SKF

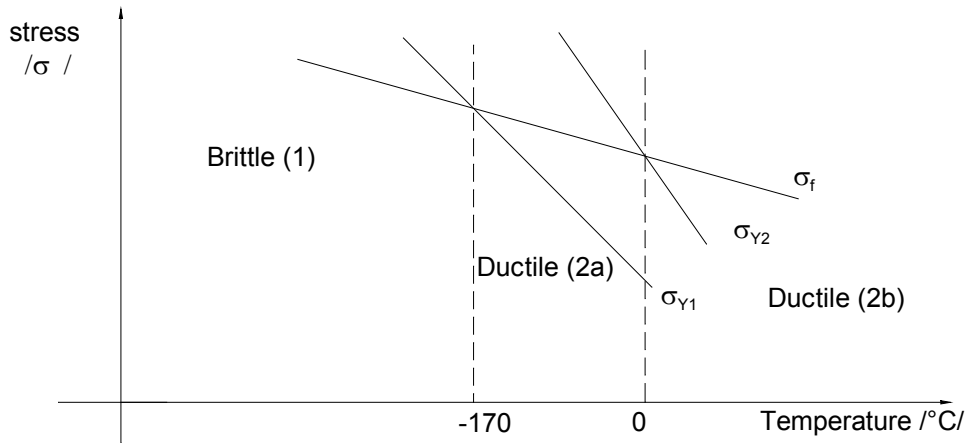

σ_f = fracture stress of 0.2% C steel
 σ_{Y1} = yield stress of 0.25 % C steel [low strain rate]
 σ_{Y2} = yield stress of 0.2 % C steel [high strain rate]

Suitable material for storing tanks.

Storing tanks made of plain carbon steel aren't in condition to store liquid nitrogen. Liquid nitrogen puts them under a high amount of pressure, which acts, on the walls of the storing tank. Under these conditions, Nitrogen is dissolved in the Iron and produces Fe_4N . This new synthesis accelerates the operating life of these soft steels. It makes the material to grow old quickly reducing its strength property. It also lowers hardness against fatigue, because of tensions, which has created in lattices.

There is an opportunity to make a detachment of nitrides at the limits of the grains and on the relaying planes with a speed, which concurs with the speed of the loading. In other words there is a condition for an artificial acceleration in operating life, which accompanies plastic deformation.

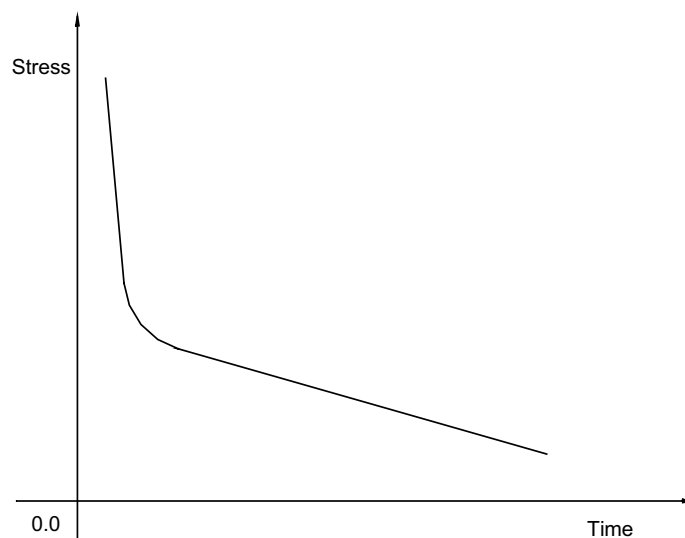

A suitable alternative material for storing tanks.

It is preferable to use High-speed steels (HSS), and alloy them with non-ferrous elements such as Aluminium, Titanium and Nitrogen. These steels have excellent intercrystal corrosion, thus high corrosion resistance properties.

- c) **Discuss carefully how one could distinguish whether a steel shaft had experienced brittle fracture or fatigue failure?**

One could easily distinguish whether a steel shaft had experienced fatigue failure or brittle fracture.

Fatigue failure

Fatigue is responsible for the majority of failures in mechanical components. Basically, shafts, cams and gears are subjected to rapidly fluctuating (cyclic or periodic) loads, in other words, rotations and severe vibrations. Minute external or internal cracks develop at flaws or defects in the material, which then propagate and eventually lead to total failure. We could distinguish fatigue in our steel shaft by the typical fatigue fracture surface showing beach marks. With large magnification, a series of striations can be seen on fracture surfaces, each beach mark consisting of a number of striations.



> Apply now

REDEFINE YOUR FUTURE
**AXA GLOBAL GRADUATE
PROGRAM 2015**

redefining / standards 

agence.cdg. © Photomostop



Furthermore, fatigue can be identified by the endurance or fatigue limit. On the below, stress – number of cycles (N), this curve shows, the maximum stress to which the material can be subjected without fatigue failure, regardless of the number of cycles. Any failure below this limit would be considered as other type of failure because there is no fatigue failure occurring below this curve. The fatigue limit for steels is about one-half ($\frac{1}{2}$) of their tensile strength. Especially, steels have a definite fatigue limit, while other metals do not have one.

Brittle fracture

Brittle fracture will occur with little or no gross plastic deformation. In our steel it could be identified by the rapid separation of the material into two or more pieces. Brittle fracture mostly occurs under static loads.

d) How may the toughness and tensile strength of brittle thermosets such as PF resin (Bakelite) be increased?

In thermoplastics the typical effects of temperature on the strength, the stiffness and toughness are similar to those for metals. Thus, with increasing temperature, the strength and the stiffness decrease and toughness increases.

Because of the nature of their bonds, temperature or rate of deformation doesn't affect the strength, stiffness and toughness of thermosets unlike thermoplastics. Moreover, if the temperature is increased sufficiently, the thermosetting begins to burn up and char.

Strength, stiffness and toughness will increase, if we reinforce the thermoset with fibers. Reinforced thermosets consist of fibers (the discontinuous or dispersed phase). The fibers are strong and stiff and have high specific strength (strength to weight ratio) and specific modulus (stiffness to weight ratio). However, they are generally brittle and abrasive and lack toughness. Thus, fibers themselves have little structural value. The thermosetting matrix is less strong and less stiff but tougher than the fibers. Thus, reinforced thermosets combine the advantages of each of the two constituents. In addition to high specific strength and specific modulus, reinforced thermosets have improved toughness and creep resistance than unreinforced thermosets.

Question 17 Metal and polymer material applicability

- a) Compare and contrast metals and polymers for use in **THREE** of the following applications. In each case suggest **TWO** suitable materials, **ONE** a metal and a polymer.
- v. 300 mm ruler
 - vi. Small rectangular instrument case
 - vii. Office or restaurant chair legs

For the 300-mm ruler we have selected:

Polymer: Acrylonitrile-butadiene-styrene (ABS). It is dimensionally stable and rigid and has good impact, abrasion and chemical resistance. It has also, high strength, toughness, low temperature properties and electrical resistance.

Metal: Aluminium (Al). The important factors in selecting Aluminium are its high strength to weight ratio, resistance to corrosion by many chemicals, high thermal and electrical conductivity, nontoxicity, reflectivity, appearance. Ease of formability and machinability. Aluminium is also nonmagnetic.

LIGS University
based in Hawaii, USA

is currently enrolling in the
Interactive Online **BBA, MBA, MSc,**
DBA and PhD programs:

- ▶ enroll **by October 31st, 2014** and
- ▶ **save up to 11%** on the tuition!
- ▶ pay in 10 installments / 2 years
- ▶ Interactive Online education
- ▶ visit www.ligsuniversity.com to find out more!

Note: LIGS University is not accredited by any nationally recognized accrediting agency listed by the US Secretary of Education. More info [here](#).





For the rectangular instrument case we have selected:

Polymer: Polystyrene (PS). Polystyrenes are inexpensive materials. They have generally average strength, toughness, chemical and electrical resistance. They are somewhat brittle.

Metal: Low carbon steel. It has less than 0.3% carbon. It is generally used for common industrial products that don't require high strength, hardness and wear resistance.

Office or restaurant chair legs. For this application we have chosen:

Polymer: ABS Reinforced. It has higher values of strength and stiffness than unreinforced ABS. It is therefore, more stable and rigid and suites the purpose of selection for this application.

Metal: Ferritic stainless steel. This type of stainless steel has a high chromium content: up to 27%. It has good strength and impact toughness. It is magnetic and has good corrosion resistance. In comparison with austenitic stainless steel has lower ductility. Ferritic stainless steel is hardened by cold working and is generally used for non-structural applications such as kitchen and office equipment.

Applications		300 mm Ruler		Small rectangular instrument case		Office or restaurant chair legs	
Suitable materials		ABS	Aluminium	Polystyrene	Low Carbon steel	ABS Reinforced	Ferritic Stainless steel
Physical	Density-weight	Light	light	light	Reasonably heavy	light	Reasonably heavy
	Dimensional stability	high	high	low	moderate	high	high
	Electrical resistivity	moderate	high	high	high	high	high
	Corrosion resistance-degradation	moderate	high	moderate	moderate	moderate	high
Mechanical	Tensile Strength	moderate	high	low	low	high	high
	Stiffness	high	high	low	low	moderate	moderate
	Impact Toughness	low	moderate	low	low	moderate	moderate
	Resistance to Wear	low	moderate	low	low	moderate	moderate
Appearance	Surface finish, Texture	excellent	excellent	excellent	excellent	excellent	excellent

- b) Choose one of the components already selected and name and justify manufacturing processes for the metal and polymer versions respectively.

We choose the 300-mm ruler and undertake an analysis in the manufacturing processes for the metal and polymer versions respectively.

Aluminium ruler

Rolling: The process of reducing the thickness or changing the cross-section of our workpiece by compressive forces applied through a set of rolls similar to rolling dough with a rolling pin to reduce its thickness. Our operation is flat rolling where, the rolled products are flat sheets (ruler thickness less than 3 mm).

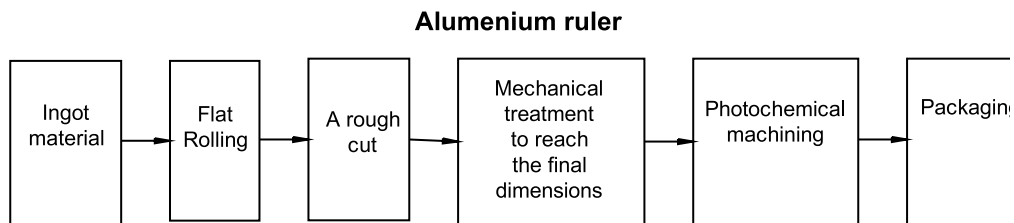

Photochemical machining: This process (similar to stereo lithography) uses two laser beams intersecting each other to form the part. One beam moves in the X-Y plane and the other in the X-Z plane. Thus part production is more versatile and no longer done in layers.

Acrylonitrile-butadiene-styrene (ABS) ruler

Injection molding is essentially the same process as hot-chamber die-casting. The pellets or granules are fed into a heated cylinder, where they are melted. The melt is then forced into a split-die chamber, either by a hydraulic plunger or by the rotating screw system of an extruder. Newer equipment is of the reciprocating screw type. As the pressure builds up at the mold entrance, the rotating screw begins to move backward under pressure to a predetermined distance, thus controlling the volume of material to be injected. The screw stops rotating and is pushed forward hydraulically, forcing the molten plastic into the mold cavity. Injection molding pressures usually range from 70 Mpa to 200 Mpa, which is in the same order of magnitude as in cold-chamber die-casting.

Because the material is molten when injected into the mold, complex shapes and good dimensional accuracy can be achieved, as in die-casting. However, as in metal casting, the molded part shrinks during cooling. Plastics have a higher thermal expansion than metals.

Injection molding is a high-rate production process, with good dimensional control. Typical cycle times range from 5 to 60 seconds.

Acrylonitrile – butadiene – styrene (ABS) Ruler

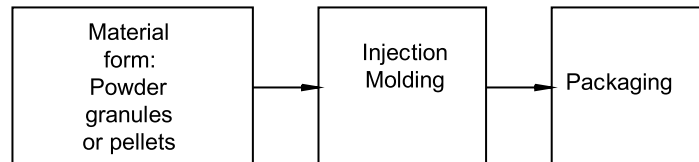

TURN TO THE EXPERTS FOR **SUBSCRIPTION** CONSULTANCY

Subscribe is one of the leading companies in Europe when it comes to innovation and business development within subscription businesses.

We innovate new subscription business models or improve existing ones. We do business reviews of existing subscription businesses and we develop acquisition and retention strategies.

Learn more at [linkedin.com/company/subscribe](https://www.linkedin.com/company/subscribe) or contact
Managing Director Morten Suhr Hansen at mha@subscribe.dk

SUBSCR✓**BE** - to the future

Question 18 Maximum tolerable through thickness crack size

- a) **Steam turbine blades are manufactured from austenitic stainless steel. Determine the maximum tolerable through thickness crack size for the components and state any assumptions made. Name and justify a suitable non-destructive technique to locate such cracks.**

$$\sigma(\text{Operating stress}) = 300 \text{ Mpa}; K_{IC} = 50 \text{ Mpa}\cdot\text{m}$$

In this case we use the Stress Intensity factor K_{IC} for center crack length $2a$ in an infinitive plate. This factor it is given by the formula:

$$K_{IC} = \sigma_F (\pi \cdot a_C)^{1/2}$$

,where $\sigma_F \Rightarrow$ operating stress;
 $a_C = 1/2$ critical crack length.

We transform the formula to get:

$$a_C = \left(\frac{K_{IC}}{\sigma_F} \right)^2 \cdot \frac{1}{\pi}$$

$$a_C = \left(\frac{50}{300} \right)^2 \cdot 0,31847$$

$$a_C = 8,846 \cdot 10^{-3} \text{ m}$$

$$\text{Critical crack } 2a_C = 17,69 \cdot 10^{-3} \text{ m}$$

through thickness crack size for the component.

Firstly, let's see which techniques don't work for the detection of our flaw:

Dye penetration technique.

This method can only detect defects that are open on the surface, not internal defects such as the one we have.

Magnetic particle inspection technique.

This method is appropriate primarily for surface breaking defects and discontinuities not more than 10 mm below the surface of the component. Our through crack size is = 17.7 mm.

Eddy-current inspection method.

Again, and this method is limited to surface and slightly sub surface flaws.

Radiography

The smallest defect that can be detected is 2% of thickness. The process becomes less reliable as the section thickness increases. In this respect it is a disadvantage compared with ultrasonic testing which can detect small flaws in steel up to 15 meters thick. Other disadvantages are: costly equipment, potential radiation and leakage hazard. The suitable non-destructive technique that we have chosen is the Ultrasonic Inspection method.

Ultrasonic Inspection

In Ultrasonic Inspection, an ultrasonic beam travels through the part, is interrupted from an internal defect and reflects back a portion of the ultrasonic energy. This method is suitable for our case, because it can be used to inspect flaws in surface and in large volumes of materials (deep flaws). It has also, penetrating power and sensitivity, thus high accuracy.

- b) **During service, the blades described in a) must not suffer an axial strain of more than 0.001. Using table Q4.1 below, determine the maximum operating temperature of the blades, if a service life of at least 10,000 hours is required.**

Operating temperature (°C)	480	500	520	540	560
Strain rate/hour	1.2*10 ⁻⁸	2.5*10 ⁻⁸	4.4*10 ⁻⁸	8.2*10 ⁻⁸	1.6*10 ⁻⁷

Table Q4.1: Creep data for austenitic stainless Steel.

Firstly, we need to find the appropriate strain rate * hour⁻¹ value using formula A and then link it to the maximum operating temperature.

A	strain rate . hour⁻¹ . Service life = axial strain
----------	--

Our conditions are:

Maximum axial strain value = 0,001 = 10^{-3}

Maximum service life value = 10000 hours = 10^4 hours

Using, strain rate * hour⁻¹ = $8,2 \cdot 10^{-8}$ we receive:

$8,2 \cdot 10^{-8} \cdot 10000 = 0,00082$

Which, is an acceptable value for axial strain.

In order to find a strain value of 0.001, we need to determine the exact service life value. Manipulating formula A, we receive:

$\frac{\text{axial strain}}{\text{strain rate} \cdot \text{hour}^{-1}} = \text{service life}$	$\frac{0,001}{8,2 \cdot 10^{-8}} = 12,195 \text{ hours}$
---	--

The above number satisfies the second condition we have been given. Using, these service life values into formula A we get:

$$8,2 \cdot 10^{-8} \cdot 12,195 = 0,001 \text{ axial strain}$$

Thus, satisfying the first condition, by keeping axial strain 0.001 as our maximum axial strain value. We have determined:

$\text{strain rate} \cdot \text{hour}^{-1} = 8,2 \cdot 10^{-8}$ $\text{Service life} = 12,195 \text{ hours}$
--

Using the above strain rate * hour⁻¹ value we accept that the maximum operating temperature is:

$T = 540 \text{ }^{\circ}\text{C}$

- c) A dentist's drill rotates at 4,000 revolutions per second (rps). The drill has experienced the service history shown in table Q4.2 below. Using Miner's rule (the cumulative damage law), estimate the remaining life expectancy of the drill in seconds, if it is operated at a stress range of 350 Mpa. Hence determine whether or not the drill bit should be changed before the next operation, which requires an estimated drilling time of 30 seconds.

Stress Range (Mpa)	250	300	350
N (cycles)	$1 * 10^9$	$1 * 10^8$	$1 * 10^7$
N(cycles)	$1 * 10^9$	$1 * 10^7$	$5 * 10^6$

Table Q4.2: The Service History of a Dentist's Drill

Miner's Rule [the cumulative damage law]

$$\sum \frac{n}{N} = 1$$

"I studied English for 16 years but...
...I finally learned to speak it in just six lessons"
Jane, Chinese architect

ENGLISH OUT THERE

Click to hear me talking before and after my unique course download



Where, n = number of stress cycles; N = number of stress cycles to cause failures.

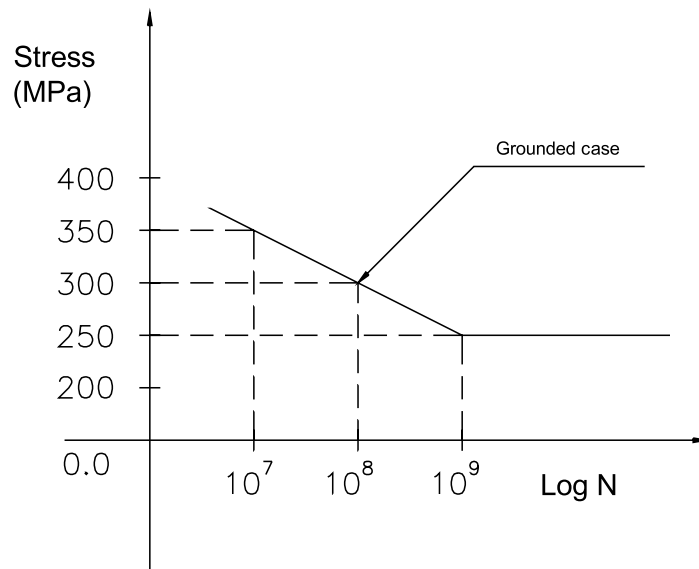

$$\frac{n_1}{N_1} + \frac{n_2}{N_2} + \frac{n_3}{N_3} + \frac{n_4}{N_4} = 1$$

$$\frac{10^8}{10^9} + \frac{10^7}{10^8} + \frac{10^6}{10^7} + \frac{n_4}{10^7} = 1$$

$$n_4 = (1 - 0,1 - 0,1 - 0,1) \cdot 10^7$$

$$n_4 = 0,7 \cdot 10^7 = 7000000$$

The speed of the drill is 4000 rev/sec

$$\frac{7000000}{4000} = 1750 \text{ sec} = 29,17 \text{ min} \quad \boxed{\text{life expectancy} = 1750 \text{ sec}}$$

Therefore, the drill bit shouldn't be changed before the next 30 sec operation because the remaining life expectancy is a huge number compared with the drilling time.

Question 19 Glass fibres production–Reinforced composite design

- a) Describe concisely how glass fibres are produced and how and why they are protected from surface damage. Using the data below, determine the maximum flaw size to ensure a minimum glass fibre tensile strength of 2,200 Mpa.

$$E = 100 \text{ Gpa}; \quad \gamma = 0.8 \text{ J} \cdot \text{m}^{-2}$$

Glass fibers are the most widely used and least expensive of all fibers. The composite material is called glass-fiber reinforced plastic (GFRP) and may contain between 30% and 60% glass fibers by volume. Drawing molten glass through small openings in platinum dies makes Glass fibers.

Continuous fibers are drawn through multiple (200–400) orifices in heated platinum plates at speeds as high as 500 m/s. Fibres as small as 2µm in diameter can be produced by this method.

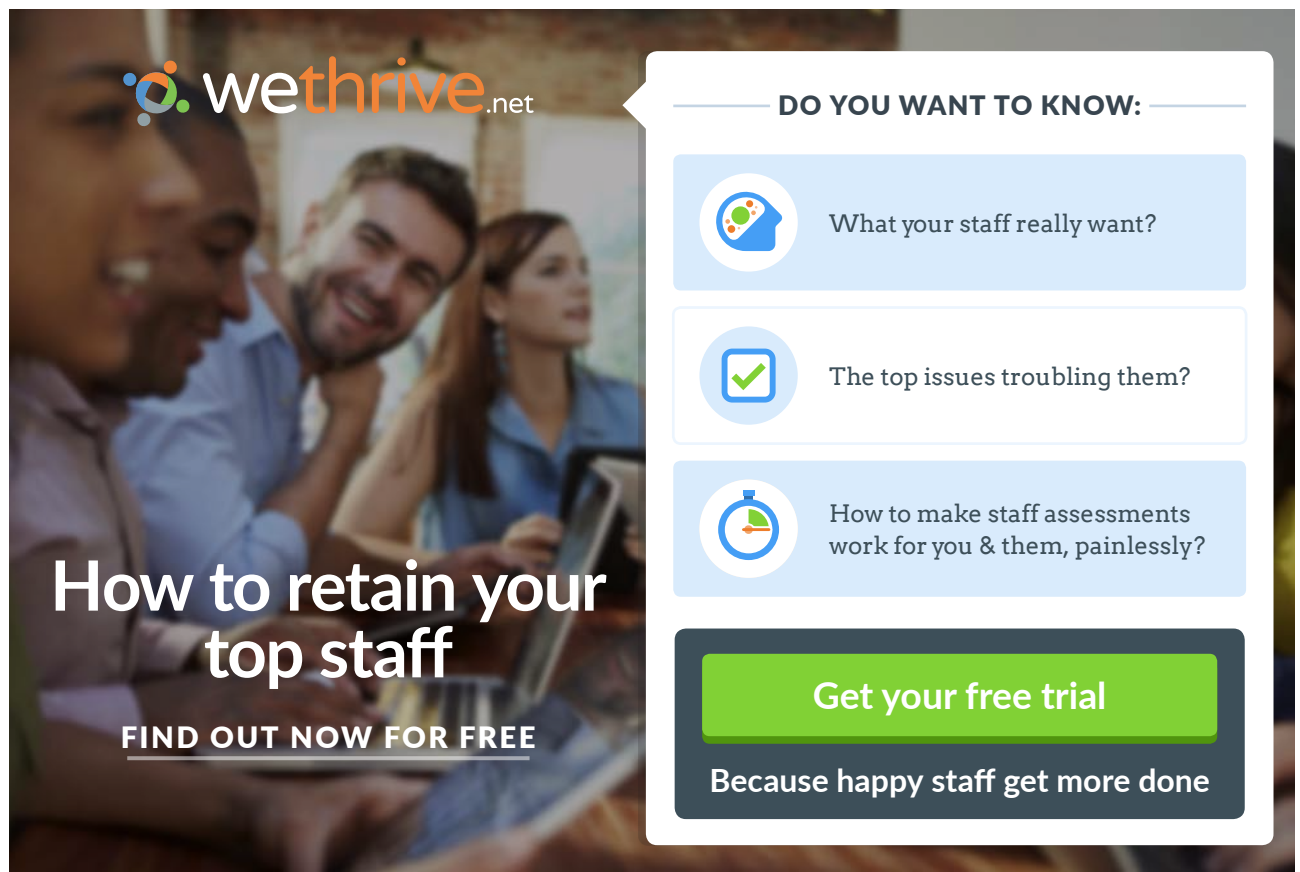

wethrive.net

How to retain your top staff

FIND OUT NOW FOR FREE

DO YOU WANT TO KNOW:

- What your staff really want?
- The top issues troubling them?
- How to make staff assessments work for you & them, painlessly?

Get your free trial

Because happy staff get more done



In order to protect their surfaces, the fibers are subsequently coated with chemicals. Surface treatment may be necessary to:

- Impart color or special surface texture
- Improve corrosion and oxidation resistance
- Improve stiffness and fatigue resistance

Griffith's Crack Criteria formula:

$$\sigma_F = \left[\frac{2 \cdot \gamma \cdot E}{\pi \cdot a} \right]^{1/2},$$

where $\sigma_F \Rightarrow$ critical stress for crack propagation, [N.m⁻²];

$\gamma \Rightarrow$ surface energy or work of Fracture, [J.m⁻²];

$E \Rightarrow$ Young's Modulus or Modulus of Elasticity, [N.m⁻²];

$\pi = 3,14$;

$a \Rightarrow$ crack depth, [m].

glass fibre tensile strength $\sigma_F = 2200 \text{ MPa} = 2,2 \text{ GPa} = 2,2 \cdot 10^9 \text{ N.m}^{-2}$

surface energy $\gamma = 0,8 \text{ J.m}^{-2}$

Young's Modulus $E = 100 \text{ GPa} = 100 \cdot 10^9 \text{ N.m}^{-2}$

First resolution

$$2,2 \cdot 10^9 = \sqrt{\frac{2 \cdot 0,8 \cdot 100 \cdot 10^9}{\pi \cdot a}} = \frac{\sqrt{2 \cdot 0,8 \cdot 100 \cdot 10^9}}{\sqrt{\pi \cdot a}}$$

$$(\sqrt{a})^2 = \left(\frac{\sqrt{2 \cdot 0,8 \cdot 100 \cdot 10^9}}{\sqrt{\pi \cdot 2,2 \cdot 10^9}} \right)^2$$

$$a = \frac{2 \cdot 0,8 \cdot 100 \cdot 10^9}{\pi \cdot (2,2 \cdot 10^9)^2} = \frac{2 \cdot 0,8}{3,14 \cdot 2,2^2 \cdot 10^7} = \frac{1,6}{3,14 \cdot 4,84 \cdot 10^7}$$

$$a = 0,105 \cdot 10^{-7}$$

$$a = 10,5 \cdot 10^{-9} \text{ m} = 10,5 \cdot 10^{-6} \text{ mm}$$

Second resolution

$$(2,2 \cdot 10^9)^2 = \frac{2 \cdot 0,8 \cdot 100 \cdot 10^9}{3,14 \cdot a}$$

$$a = \frac{1,6 \cdot 100 \cdot 10^9}{3,14 \cdot 4,84 \cdot (10^9)^2} = \frac{1,6 \cdot 100}{3,14 \cdot 4,84 \cdot 10^9} = 10,5 \cdot 10^{-9} \text{ mm}$$

- b) Using the data below, design an uniaxially reinforced composite, exhibiting a minimum axial tensile strength of 1,000 Mpa and a minimum axial Young's modulus (E) of 40 Gpa. Maximum marks will be awarded for an economic design.

Material	E(Gpa)	Tensile strength (Mpa)	Cost (L/Kg)
Resin matrix	2	60	1
Glass fibre	100	2200	4

Substituting the exhibited minimum axial tensile strength of 1,000 Mpa into the stress σ_c formula we get:

$$\begin{aligned}\sigma_c &= p[\sigma_F \cdot V_F + \sigma_m \cdot (1 - V_F)] \\ \sigma_c &= 1000 = 1 \cdot [2200 \cdot V_F + 60 \cdot (1 - V_F)] \\ (2200 - 60) \cdot V_F &= 1060 \\ 2140 \cdot V_F &= 1060 \\ V_F &= \frac{1060}{2140} = 0,495 \text{ m}^3 \\ V_m &= 1 - 0,495 = 0,505 \text{ m}^3\end{aligned}$$

We have to ensure that Young's Modulus E has a minimum value of 40 Gpa. Thus, we substitute into the Modulus of Elasticity formula:

$$\begin{aligned}E_c &= p[E_F \cdot V_F + E_m \cdot (1 - V_F)] \\ E_c &= 1 \cdot [100 \cdot 0,495 + 2 \cdot (1 - 0,495)] = 100 \cdot 0,495 + 2 \cdot 0,505 \\ E_c &= 49,5 + 1,01 \\ E_c &= 50,51 \text{ GPa}\end{aligned}$$

Our design costs:

$$V_F = 0,495 \text{ m}^3; \quad V_m = 0,505 \text{ m}^3$$

Our cost is in L/Kg and our volume values V_f and V_m are in m^3 . We know that:
1 Kg = 1 dm^3 and 1 m^3 = 1000 dm^3 .

Therefore, our design will cost:

$$V_F = 0,495 \cdot 1000 \Rightarrow V_F = 495 \text{ dm}^3$$

$$V_m = 0,505 \cdot 1000 \Rightarrow V_m = 505 \text{ dm}^3$$

$$495 \cdot 4 \text{ €} = 1980 \text{ € /dm}^3$$

$$505 \cdot 1 \text{ €} = 505 \text{ € /dm}^3$$

$$\Sigma = 2485 \text{ € /dm}^3$$

The uniaxial reinforced composite design is presented below.

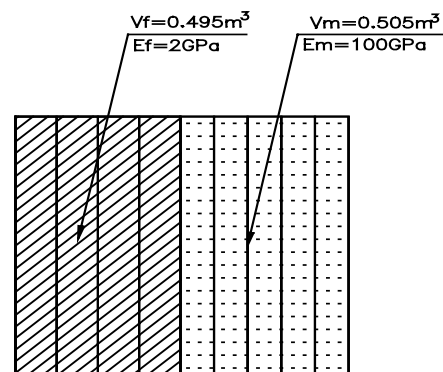
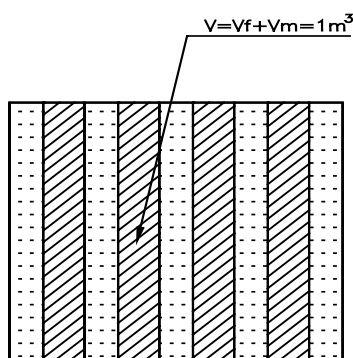

gaiteye
Challenge the way we run

**EXPERIENCE THE POWER OF
FULL ENGAGEMENT...**

**RUN FASTER.
RUN LONGER..
RUN EASIER...**

**READ MORE & PRE-ORDER TODAY
WWW.GAITEYE.COM**

- c) **The composite designed in b) may contain small air bubbles in the resin. What effect is this likely to have on the overall properties of the composite?**

The presence of bubbles in the resin results to a local increase of tension, which is caused by the sudden change in the structure. The matrix in reinforced composites has three functions:

1. Support and transfer the stresses to the fibers, which carry most of the load.
2. Protect the fibers against physical damage and environmental corrosion.
3. Reduce propagation of cracks in the composite by virtue of the ductility and toughness.

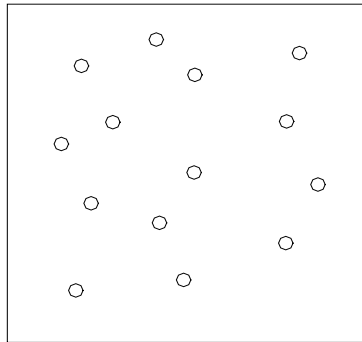

The presence of bubbles causes a weak strength of the bond between the fiber and the polymer matrix. Thus, our composite under static loading will present fiber pullout and delamination of the structure, particularly under adverse environmental conditions. The presence of bubbles reduces ductility and toughness of the composite, which means that, under static loading (transmitted through the fiber-matrix interface) the structure is expected to fail (brittle failure). This case is analogous to opening holes in a brick structure. It causes poor bonding between the bricks and the mortar. Under loading and extensive tension along the surface the structure collapses.

References

1. K.L. Edwards. Designing of engineering components for optimal materials and manufacturing process utilisation. *Materials & Design*, Volume 24, Issue 5, August 2003, Pages 355-366.
2. M.V. Gandhi, B.S. Thompson, F. Fischer. Manufacturing-process-driven design methodologies for components fabricated in composite materials. *Composites Manufacturing*, Volume 1, Issue 1, March 1990, Pages 32-40.
3. M. Jahazi, S. Hossein-Nejad. The development of an optimum manufacturing and material selection process for the fabrication of labyrinth seal strips. *Journal of Materials Processing Technology*, Volume 152, Issue 3, 30 October 2004, Pages 272-275.
4. P. Eyerer, B. Wiedemann, K.-H. Dusel, B. Keller. Materials for solid freeform manufacturing processes. *Computers in Industry*, Volume 28, Issue 1, December 1995, Pages 35-45.
5. Yong-Min Kwak, Charalabos C. Doumanidis. Geometry Regulation of Material Deposition in Near-Net Shape Manufacturing by Thermally Scanned Welding. *Journal of Manufacturing Processes*, Volume 4, Issue 1, 2002, Pages 28-41.
6. K.P. Karunakaran, S. Suryakumar, Vishal Pushpa, Sreenathbabu Akula. Low cost integration of additive and subtractive processes for hybrid layered manufacturing. *Robotics and Computer-Integrated Manufacturing*, Volume 26, Issue 5, October 2010, Pages 490-499.
7. B. Gopalakrishnan, V. Pandiarajan. Materials and manufacturing processes selection system for product designs in concurrent engineering. *Journal of Materials Processing Technology*, Volume 28, Issues 1-2, September 1991, Pages 93-103.
8. M. Perzyk, O.K. Meftah. Selection of manufacturing process in mechanical design. *Journal of Materials Processing Technology*, Volume 76, Issues 1-3, April 1998, Pages 198-202.
9. F. Liu, H. Zhang, P. Wu, H.J. Cao. A model for analyzing the consumption situation of product material resources in manufacturing systems. *Journal of Materials Processing Technology*, Volume 122, Issues 2-3, 28 March 2002, Pages 201-207.
10. Shaw C. Feng, Eugene Y. Song. A manufacturing process information model for design and process planning integration. *Journal of Manufacturing Systems*, Volume 22, Issue 1, 2003, Pages 1-15.
11. I. Ferrer, J. Rios, J. Ciurana. An approach to integrate manufacturing process information in part design phases. *Journal of Materials Processing Technology*, Volume 209, Issue 4, 19 February 2009, Pages 2085-2091.
12. M.V. Gandhi, B.S. Thompson, F. Fischer. Manufacturing-process-driven design methodologies for components fabricated in composite materials. *Materials & Design*, Volume 11, Issue 5, October 1990, Pages 235-242.
13. M. Hou, L. Ye, Y.W. Mai. Manufacturing process and mechanical properties of thermoplastic composite components. *Journal of Materials Processing Technology*, Volume 63, Issues 1-3, January 1997, Pages 334-338.

14. C.J. Luis Pérez, J. Vivancos Calvet, M.A. Sebastián Pérez. Geometric roughness analysis in solid free-form manufacturing processes. *Journal of Materials Processing Technology*, Volume 119, Issues 1–3, 20 December 2001, Pages 52–57.
15. Shu-Kai S. Fan, Yen Lin. Multiple-input dual-output adjustment scheme for semiconductor manufacturing processes using a dynamic dual-response approach. *European Journal of Operational Research*, Volume 180, Issue 2, 16 July 2007, Pages 868–884.
16. Elvin Karana, Paul Hekkert, Prabhu Kandachar. Meanings of materials through sensorial properties and manufacturing processes. *Materials & Design*, Volume 30, Issue 7, August 2009, Pages 2778–2784.
17. A.M. Lovatt, H.R. Shercliff. Manufacturing process selection in engineering design. Part 1: the role of process selection. *Materials and Design*, Volume 19, Issues 5–6, 17 December 1998, Pages 205–215.
18. S.H. Choi and, H.H. Cheung. A topological hierarchy-based approach to toolpath planning for multi-material layered manufacturing. *Computer-Aided Design*, Volume 38, Issue 2, February 2006, Pages 143–156.
19. W.B. Lee, C.F. Cheung, J.G. Li. Applications of virtual manufacturing in materials processing. *Journal of Materials Processing Technology*, Volume 113, Issues 1–3, 15 June 2001, Pages 416–423.
20. S. Kalpakjian. *Manufacturing processes for engineering materials*: Addison Wesley Publishing Company, Reading, Ma. 1984, 839 pp.
21. R.E. Kirchain. Cost Modeling of Materials and Manufacturing Processes. *Encyclopaedia of Materials: Science and Technology*, 2008, Pages 1718–1727.

Endnotes

* Q – queue

** A – activity

This e-book
is made with
SetaPDF



SETASIGN

PDF components for **PHP** developers

www.setasign.com

