

Fundamentals of Chemistry Part II

Romain Elsair



Download free books at

bookboon.com

Romain El Sair

Fundamentals of Chemistry Part II

Fundamentals of Chemistry Part II

1st edition

© 2014 Romain El Sair & bookboon.com

ISBN 978-87-403-0746-7

Contents

1	Electrochemistry	8
1.1	Energy Transfer	8
1.2	Applications of Electro-chemistry	8
1.3	Electro-chemical Cells	8
1.4	Effect on electrodes	11
1.5	Half-cell redox reactions	12
1.6	Anode and Cathode	12
1.7	Electro-chemical Cell Notation	12
1.8	Example	15
1.9	Exercise	15
1.10	Potential Difference	16
1.11	Example	19
1.12	Standard Electrode Potentials	19
1.13	Example	22
1.14	Exercise	23



Discover the truth at www.deloitte.ca/careers

Deloitte.

© Deloitte & Touche LLP and affiliated entities.



Click on the ad to read more

2	Electrochemistry (2)	24
2.1	Predicting Reactions	24
2.2	Strengths of Oxidising and Reducing Agents	25
2.3	Rusting	27
2.4	Some Commercial Electrochemical Cells	27
2.5	Electrolytic Cell	30
2.6	Electrolysis of Molten Salts	31
2.7	Calculation Examples	34
2.8	Example	34
3	Chemical Equilibrium	36
3.1	Reversible Reactions	37
3.2	Reactions in a closed system	37
3.3	Haber's process	39
3.4	The equilibrium constant	40
3.5	Equilibrium law for heterogeneous reactions	43

© 2013 Accenture. All rights reserved.

be > your degree

Bring your talent and passion to a global organization at the forefront of business, technology and innovation. Discover how great you can be.

Visit accenture.com/bookboon

Be greater than.
consulting | technology | outsourcing

accenture
High performance. Delivered.



3.6	Obtaining equilibrium constant expressions	43
3.7	Units of equilibrium constants	45
3.8	Calculating equilibrium concentrations	45
3.9	General steps to follow	47
3.10	Equilibrium constant for the sum of reactions	48
4	Chemical Equilibrium (2)	50
4.1	The Equilibrium Constant, K_p	51
4.2	Le Chatelier's principle	54
4.3	Manipulating yields	58
5	Acids and Bases	60
5.1	Reactions of acids	60
5.2	Acid-Base theories	61
5.3	Self-ionisation of water	67
5.4	Solutions of Strong Acid or Base	69

The Wake

the only emission we want to leave behind

[Low-speed Engines](#) [Medium-speed Engines](#) [Turbochargers](#) [Propellers](#) [Propulsion Packages](#) [PrimeServ](#)

The design of eco-friendly marine power and propulsion solutions is crucial for MAN Diesel & Turbo. Power competencies are offered with the world's largest engine programme – having outputs spanning from 450 to 87,220 kW per engine. Get up front! Find out more at www.mandieselturbo.com

Engineering the Future – since 1758.

MAN Diesel & Turbo



6	Thermochemistry	74
6.1	Thermo-chemical Equations	74
6.2	Hess's Law	75
6.3	Enthalpy diagram	76
6.4	Calculating the Enthalpy change of a reaction	76
6.5	Enthalpy diagram	78
6.6	Lattice Enthalpy	78
6.7	Born-Haber Cycles	80

SMS from your computer

...Sync'd with your Android phone & number

FREE
30 days trial!

Go to

BrowserTexting.com

and start texting from
your computer!

 **BrowserTexting**

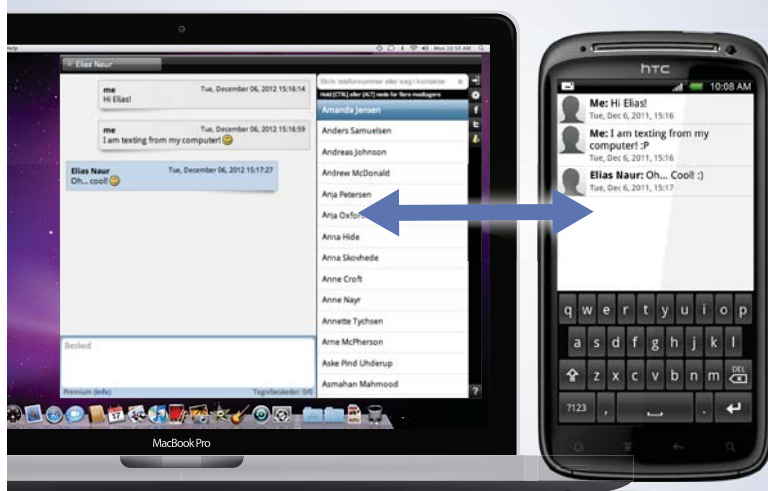

1 Electrochemistry

Learning points

- Introduction to the concept of energy transfer
- Commercially available electro-chemical cells
- Understand and recognise electro-chemical equations
- Differentiate between Cathode / Anode and Reduction / Oxidation reactions
- Introduction to potential difference between cells

1.1 Energy Transfer

Reduction / Oxidation (also called “Redox”) reactions, like all other chemical reactions, have an associated enthalpy change. If the reactants are mixed in direct contact, then this enthalpy change would be seen as release (or intake) of heat. If the reactants are physically separated, but are connected via an external circuit, then an electric current is generated instead.

1.2 Applications of Electro-chemistry

The applications of these reactions range from the lead-acid batteries in cars to torch batteries as seen below.

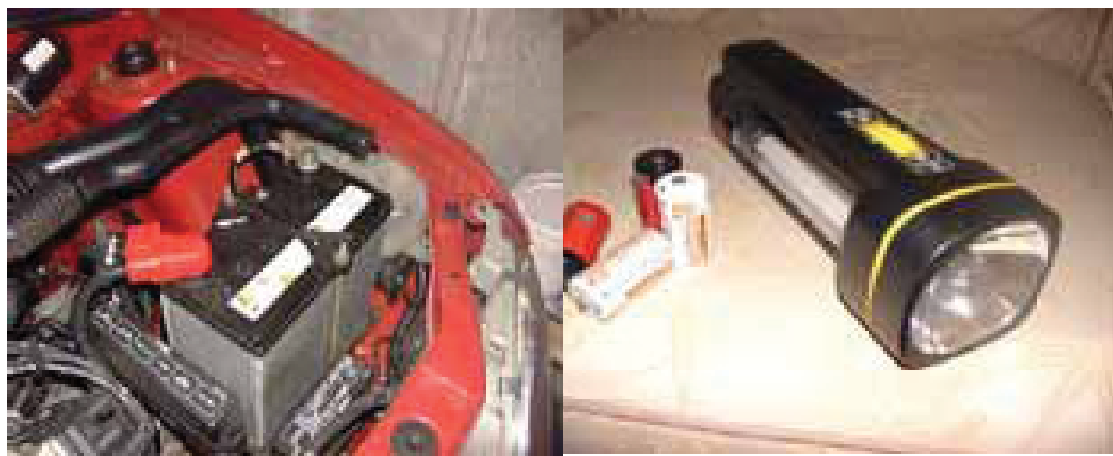

1.3 Electro-chemical Cells

An **electro-chemical cell** is a system consisting of **two half-cells** in which electrodes dip into an electrolyte. When they are connected electrically into a circuit, a chemical reaction occurs, which either uses or generates an electric current.

1.3.1 Half-cells

Generally half-cells are composed of a metal electrode immersed in the corresponding solution of metal ion as showed in the figure below.

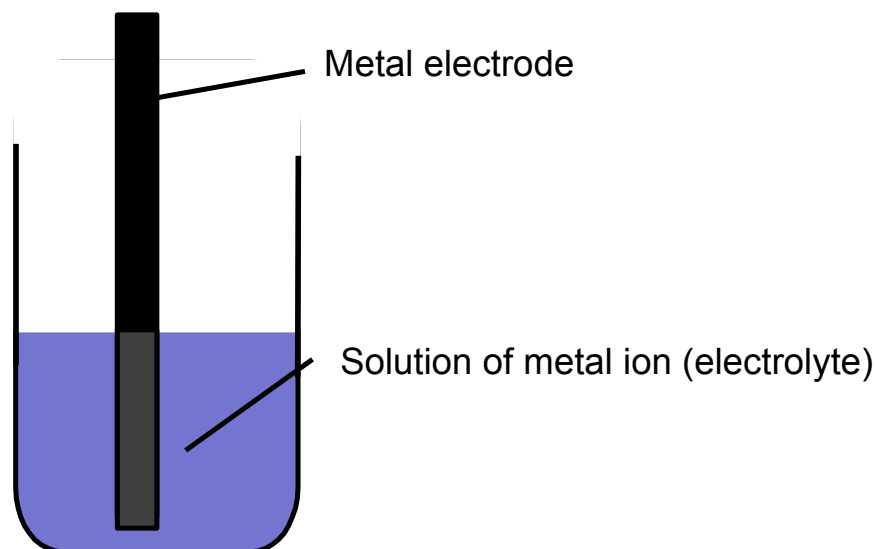

1.3.2 Voltaic Cells

A **voltaic** (also referred to as “galvanic”) cell is an electro-chemical cell in which a **spontaneous reaction** generates an electric **current**. This type of cell is able to produce an electric current because of a potential difference between the two electrodes.

An **electrolytic** cell is an electro-chemical cell in which an electric **current drives** an otherwise **non-spontaneous reaction**.

Each half-cell is a portion of the electro-chemical cell in which a half-reaction takes place. A simple half-cell can be made from a metal strip dipped into a solution of its metal ion.

For example, the zinc-zinc ion half cell consists of a zinc strip dipped into a solution of zinc sulphate.

Another simple half-cell consists of a copper strip dipped into a solution of a copper salt. In the cell, two half-cells are connected so that electrons flow from one metal electrode to the other through an external circuit. The figure below illustrates what is happening to the atoms in a zinc / copper voltaic cell.

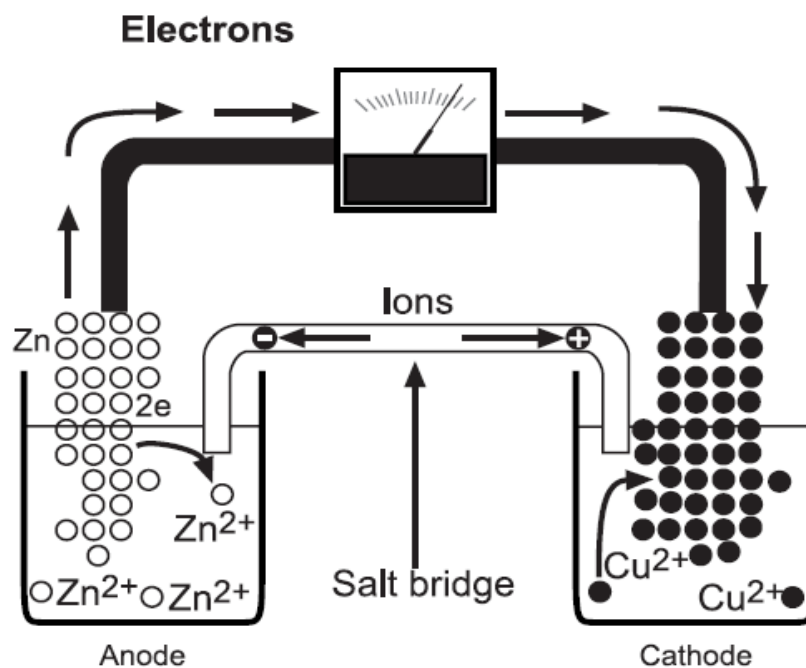

As long as there is an external circuit, electrons can flow through it from one electrode to the other. Zinc is a more reactive metal and has a greater tendency to lose electrons than copper. The zinc atoms in the zinc electrode lose electrons to form zinc ions.

The electrons flow through the external circuit to the copper electrode where copper ions gain the electrons to become copper metal.

The two half-cells must also be connected internally to allow ions to flow between them. Without this internal connection, too much positive charge builds up in the zinc half-cell (and too much negative charge in the copper half-cell) causing the reaction to stop. Thus, the two half-cells must be connected by a **salt bridge**.

1.3.3 Salt bridge

The salt bridge which connects the half cells is usually a tube of an electrolyte in a gel or a piece of filter paper soaked in the electrolyte. The salt bridge allows the flow of ions but prevents the mixing of the different solutions that would allow direct reaction of the cell reactants.

1.3.4 The complete electrical circuit

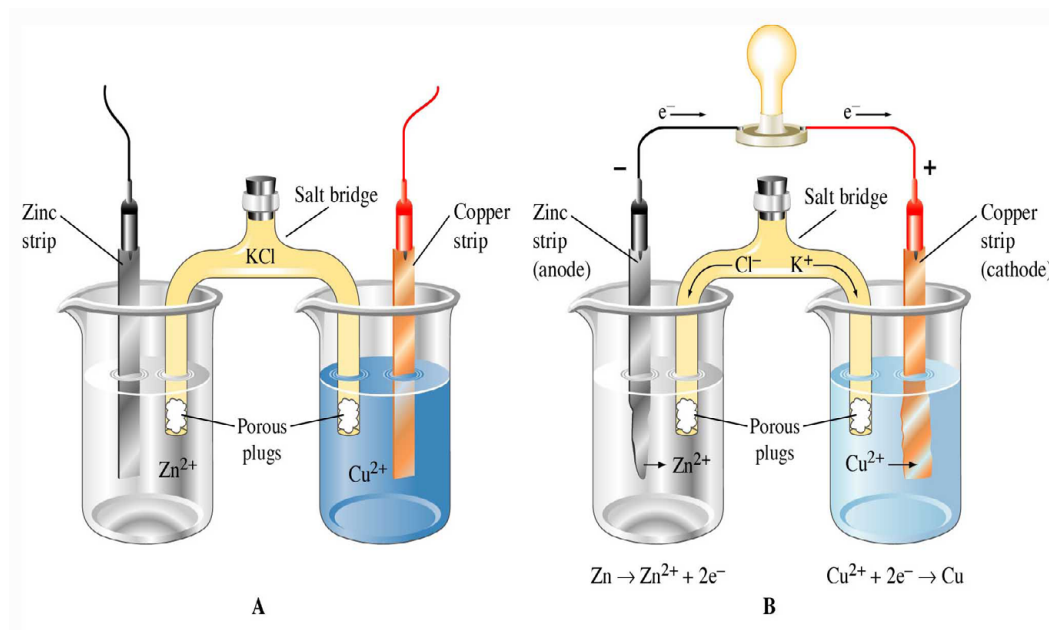

1.4 Effect on electrodes

It is important to note that the zinc electrode gradually gets smaller, as it reacts to form zinc ions in solution. Similarly, the copper electrode grows as copper ions in solution react to form more copper metal.

**YOUR WORK AT TOMTOM WILL
BE TOUCHED BY MILLIONS.
AROUND THE WORLD. EVERYDAY.**

Join us now on www.TomTom.jobs

follow us on **LinkedIn**



#ACHIEVEMORE

TOMTOM 

1.5 Half-cell redox reactions

The two half-cell reactions in the Zn/Cu cell are as follows:

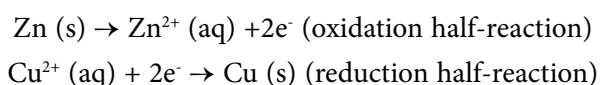

In the first reaction, electrons are lost by zinc atoms in an oxidation half-reaction. The electrode at which **oxidation** occurs is the **anode**.

The two half-cell reactions in the Zn/Cu cell are as follows:

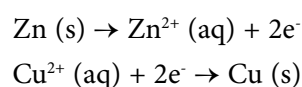

In the second reaction, electrons are gained by copper ions in a reduction half-reaction. The electrode at which **reduction** occurs is the **cathode**.

1.5.1 Overall cell reaction

The sum of the two half-reactions can be seen below:

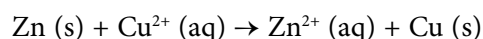

This is the net reaction that occurs in the electro-chemical cell. It is called the **cell reaction**. Note that electrons are given up at the anode and thus flow from it to the cathode where reduction occurs.

1.6 Anode and Cathode

ANODE: The **anode** is the electrode in a voltaic cell which has a **negative sign** because electrons flow from it.

CATHODE: The **cathode** in a voltaic cell has a **positive sign**.

1.7 Electro-chemical Cell Notation

It is easier to have a shorthand way of writing out particular electrochemical cells. A cell consisting of the zinc-zinc ion half-cell and the copper-copper ion half-cell, is written:

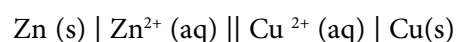

The **anode** (**oxidation** half-cell) is written on the **left**. The **cathode** (**reduction** half-cell) is written on the **right**.

A **single vertical bar** indicates a phase boundary, such as between a solid terminal and the electrolyte solution. The two electrolytes are connected by a **salt bridge**, denoted by **two vertical bars**. The cell terminals are at the extreme ends in the cell notation.

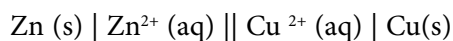

1.7.1 Hydrogen electrode

When the half-cell reaction involves a **gas**, an inert material such as platinum serves as a terminal and an electrode surface on which the reaction occurs. In a hydrogen electrode, hydrogen bubbles over a platinum plate immersed in an acidic solution.

The **anode** half-reaction is:

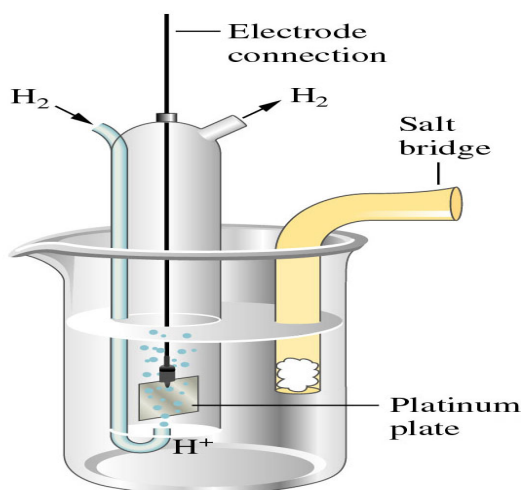
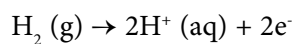

The notation for the hydrogen electrode, written as an anode, is shown below:

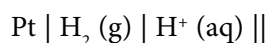

To write such an electrode as a cathode, the notation is simply reversed as shown below:



1.7.2 Same phase half-cells

Some half cells contain two related substances in solution rather than a metal in a solution of one of its salts.

E.g. a mixture of $\text{Br}_2(\text{l})$ and $\text{Br}^-(\text{aq})$

E.g. a mixture of $\text{Fe}^{2+}(\text{aq})$ and $\text{Fe}^{3+}(\text{aq})$

The cell diagram is written with a comma separating them rather than using the vertical bar separator |. However, an inert solid electrode is also needed.

E.g. $\text{Br}_2(\text{l}), \text{Br}^-(\text{aq}) | \text{Pt}$

1.7.3 Electro-chemical Cell

Sometimes the concentrations of the solutions and the pressure of gases are specified. In the cell notation, these are written in brackets.

For example:

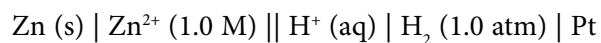

It should be noted that standard conditions are attained for concentrations of 1 mol.dm^{-3} and pressures of 1 atm.

Brain power

By 2020, wind could provide one-tenth of our planet's electricity needs. Already today, SKF's innovative know-how is crucial to running a large proportion of the world's wind turbines.

Up to 25 % of the generating costs relate to maintenance. These can be reduced dramatically thanks to our systems for on-line condition monitoring and automatic lubrication. We help make it more economical to create cleaner, cheaper energy out of thin air.

By sharing our experience, expertise, and creativity, industries can boost performance beyond expectations. Therefore we need the best employees who can meet this challenge!

The Power of Knowledge Engineering

Plug into The Power of Knowledge Engineering.
Visit us at www.skf.com/knowledge

SKF

1.8 Example

Give the overall cell reaction for the following electro- chemical cell

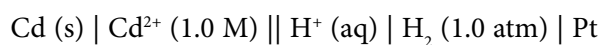

The half-cell reactions are:

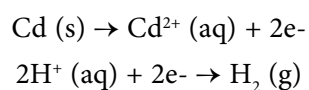

The overall reaction for the electro-chemical cell is therefore:

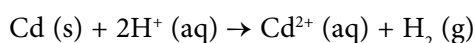

1.9 Exercise

- Write the half equations for the reactions in the electro-chemical cell below, stating which is at the anode and which at the cathode.

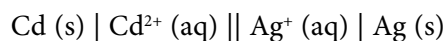

- (a) Write the cell diagram which represents the cell represented below.

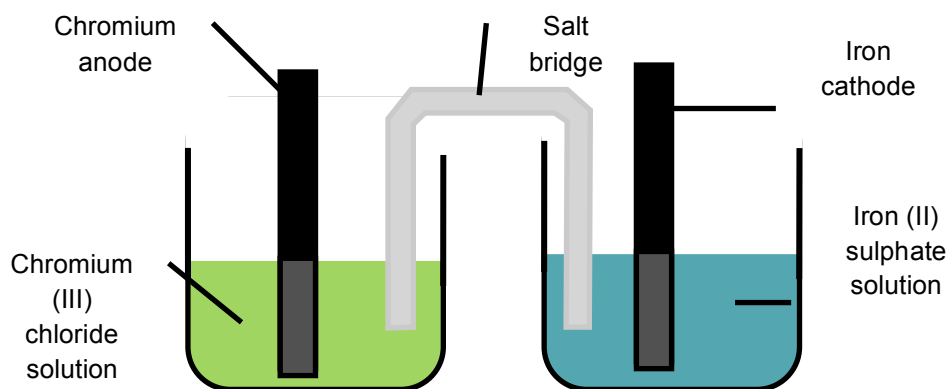

- (b) Write the overall cell reaction.

1.10 Potential Difference

Potential difference is the **difference** in electric potential (also referred to as electrical pressure) **between two points**. This difference in electrical potential can be measured by a voltmeter. The volt (symbol V) is the SI unit of potential difference.

The movement of electrons in electro-chemical cells can be compared to water flowing or being pumped from one point to another. Water moves from a point of high pressure to a point of lower pressure. Thus, a **pressure difference** is required. The **work** done in moving the water through a pipe depends on the **volume** of water and the **pressure difference**.

1.10.1 Electric Potential

Before an electro-chemical cell is connected, a redox reaction is ready to take place but cannot yet proceed. At the **anode**, the oxidation half-reaction is ready to produce surplus electrons, so there is a **high electric potential**. At the **cathode**, the reduction half-equation is ready to use up surplus electrons, so there is a **low electric potential**.

1.10.2 Redox couples

Note that each redox half reaction must always refer to a **pair of species**; the reduced form and the oxidised form.

The **reduction potential** of the redox couple is a measure of how easily the oxidised species **accepts an electron** to change to the reduced species.

The **oxidation potential** is a measure of how easily the reduced form **donates an electron** to change to the oxidised form. It is the negative of the reduction potential for the reverse reaction.

For example, the reaction $\text{Zn} \rightarrow \text{Zn}^{2+} + 2\text{e}^-$ happens easily. Whereas, the reaction $\text{Zn}^{2+} + 2\text{e}^- \rightarrow \text{Zn}$ does not happen easily.

Therefore, the following redox equilibrium lies well to the left as follows:

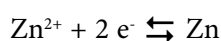

1.10.3 Potential Difference

The **difference in electric potential** between the two half-cells gives the **overall cell voltage**. If the two half-cells are connected by a wire and a voltmeter, the potential difference can be measured.

1.10.4 Electro-motive Force (emf)

Normally the potential difference (voltage) measured across the electrodes is less than the maximum possible voltage of the cell. This is because the actual flow of electrons reduces the electrical pressure. Thus, a cell voltage has its **maximum value** when **no current flows**.

1.10.4.1 Electro-motive Force: E_{cell}

The maximum potential difference between the electrodes of a voltaic cell is referred to as the **electro-motive force** (also called emf) of the cell, or E_{cell} . It can be measured by an electronic digital voltmeter, which draws negligible current.

A digital voltmeter

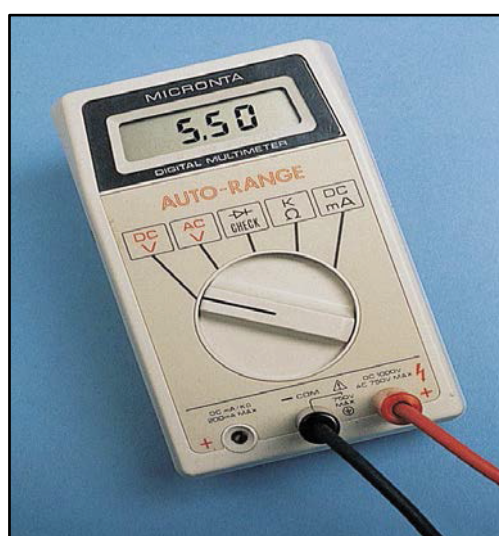

1.10.4.2 Potential Difference

Potential difference is a measure of the capacity of the cell to do work by moving electric charge through that potential difference. The amount of work that can be done is **directly related to the enthalpy ΔH** for the redox reaction (strictly ΔG , the free energy change which also incorporates entropy S).

1.10.5 Electrical work

The amount of **work done** in moving an electrical charge through a conductor from a point of high electrical potential (or high electrical pressure) to one of lower electrical potential is dependent on:

- The **amount of charge**, and
- The **potential difference**.

1.10.6 Potential difference

By definition, Electrical Work [J] = Charge [C] \times Potential Difference [V]

Therefore, one volt is equivalent to one joule of energy per coulomb of charge. In other words, $1\text{V} = 1\text{J} / 1\text{C}$.

1.10.7 Faraday constant

We know that the charge of one electron is 1.60×10^{-19} C. Thus, the charge carried by one mole of electrons will be $6.02 \times 10^{23} \times 1.60 \times 10^{-19} = 96,500$ coulombs.

We note that **96,500 C** is also called **1 Faraday** (named after the English scientist Michael Faraday). The Faraday constant (F) is the amount of charge in one mole of electrons.

In moving one mol of electrons through a circuit, the value of the work done by an electro-chemical cell is the product of the Faraday constant (referred to as F) by the potential difference between the electrodes as shown below:

$$\text{Work [J]} = - F [\text{C}] \times \text{Potential Difference [V]}$$



> Apply now

REDEFINE YOUR FUTURE
**AXA GLOBAL GRADUATE
PROGRAM 2015**

redefining / standards 

agence.cdg. © Photonistop

1.10.8 Electromotive Force

We can now write an expression for the **maximum work** attainable by an electro-chemical cell. Let “n” be the number of electrons (in mol) transferred in the overall electrochemical cell reaction. The maximum work (**W_{max}**) for molar amounts of reactants is given by the following formula:

$$W_{\max} = - n \times F \times E_{\text{cell}}$$

1.11 Example

The following cell has an emf of 0.650 V.



Calculate the maximum electrical work of this cell when 0.50 g H₂ is consumed.

First write the half-reactions:

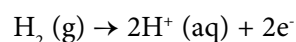
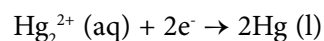

Balance the number of electrons in the two half-equations to give the following overall reaction:

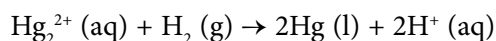

The number of moles of electrons transferred is equal to $n = 2$. So the maximum work for molar amounts in the reaction is written as

$$W_{\max} = - n \times F \times E_{\text{cell}}$$

$$W_{\max} = - 2 \times 96,500 \times 0.650$$

$$W_{\max} = - 1.25 \times 10^5 \text{ J}$$

For 0.50 g H₂, the maximum work is proportional to the number of moles:

$$(0.50 / 2.02) \times - 1.25 \times 10^5 = - 3.09 \times 10^4 \text{ J}$$

1.12 Standard Electrode Potentials

A cell electromotive force (or “emf”) is a **measure of the driving force** of the electro-chemical cell reaction. The reaction at the anode has a **definite oxidation potential, while the reaction at the cathode has a definite** reduction potential.

Thus, the overall cell emf is a combination of these two potentials and therefore we have $E_{\text{cell}} = \text{oxidation potential} + \text{reduction potential}$.

A voltage cannot be measured just for a half-cell but only for a **complete cell**. Therefore, to describe the reduction potential for a particular redox couple, the emf is measured for a cell where the other half-cell is a **standard reference electrode**.

The reference electrode is usually assigned a **potential of zero** and the potential of the other electrode is obtained relative to this by measuring the cell emf. Typically, the reference chosen is the **standard hydrogen electrode**.

Note that measurements are made under standard conditions

- Pressure of any gas: 1 atmosphere
- Concentration of solutions: 1 mol.dm^{-1}
- Temperature: 298 K (25°C)

For example, for a cell composed of a zinc electrode connected to a hydrogen electrode, the measured emf is 0.76 V. Zinc is found to act as the anode, so the Zn/Zn²⁺ oxidation potential is 0.76 V.

Standard electrode potentials are usually all listed as reduction potentials i.e. by **reversing the oxidation potential**. Thus, the Zn/Zn²⁺ reduction potential is listed as $E_{\text{Zn}} = -0.76\text{V}$.

1.12.1 Standard Reduction Potentials

The electrode potential is an intensive property whose value is independent of the amount of species in the reaction. Thus, the electrode potential for the following half-reaction is the same for this half-reaction $\text{Cu}^{2+}(\text{aq}) + 2\text{e}^{-} \rightarrow \text{Cu}(\text{s})$ is the same for this half-reaction $2\text{Cu}^{2+}(\text{aq}) + 4\text{e}^{-} \rightarrow 2\text{Cu}(\text{s})$.

A list of common standard reduction potentials is given in the table below.

Reaction	E° (V)
$\text{Li}^+ (\text{aq}) + \text{e}^- \rightarrow \text{Li} (\text{s})$	-3.04
$\text{Al}^{3+} (\text{aq}) + 3\text{e}^- \rightarrow \text{Al} (\text{s})$	-1.66
$\text{Zn}^{2+} (\text{aq}) + 2\text{e}^- \rightarrow \text{Zn} (\text{s})$	-0.76
$\text{Cr}^{3+} (\text{aq}) + 3\text{e}^- \rightarrow \text{Cr} (\text{s})$	-0.74
$\text{Fe}^{2+} (\text{aq}) + 2\text{e}^- \rightarrow \text{Fe} (\text{s})$	-0.41
$\text{Co}^{2+} (\text{aq}) + 2\text{e}^- \rightarrow \text{Co} (\text{s})$	-0.28
$\text{Ni}^{2+} (\text{aq}) + 2\text{e}^- \rightarrow \text{Ni} (\text{s})$	-0.25
$\text{Pb}^{2+} (\text{aq}) + 2\text{e}^- \rightarrow \text{Pb} (\text{s})$	-0.13
$2\text{H}^+ (\text{aq}) + 2\text{e}^- \rightarrow \text{H}_2 (\text{g})$	0.00
$\text{Cu}^{2+} (\text{aq}) + 2\text{e}^- \rightarrow \text{Cu} (\text{s})$	+0.34
$\text{I}_2 (\text{s}) + 2\text{e}^- \rightarrow 2\text{I}^- (\text{aq})$	+0.54
$\text{Br}_2 (\text{l}) + 2\text{e}^- \rightarrow 2\text{Br}^- (\text{aq})$	+1.07
$\text{F}_2 (\text{g}) + 2\text{e}^- \rightarrow 2\text{F}^- (\text{aq})$	+2.87

1.12.2 Calculating E_{cell}

Consider the zinc-copper cell described earlier. How can the emf of such a cell be calculated from the standard potentials, rather than by experiment? The two half-reactions are

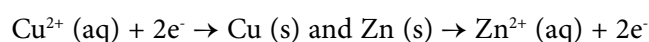

LIGS University

based in Hawaii, USA

is currently enrolling in the
Interactive Online **BBA, MBA, MSc,**
DBA and PhD programs:

- ▶ enroll **by October 31st, 2014** and
- ▶ **save up to 11%** on the tuition!
- ▶ pay in 10 installments / 2 years
- ▶ Interactive **Online** education
- ▶ visit www.ligsuniversity.com to find out more!

Note: LIGS University is not accredited by any nationally recognized accrediting agency listed by the US Secretary of Education. More info [here](#).





The copper half-reaction is a reduction. Look up for E_{Cu} , the standard reduction potential in the table above for the following half-reaction.

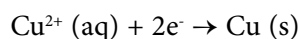

We find that $E_{\text{Cu}} = + 0.34\text{V}$.

The zinc half-reaction is an oxidation. Please note that tables usually list reduction potentials.

If E_{Zn} is the reduction potential of zinc, then $E_{\text{Zn}} = - 0.76\text{V}$ as per the values found in the table above. Similarly, $(- E_{\text{Zn}})$ is the oxidation potential of zinc. Therefore, $(- E_{\text{Zn}}) = +0.76 \text{ V}$ for the following half-reaction:

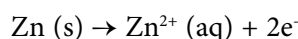

The cell emf is the sum of the reduction potential for the copper half-cell and the oxidation potential for the zinc half-cell.

We can say that $E_{\text{cell}} = E_{\text{Cu}} + (- E_{\text{Zn}})$, which is equal to $E_{\text{cell}} = E_{\text{Cu}} - E_{\text{Zn}}$

Therefore, $E_{\text{cell}} = 0.34 + 0.76 = 1.1 \text{ V}$

Note that this is equal to the emf that would be measured from a cell combining these two half-cells.

1.12.3 Quick method

Note that the emf of the cell equals the standard electrode potential of the cathode minus the standard electrode potential of the anode.

This is usually a quicker way to calculate the emf.

1.13 Example

Calculate the emf for the following voltaic cell:

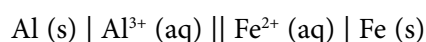

Simply use the following equation:

$$E^{\circ}_{\text{cell}} = E^{\circ}_{\text{cathode}} - E^{\circ}_{\text{anode}}$$

$$E^{\circ}_{\text{cell}} = - 0.41 - (- 1.66)$$

$$E^{\circ}_{\text{cell}} = 1.25 \text{ V}$$

1.13.1 Quick Method

Remember to use the following expression: $E_{\text{cell}}^{\circ} = E_{\text{cathode}}^{\circ} - E_{\text{anode}}^{\circ}$ and use the **signs and values** as given in **the standard reduction potential** tables. The correct allocation to cathode or anode will keep the signs correct.

1.14 Exercise

1.14.1 Calculate the emf of this cell: $\text{Mg (s)} \mid \text{Mg}^{2+} \text{ (aq)} \parallel \text{Ag}^{+} \text{ (aq)} \mid \text{Ag (s)}$

Write an equation for the overall cell reaction.

1.14.2 What is E_{cell} for $\text{Cr (s)} \mid \text{Cr}^{3+} \text{ (aq)} \parallel \text{Ag}^{+} \text{ (aq)} \mid \text{Ag (s)}$

Look up for the values of the standard electrode potentials in the table above.

TURN TO THE EXPERTS FOR SUBSCRIPTION CONSULTANCY

Subscribe is one of the leading companies in Europe when it comes to innovation and business development within subscription businesses.

We innovate new subscription business models or improve existing ones. We do business reviews of existing subscription businesses and we develop acquisition and retention strategies.

Learn more at [linkedin.com/company/subscribe](https://www.linkedin.com/company/subscribe) or contact
Managing Director Morten Suhr Hansen at mha@subscribe.dk

SUBSCR✓**BE** - to the future

2 Electrochemistry (2)

Learning Objectives

- Predict if an electro-chemical reaction will take place.
- Recognise which reaction is the oxidation and which is the reduction.
- Introduction to the process of rusting
- Identify commercially-available electro-chemical cells.
- Introduction to electrolytic cells
- Introduction to electrolysis of molten salts
- Calculate the standard potential value of a redox equation

2.1 Predicting Reactions

Standard reduction potential E° values can be used to predict whether a redox reaction will happen spontaneously or not.

Find the standard reduction potential of the two half reactions:

- The more positive standard reduction potential will occur as a reduction.
- The more negative one will occur as an oxidation.

A question one can ask is can silver reduce Cu^{2+} ?

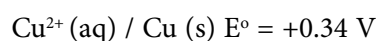
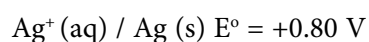

By comparing the two E° values it is possible to understand how the reaction is likely to proceed. + 0.80 is greater than + 0.34, so $\text{Ag}^+ (\text{aq}) \rightarrow \text{Ag} (\text{s})$ must be the reduction reaction. Then the reaction between Ag and Cu^{2+} (the opposite of this) will not take place spontaneously.

Imagine how the possible reaction could be part of an electrochemical cell. As voltaic cells always have a positive cell emf, calculating E_{cell} can tell whether a possible redox reaction will proceed spontaneously or not.

Note that although calculating the emf of a possible reaction will tell whether a reaction will happen, it does not give information on how quickly such a reaction would happen.

For example, can silver reduce Cu^{2+} ? This reaction would involve a cell where silver was oxidised at the anode and copper ions were reduced at the cathode as follows:

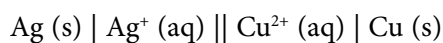

Remember that:

$$E_{\text{cell}} = E^{\circ}_{\text{cathode}} - E^{\circ}_{\text{anode}}$$

So $E_{\text{cell}} = +0.34 - (+0.80) = -0.46$ V. As the calculated value is negative, the reaction will not take place spontaneously.

Similarly, would there be a reaction between Na and Mg^{2+} ?

$$E_{\text{cell}} = (-2.37) - (-2.71) = +0.34$$
 V.

E_{cell} is positive therefore, the reaction would proceed.

These ideas are expressed more simply by the concept of an activity series of metals. The most reactive metals are those which are most **easily oxidised**. As the **more positive** E° values indicate species which are the **strongest reducing agents**, the **most reactive metals** are those which have the **most negative** metal ion/metal E° value.

2.2 Strengths of Oxidising and Reducing Agents

Standard electrode potentials are useful in determining the strengths of any oxidising and reducing agents under standard-state conditions.

- A reduction half-reaction has the general form



The oxidised species acts as an oxidising agent. Therefore the strongest oxidising agents in a table of standard electrode potentials are the oxidised species corresponding to the half-reactions with the **largest (most positive)** E° values. These reactions will have a strong tendency to go from left to right.

For example F_2 (g):

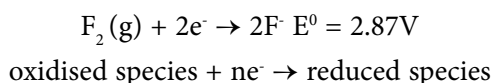

- An oxidation half-reaction has the general form



The reduced species acts as a reducing agent. As standard electrode potential tables are always written with respect to **reduction potentials**, the strongest reducing agents in a table of standard electrode potentials are the reduced species (on the right) corresponding to the half- reactions with the smallest (most negative) E_0 values.

For example $\text{Li}^+(\text{aq})$:

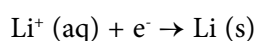

2.2.1 Exercise

Use the standard electrode potentials to answer the following questions:

- Which is the stronger oxidising agent, Cl_2 or I_2 ?
- Which is the stronger reducing agent, Fe^{2+} or Fe ?



"I studied English for 16 years but...
...I finally learned to speak it in just six lessons"
Jane, Chinese architect

ENGLISH OUT THERE

Click to hear me talking before and after my unique course download

2.3 Rusting

Look at the following two half equations:

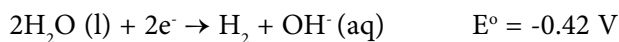

Will the reaction between Fe and H₂O proceed? The reaction will proceed spontaneously, but with only a small emf. However, if oxygen is also present, another reaction can also take place:

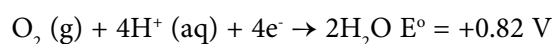

This reaction has a sufficiently positive emf to readily oxidise the Fe to Fe²⁺, and then consequently to Fe³⁺. The final product is a brown/orange compound of formula Fe₂O₃·x H₂O, which is commonly referred to as rust.

Rusting is the cause of **extensive corrosion of iron** pipelines, tanks, buildings etc, which is difficult and expensive to repair. Thus, iron and steel need to be **protected** by painting, greasing or galvanising, so that the oxygen is not allowed in contact with the iron. Alternatively, a piece of a **more reactive metal**, such as magnesium is attached at a convenient place. This will form a voltaic cell, in which the magnesium forms the anode, and the iron acts as the cathode. Thus the magnesium, rather than the iron, will be oxidised – and can simply be replaced when used up. This use of an active metal is called cathodic (or sacrificial) protection.

2.4 Some Commercial Electrochemical Cells

2.4.1 Leclanché dry cell

The Leclanché dry cell, or zinc-carbon dry cell, is a voltaic cell with a zinc can as the anode and a graphite rod in the centre surrounded by a paste of manganese dioxide, ammonium and zinc chlorides, and carbon black, as the cathode.

The electrode reactions are as follows

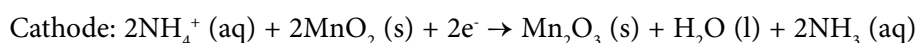

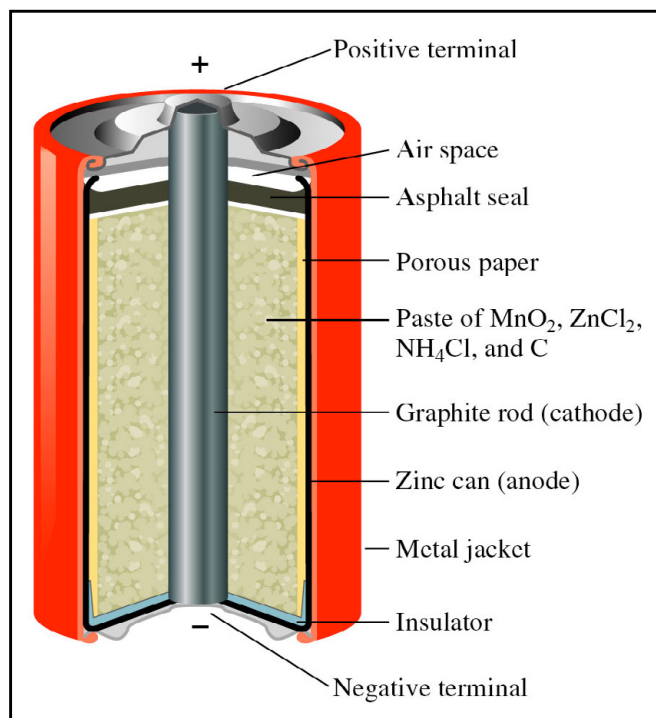

2.4.2 Storage cell

The lead storage cell (a rechargeable cell) consists of electrodes of lead alloy grids; one electrode is packed with a spongy lead to form the anode, and the other electrode is packed with lead dioxide to form the cathode.

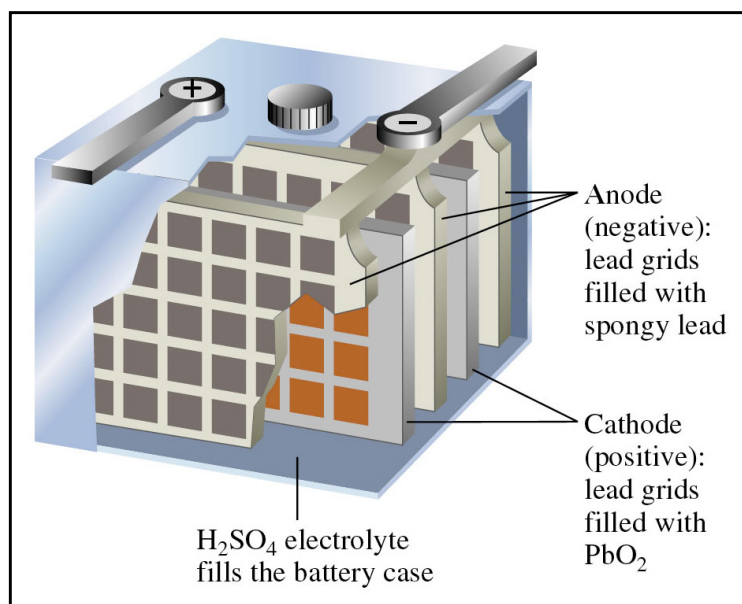

2.4.3 Fuel cell

A proton-conducting polymer membrane (the electrolyte) separates both the anode and cathode sides as shown below.

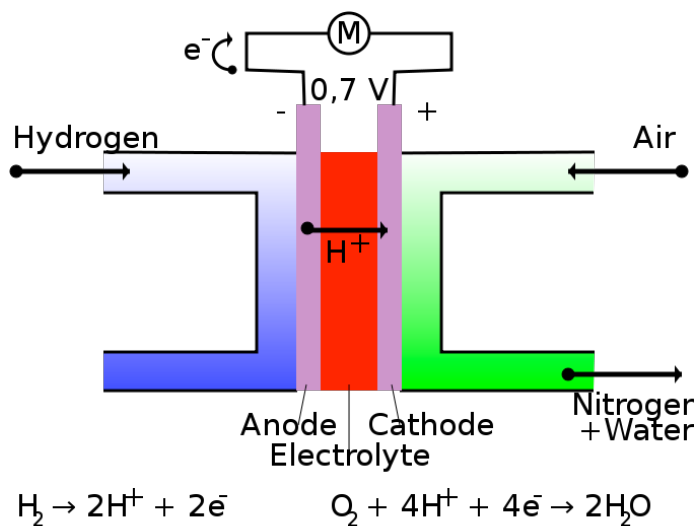

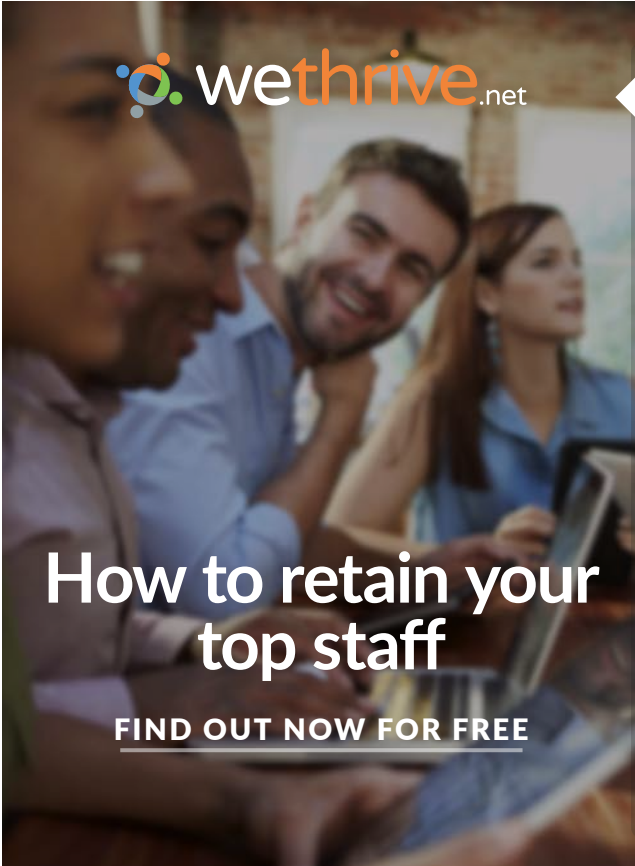

wethrive.net

How to retain your top staff

FIND OUT NOW FOR FREE

DO YOU WANT TO KNOW:

- 🧠
What your staff really want?
- ✅
The top issues troubling them?
- 🕒
How to make staff assessments work for you & them, painlessly?

Get your free trial

Because happy staff get more done



A fuel cell is essentially a battery, but differs by operating with a continuous supply of energetic reactants, or fuel. For a hydrogen-oxygen fuel cell, the electrode reactions are as follows:

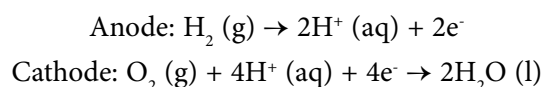

2.5 Electrolytic Cell

An electrolytic cell is an electro-chemical cell in which an electric current drives an otherwise **non-spontaneous reaction**. Note that the electrolytic cell requires an external power source as shown in the Figure below.

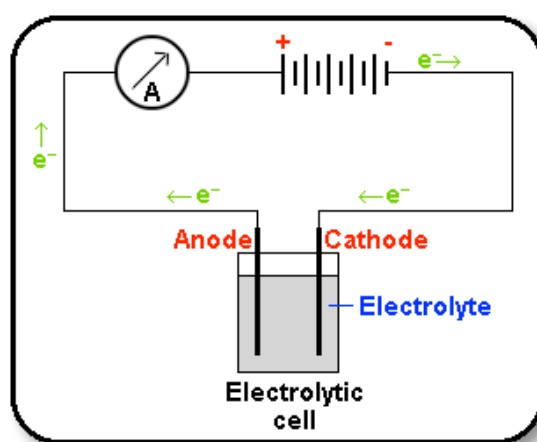

When a direct electric current is passed through an electrolyte (such as a molten salt or an aqueous solution of a salt, acid or base), chemical reactions take place at the contacts between the circuit and the solution. This process is called electro-pyrolysis.

When copper iodide is electrolysed, the following reactions take place:

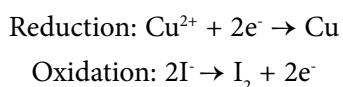

Note that these reactions are the opposite of those which would happen spontaneously in a voltaic cell.

The electrode which is attached to the **negative pole** of the battery, and which **supplies electrons** to the electrolyte, is called the cathode. **Reduction** takes place at the **cathode**. The electrode which is attached to the **positive pole** of the battery, and which **accepts electrons** from the electrolyte, is called the **anode**. **Oxidation** takes place at the **anode**.

Note that in an electrolytic cell, the charges on the anode and cathode are **opposite** to those in a voltaic cell. In an electrolytic cell, the cathode has negative charge.

In an electrolytic cell, the anode has positive charge. In a voltaic cell, the cathode has positive charge. In a voltaic cell, the anode has negative charge.

Cations (ions of positive charge) will be attracted to the negative cathode. Anions (ions of negative charge) will be attracted to the positive anode. For example, during the electrolysis of molten NaCl:

- Na^+ ions are attracted to the cathode, where they will be reduced to Na.
- Cl^- ions will be attracted to the anode, where they will be oxidised to Cl_2

2.6 Electrolysis of Molten Salts

A Downs cell is a commercial electro-chemical cell used to obtain sodium metal by electrolysis of molten NaCl. A number of other reactive metals are obtained by the electrolysis of a molten salt. Many important substances, such as aluminium metal and chlorine gas are produced commercially by electrolysis.

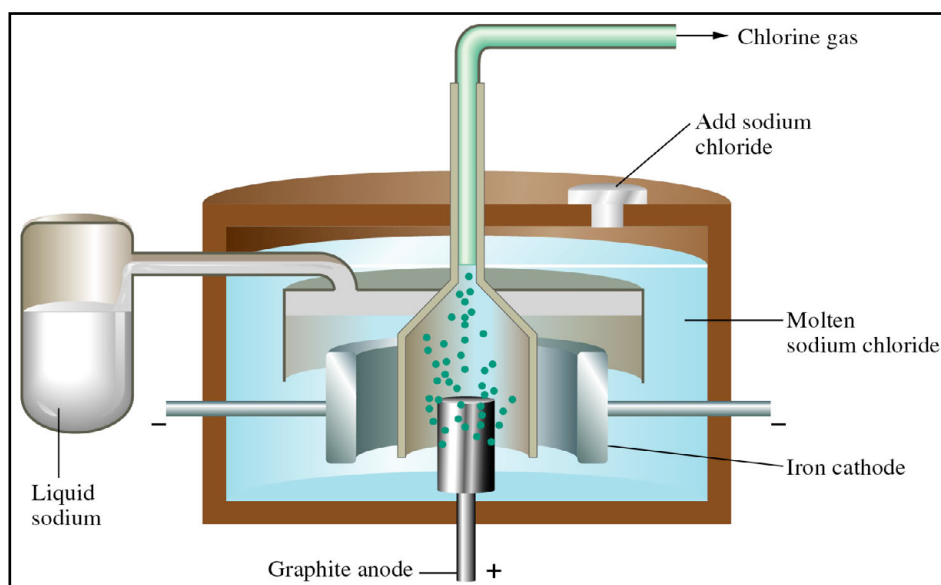

2.6.1 Aqueous electrolysis

Electrolysis of molten ionic compounds will yield the elements from the salt, however electrolysis of aqueous solutions of salts often result in the oxidation and/or reduction of the water instead, yielding H_2 and O_2 . For example, the electrolysis of concentrated NaCl solution yields Cl_2 at the anode, but H_2 rather than Na at the cathode.

2.6.2 Stoichiometry of Electrolysis

How can we work out the mass of substances released at either electrode in an electrochemical cell? Michael Faraday found that the mass of substances released at the electrodes is directly related to the total charge that has passed through the electrical circuit of the cell. To determine this we must **know the current** and **the length of time** it has been flowing.

Electric current is measured in amperes. An ampere (A) is the base SI unit of current equivalent to 1 coulomb/second. The quantity of electric charge passing through a circuit in a given amount of time is given by the following equation:

$$\text{Electric charge (C)} = \text{electric current (C.s}^{-1}\text{)} \times \text{time (s)}$$

$$\text{Charge (C)} = \text{Current (A)} \times \text{time (s)}$$

In terms of symbols:

$$Q = I \times t$$



gaieteye
Challenge the way we run

EXPERIENCE THE POWER OF
FULL ENGAGEMENT...

RUN FASTER.
RUN LONGER..
RUN EASIER...

READ MORE & PRE-ORDER TODAY
WWW.GAITEYE.COM

By definition, a current of one ampere flowing for one second is equal to one coulomb of charge. So measuring the current in a circuit and the time it flows for can give the amount of charge used.

The charge on an electron is 1.6×10^{-19} coulombs. The charge carried by one mole of electrons will be: $6.02 \times 10^{23} \times 1.6 \times 10^{-19} = 96,500$ coulombs. We note that 96,500 C is also called 1 Faraday.

During electrolysis, the production of one mole of an element from its ion requires $n \times 96,500$ C (where n is the charge on the ion).

For example, $\text{Na}^+ + e^- \rightarrow \text{Na}$ will use one electron per ion. So this reaction will use a total of 96,500 C of charge. Similarly, $\text{Cu}^{2+} + 2e^- \rightarrow \text{Cu}$ will use two electrons per ion. So this reaction will use a total of $2 \times 96,500 = 193,000$ C of charge.

2.6.3 Faraday Calculations

In the electrolysis of copper chloride, what mass of copper would be produced by a current of 1000 A running for 1 hour? First it is necessary to calculate the total charge passed using:

$$Q = I \times t$$
$$Q = 1000 \text{ (A)} \times 60 \times 60 \text{ (s)} = 3,600,000 \text{ C}$$

The reaction which involves copper is $\text{Cu}^{2+} \text{ (aq)} + 2e^- \rightarrow \text{Cu} \text{ (s)}$

So a charge equal to $2 \times 96,500$ C would be needed to produce one mole of copper. The number of moles of copper is equal to the total charge (in C) divided by the charge needed to produce one mol of copper as follows:

$$\text{Moles Cu} = 3,600,000 / (2 \times 96,500)$$
$$\text{Moles Cu} = 18.65 \text{ mol}$$

The mass of copper is equal to the moles of copper times the RAM of copper as follows:

$$\text{Mass Cu} = \text{Moles Cu} \times \text{RAM Cu}$$
$$\text{Mass Cu} = 18.65 \times 63.5 = 1,184 \text{ g}$$

2.7 Calculation Examples

Typically, large currents are used in the extraction of aluminium from the ore Bauxite (aluminium oxide). Calculate the average current flowing if one electrolysis cell produces 1 tonne (1000kg) of aluminium a day.

$$\text{Moles Al} = \text{mass Al} / \text{RAM Al}$$

$$\text{Moles Al} = 1,000,000 / 27$$

$$\text{Moles Al} = 37,037 \text{ moles}$$

According to Faraday, $3 \times 96,500$ C of charge are used to produce one mole of aluminium as follows

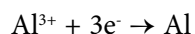

The charge needed for 1 mole of aluminium is equal to:

$$\text{Charge} = 3 \times 96,500 = 289,500 \text{ C}$$

The charge needed for 1 tonne

$$\text{Total charge} = \text{moles} \times \text{charge}$$

$$\text{Total charge} = 37,037 \times 289,500$$

$$\text{Total charge} = 1.0722 \times 10^{10}$$

Therefore the corresponding time needed is equal to:

$$\text{Time} = 24 \times 60 \times 60 = 86,400 \text{ s}$$

Finally, by using $Q = I \times t$, it is possible to determine the current I as follows:

$$I = Q / t = 124,100 \text{ A}$$

2.8 Example

When an aqueous solution of potassium iodide is electrolysed using platinum electrodes, the half-reactions are:

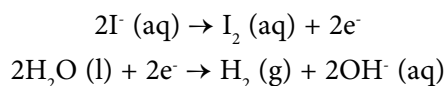

How many grams of iodine are produced when a current of 8.52 mA flows through the cell for 10 min?

When the current flows for 6.00×10^2 s (i.e. 10.0 min), the amount of charge is equal to:

$$(8.52 \times 10^{-3} \text{ A}) \times (6.00 \times 10^2 \text{ s}) = 5.11 \text{ C}$$

Note that two moles of electrons are equivalent to one mole of I_2 . This gives us the following calculation:

$$\begin{aligned} \text{Mass} &= 5.11 \text{ C} \times (1 \text{ mol } e^- / 96,500) \times (1 \text{ mol } \text{I}_2 / 2 \text{ mol } e^-) \times (254 \text{g } \text{I}_2 / 1 \text{ mol } \text{I}_2) \\ \text{Mass } \text{I}_2 &= 6.73 \times 10^{-3} \text{g} \end{aligned}$$

Summary

Electro-chemical cells consist of two half-cells between which electrical contact is made by an electrolyte, often in the form of a salt-bridge.

Each half-cell generates a potential difference that causes electrons to move in the external circuit.

The overall cell voltage (e.m.f.) is the sum of the electrode potentials of each electrode.

The size of this voltage depends on the cell reaction, temperature and concentrations.

An electro-chemical cell can be described by a standard cell notation such as

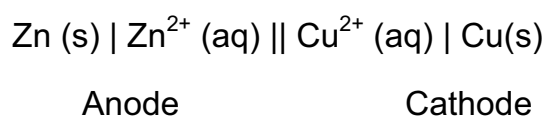

Individual electrode potentials cannot be measured but values are obtained by comparison with the standard hydrogen electrode.

Standard Reduction Potentials (E^0 values) can be used to:

- calculate a cell e.m.f. under standard conditions.
- estimate relative strengths of oxidising agents and reducing agents.

Fuel cells operate like electrochemical cells, the only difference being that the fuel for the reaction is continually provided from an external source.

3 Chemical Equilibrium

Learning Objectives

- Apply stoichiometry to an equilibrium mixture
- Write equilibrium-constant expressions
- Obtain the equilibrium constant from reaction composition
- Obtain one equilibrium concentration given the others
- Solve equilibrium problems

This e-book
is made with
SetaPDF



PDF components for **PHP** developers

www.setasign.com



3.1 Reversible Reactions

If steam is passed over hot iron, hydrogen and tri-iron tetroxide are produced as shown below

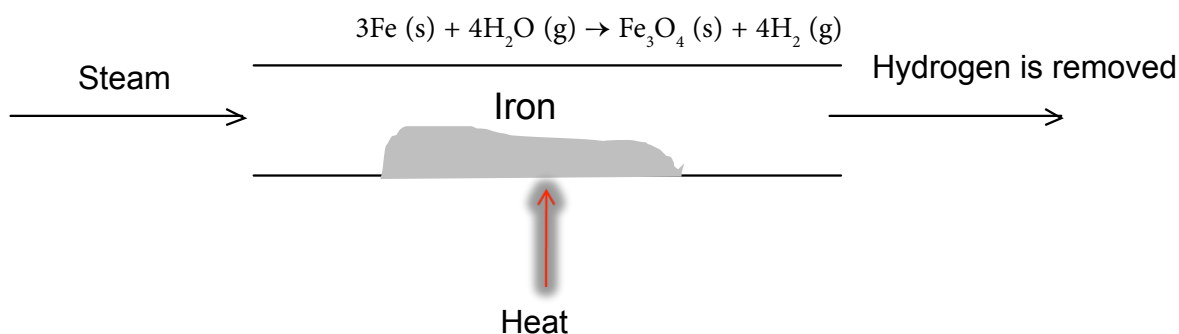

This reaction can be reversed by passing hydrogen over tri-iron tetroxide to produce iron and steam as shown below

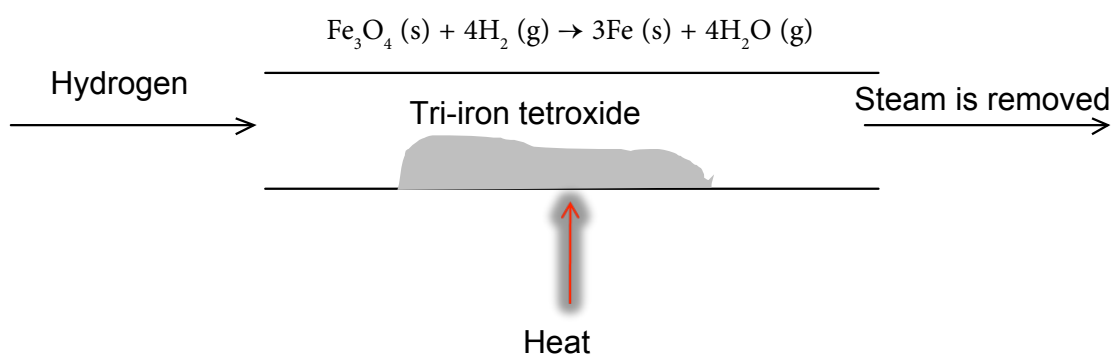

Under the conditions shown each reaction is one way with the products being removed from the reaction mixture.

Under these conditions **no reverse reaction can happen**. To allow the reverse reaction to happen products must not be lost from the system i.e. the reaction must be carried out in a **closed system**.

3.2 Reactions in a closed system

If the iron were to be heated in a closed system (where no reactants may be added and no products lost), then at some point the composition of the reaction mixture would remain constant, and **all four species** would be present as shown in the following equilibrium.

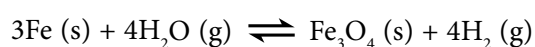

3.2.1 Chemical equilibrium

When substances react in a closed system, they eventually form a mixture of constant composition of products and unreacted reactants, in a dynamic equilibrium.

A **dynamic equilibrium** consists of a forward reaction, in which substances react to give products, and a reverse reaction, in which products react to give the original reactants. Instead of the usual arrow to represent a dynamic equilibrium, we write the symbol associated to equilibrium reactions as:



3.2.2 Approaching equilibrium

The stable equilibrium position can be obtained by starting with:

- The reactants only;
- The products only;
- Or from a mixture of all of these.

Once the equilibrium has been established, the composition of the equilibrium mixture will be exactly the same, no matter which direction the equilibrium was approached.



Discover the truth at www.deloitte.ca/careers

Deloitte.

© Deloitte & Touche LLP and affiliated entities.



Consider the following reaction:

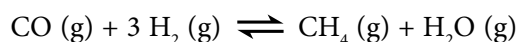

When CO and H₂ are mixed, the concentrations of CO and H₂ will rapidly decrease. Similarly, the concentration of CH₄ and H₂O will rise.

As both the concentrations of CH₄ and H₂O increase the reverse reaction reforming CO and H₂ will start to occur. Eventually the rates of the forward and reverse reactions will become equal meaning that the reaction has reached an equilibrium as shown in the figures below.

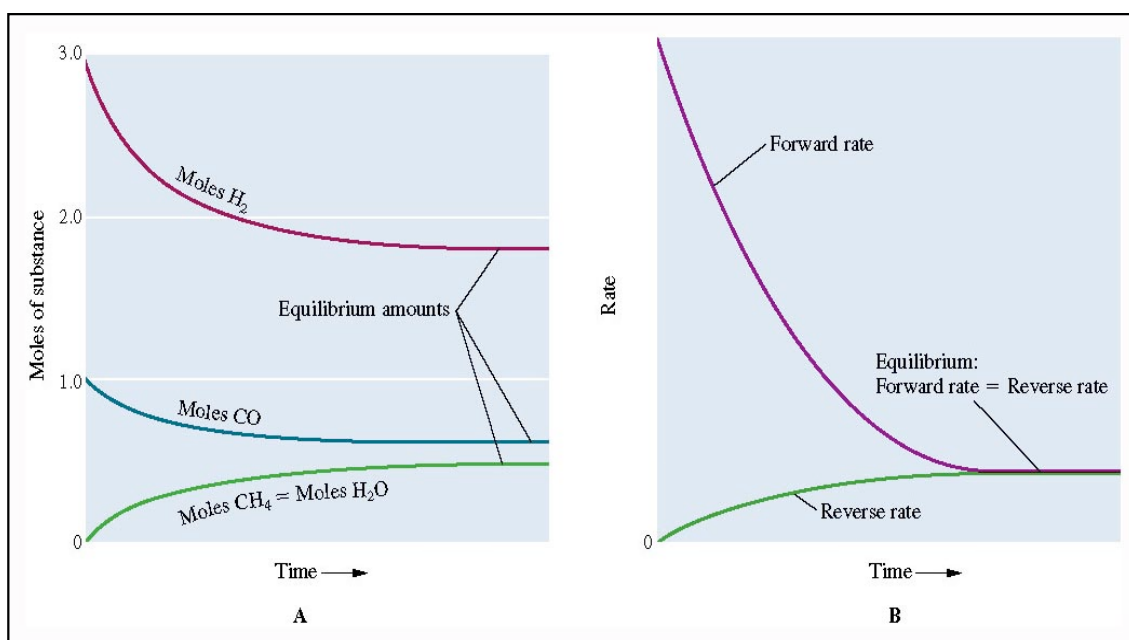

3.2.3 Applying stoichiometry to an equilibrium mixture

If the **starting concentrations** of all the reactants are known, and the **concentration of one substance at equilibrium**, then the equilibrium concentrations of **all the substances** can be calculated.

3.3 Haber's process

The Haber's process for producing ammonia from N₂ and H₂ is an important industrial example of a reaction that does not go to completion.

It establishes an **equilibrium state** where all the **three species** are present.

3.3.1 Example

Suppose we place 1.00 mol of N_2 and 3.00 mol of H_2 in a reaction vessel at a temperature of 450 °C and pressure of 10.0 atm. The Haber's reaction is:

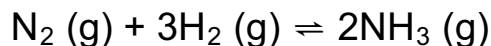

What is the composition of the equilibrium mixture if it contains 0.08 mol of NH_3 ?

3.3.2 Solution

Using the information given, a table can be created in terms of "x", **the change in the number of moles of one reactant** as shown in the table below:

Amount (mol)	N_2	H_2	NH_3
Starting	1.00	3.00	0
Change	- x	- 3x	+ 2x
Equilibrium	1.00 - x	3.00 - 3x	2x = 0.08 mol

The equilibrium amount of NH_3 is equal to 0.08 mol. Therefore, $2x = 0.08$ mol and then $x = 0.04$ mol of NH_3 .

- Equilibrium amount of $N_2 = 1.00 - 0.04 = 0.96$ mol of N_2
- Equilibrium amount of $H_2 = 3.00 - (3 \times 0.04) = 2.88$ mol of H_2
- Equilibrium amount of $NH_3 = 2 \times 0.04 = 0.08$ mol of NH_3

Note that there is far more H_2 and N_2 present at equilibrium than NH_3 . This will **not change**, no matter how long the reaction is left.

Note that being at equilibrium **does not mean that the amount of reactants equals the amount of product**.

3.4 The equilibrium constant

Every reversible system has its own position of equilibrium under any given set of conditions. For any given reversible reaction at equilibrium, the ratio of products to unreacted reactants remains constant. The numerical value of this ratio is called the equilibrium constant for the given reaction.

3.4.1 The equilibrium constant K_c

The equilibrium-constant expression for any reaction is obtained from the balanced chemical equation as follows:

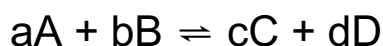

For the general equation above, the equilibrium constant expression would be:

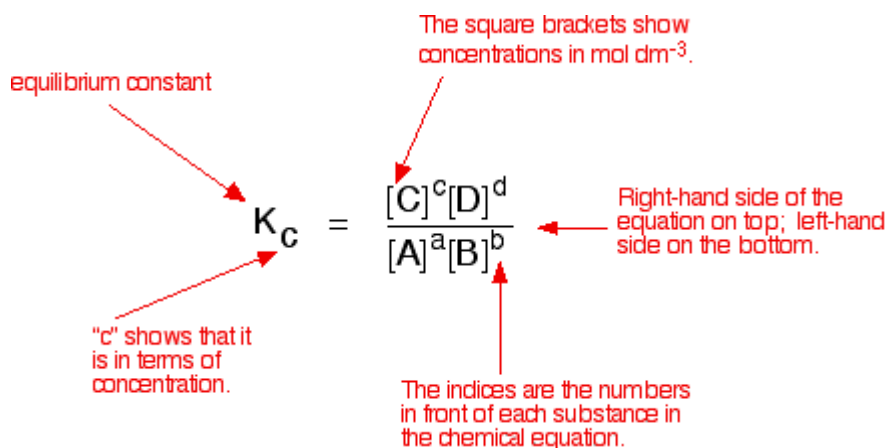

Also known as the Law of mass action – this expression has been determined experimentally and shown to fit all reversible reactions.

© 2013 Accenture. All rights reserved.

be > your degree

Bring your talent and passion to a global organization at the forefront of business, technology and innovation. Discover how great you can be.

Visit accenture.com/bookboon

Be greater than.
consulting | technology | outsourcing

>
accenture
High performance. Delivered.

3.4.2 Example

For the following reaction:

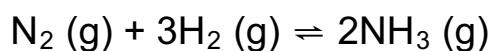

Equilibrium constant is equal to:

$$K_c = \frac{[\text{NH}_3]^2}{\{[\text{N}_2] \times [\text{H}_2]^3\}}$$

Note that the stoichiometric coefficients in the balanced equation always become the powers to which the concentrations are raised.

3.4.3 Equilibrium Law – Key Points

A large K_c indicates large concentrations of products at equilibrium as follows:

- $K_c > 1000$ means that the reaction goes to completion.

A small K_c indicates large concentrations of unreacted reactants at equilibrium:

- $K_c < 0.001$ means that the reaction does not happen.

The equilibrium law only applies to systems at equilibrium. The equilibrium constant, K_c , is the value obtained for the equilibrium-constant expression when equilibrium concentrations are substituted.

The numerical value of K_c is **unaffected by changes in the concentrations** of reactants or products. K_c is constant at constant temperature; however if the **temperature changes**, the value for the **equilibrium constant will change**.

3.4.4 Exercise

What would be the expression for the equilibrium constant for the following reactions?

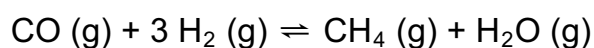
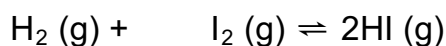

3.5 Equilibrium law for heterogeneous reactions

In heterogeneous systems where two or more phases are present at equilibrium (e.g. solid and gas), the **equilibrium is unaffected by the amounts of pure solids or pure liquids present**, as long as some of each is present. This is because the concentrations of solids and liquids are constant.

For example, $[\text{H}_2\text{O}(\text{l})] = \text{density/RMM} = 1000 \text{ g dm}^{-3} / 18 \text{ g mol}^{-1} = 55.56 \text{ mol.dm}^{-3}$. In a heterogeneous system $[\text{H}_2\text{O}]$ is always this value and has been included in the rate constant.

Consider the following equilibrium:

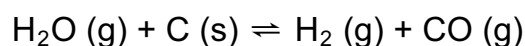

The equilibrium constant expression is adapted to include this constant term in the following K_c value:

$$K_c = [\text{H}_2] \times [\text{CO}] / [\text{H}_2\text{O}]$$

3.5.1 Exercise

What would be the expression for the equilibrium constant for the following reactions?

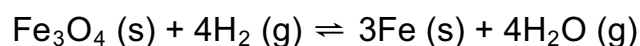
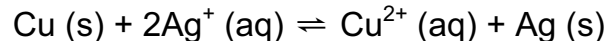

3.6 Obtaining equilibrium constant expressions

Equilibrium concentrations for a reaction cannot be predicted theoretically. They must be obtained experimentally and then substituted into the equilibrium-constant expression in order to calculate a value for K_c .

3.6.1 Example

Consider the reaction below:

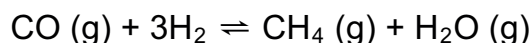

A series of experiments was done, starting with different concentrations and proportions of the reactants as shown in the table below.

	Starting concentrations		Equilibrium concentrations	Calculated value of K_c
Experiment 1	0.1000 M CO 0.3000 M H ₂	→	0.0613 M CO 0.1839 M H ₂ 0.0387 M CH ₄ 0.0387 M H ₂ O	$K_c = 3.93$
Experiment 2	0.2000 M CO 0.3000 M H ₂	→	0.1522 M CO 0.1566 M H ₂ 0.0478 M CH ₄ 0.0478 M H ₂ O	$K_c = 3.91$
Experiment 3	0.1000 M CH ₄ 0.1000 M H ₂ O	→	0.0613 M CO 0.1839 M H ₂ 0.0387 M CH ₄ 0.0387 M H ₂ O	$K_c = 3.93$

Experiments 1 and 2 start with the reactants; whereas experiment 3 starts with the products. The equilibrium-constant expression for this reaction is:

$$K_c = \frac{[\text{CH}_4] \times [\text{H}_2\text{O}]}{[\text{CO}] \times [\text{H}_2]^3}$$

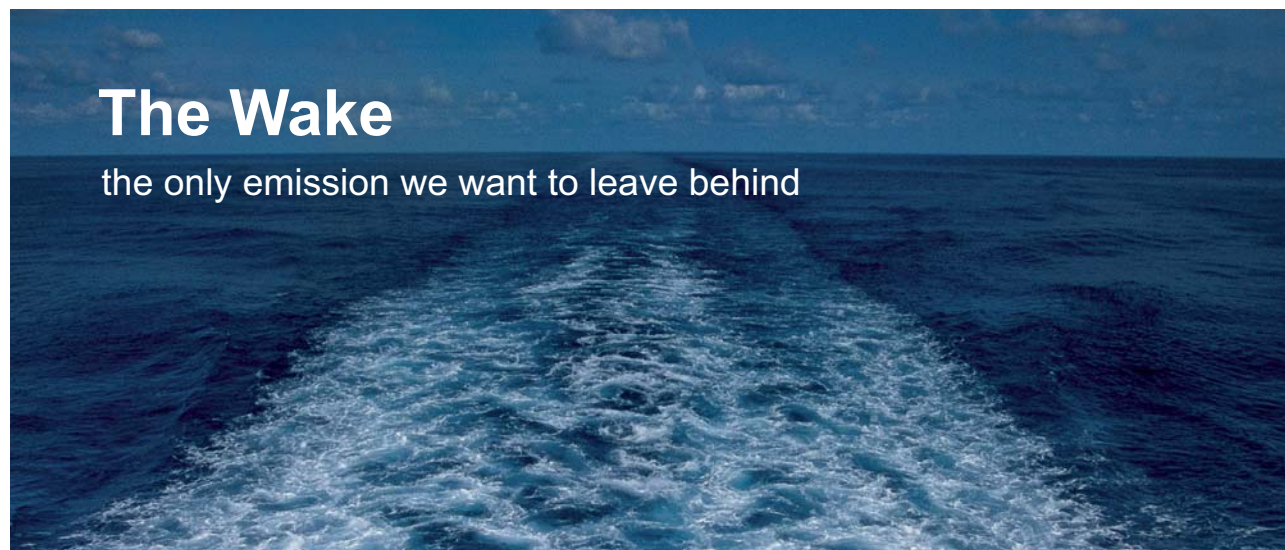

The Wake
the only emission we want to leave behind

Low-speed Engines Medium-speed Engines Turbochargers Propellers Propulsion Packages PrimeServ

The design of eco-friendly marine power and propulsion solutions is crucial for MAN Diesel & Turbo. Power competencies are offered with the world's largest engine programme – having outputs spanning from 450 to 87,220 kW per engine. Get up front!
Find out more at www.mandieselturbo.com

Engineering the Future – since 1758.
MAN Diesel & Turbo



If we substitute the equilibrium concentrations for any of the experiments as per the figures from the table above, we obtain the same ratio. For example, from experiment 1 we can calculate the following K_c :

$$K_c = (0.0387 \times 0.0387) / (0.0613 \times 0.1839^3)$$

$$K_c = 3.93$$

Regardless of the initial concentrations (whether they be reactants or products), the law of mass action means that the reaction will always settle into an equilibrium where the equilibrium-constant expression equals K_c .

3.6.2 Exercise

Calculate the equilibrium constant for the reaction shown below using the data in the table.

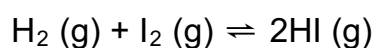

Experiment	Initial [H ₂]	Initial [I ₂]	Initial [HI]	Eq. [H ₂]	Eq. [I ₂]	Eq. [HI]	Value for K _c
1	0.00240	0.0138	0	0.00114	0.0120	0.0252	
2	0.00246	0.0176	0	0.00920	0.00220	0.0308	
3	0	0	0.0304	0.00345	0.00345	0.0235	
4	0	0	0.0758	0.00860	0.00860	0.0586	

3.7 Units of equilibrium constants

Note that the units for K_c vary depending on the equilibrium expression.

- $K_c = \{[\text{CO}] \times [\text{H}_2]\} / [\text{H}_2\text{O}]$ in mol.dm^{-3}
- $K_c = \{[\text{CO}_2] \times [\text{H}_2]\} / \{[\text{CO}] \times [\text{H}_2\text{O}]\}$ without any units

3.7.1 Exercise

What are the units for the following equilibrium constant?

$$K_c = \{[\text{CH}_4] \times [\text{H}_2\text{O}]\} / \{[\text{CO}] \times [\text{H}_2]^3\}$$

3.8 Calculating equilibrium concentrations

If the equilibrium constant for a reaction is given, it is possible to calculate the concentrations of substances in the equilibrium mixture.

3.8.1 Example

Consider the following equilibrium:

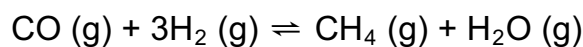

A gaseous mixture at equilibrium contains 0.30 mol of CO, 0.10 mol of H₂, 0.020 mol of H₂O and an unknown amount of CH₄ in a 1.0 dm³ container. What is the concentration of CH₄ in this mixture if the equilibrium constant K_c equals 3.92 mol⁻².dm⁶?

First, calculate concentrations from moles of substances.

- [CO] = 0.30 mol / 1.0 dm³ = 0.30 mol.dm⁻³
- [H₂] = 0.10 mol / 1.0 dm³ = 0.10 mol.dm⁻³
- [H₂O] = 0.02 mol / 1.0 dm³ = 0.02 mol.dm⁻³

The equilibrium constant K_c for this equation is given as:

$$K_c = \{[\text{CH}_4] \times [\text{H}_2\text{O}]\} / \{[\text{CO}] \times [\text{H}_2]^3\}$$

Substituting the known concentrations and the value of K_c gives:

$$3.92 = ([\text{CH}_4] \times 0.02) / (0.3 \times 0.02^3)$$
$$[\text{CH}_4] = 0.059 \text{ mol.dm}^{-3}$$

The concentration of CH₄ in the mixture is equal to 0.059 mol.dm⁻³.

Suppose we begin a reaction with known amounts of starting materials and want to calculate the quantities at equilibrium.

Use the stoichiometry of the equation to work out how the number of moles of reactants will change. Then convert the moles to concentration before putting into the K_c expression.

3.9 General steps to follow

- Set up a table of moles (starting, change, and equilibrium expressions in x) and include a row for calculating the concentrations.
- Convert the equilibrium expressions in x to concentrations.
- Substitute the expressions in x for the equilibrium concentrations into the equilibrium-constant equation.
- Solve the equilibrium-constant equation for x .
- Calculate the equilibrium concentrations.

3.9.1 Exercise

Suppose 1.0 mol of H_2 and 2.0 mol of I_2 are placed in a 5.0 dm^3 vessel.

What is the concentration of each substance are in the gaseous mixture when it comes to equilibrium at 458°C ? K_c at this temperature is 49.7.

3.9.2 Exercise

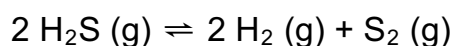

If 0.10 mol H_2S was put into a 10 dm^3 container and heated to 1132°C it makes an equilibrium mixture containing 0.0285 mol H_2 . What is the value of K_c at this temperature?

SMS from your computer

...Sync'd with your Android phone & number

Go to

BrowserTexting.com

and start texting from your computer!

BrowserTexting

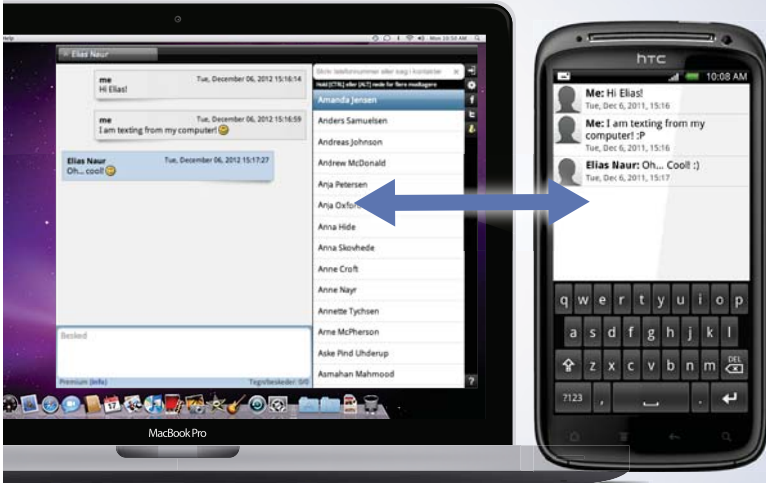

3.10 Equilibrium constant for the sum of reactions

We can combine equilibrium reactions whose K_c values are known to obtain K_c for the overall reaction

3.10.1 Combining rules

1. If a reaction is reversed, invert the value of K_c .
2. If each of the coefficients in an equation are multiplied by the same factor (2, 3, etc), raise K_c to the same power (2, 3, etc).
3. If each coefficient in an equation is divided by the same factor (2, 3, etc), take the corresponding root of K_c (i.e., square root, cube root, etc).
4. When the individual equations are combined / added together, take the product of the equilibrium constants to obtain the overall K_c .

3.10.2 Equilibrium constant for the sum of reactions

For example, nitrogen and oxygen can combine to form either NO (g) or N_2O (g) according to the following equilibria.

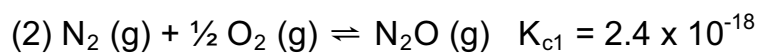
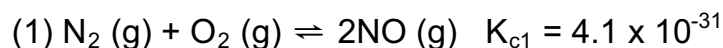

Using these two equations, we can obtain K_c for the formation of NO (g) from N_2O (g):

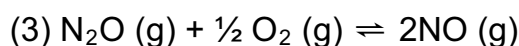

To combine equations (1) and (2) to obtain equation (3), equation (2) must be first reversed. Then the reciprocal of its K_c value must be taken as shown in the example below:

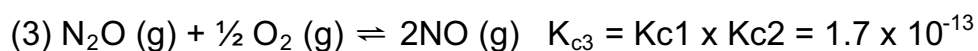
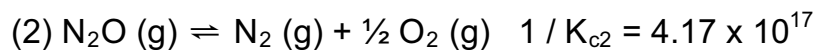
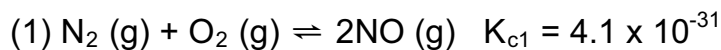

3.10.3 Exercise

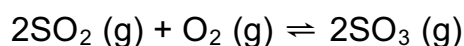

A 2.0 dm³ container was filled with 0.0400 mol of SO₂ and 0.0200 mol of O₂. At equilibrium, the flask contained 0.0296 mol of SO₃.

- How many moles of each substance were in the container at equilibrium?
- Calculate K_c

Summary

In chemical equilibria, the equilibrium concentrations of reactants and products are defined by an equilibrium constant called K_c given by

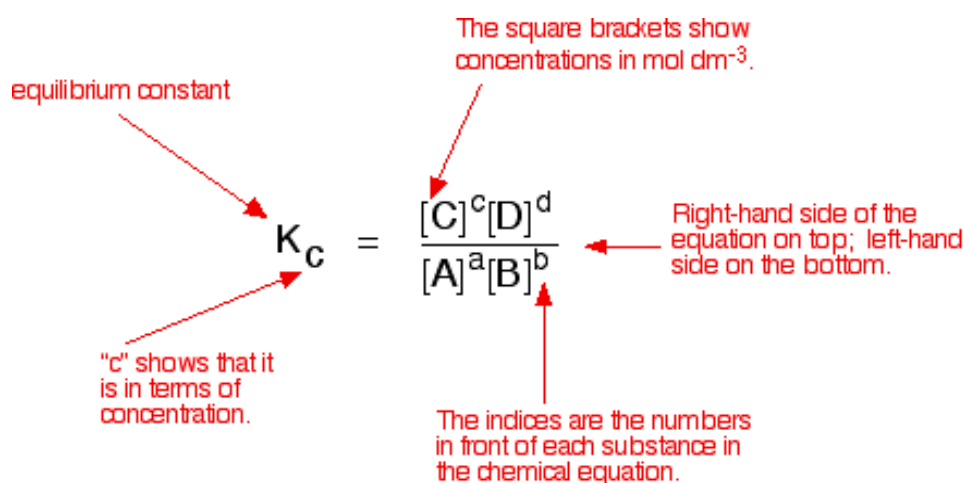

For the following chemical reaction: $a\text{A} + b\text{B} \rightleftharpoons c\text{C} + d\text{D}$

4 Chemical Equilibrium (2)

Learning points

- Relate constants K_p and K_c
- Use the reaction quotient to predict the direction of a reaction
- Apply Le Chatelier's principle

Introduction

In discussing gas-phase equilibria, it is often more convenient to express concentrations in terms of partial pressures rather than molarities.

The **partial pressure** is the pressure which the gas would have if it filled the same volume by itself. The **total pressure** of a gas mixture is the sum of the partial pressures of each individual gas in the mixture.

It can be seen from the ideal gas equation that the partial pressure of a gas is proportional to its concentration (also referred to as **molarity** M).

YOUR WORK AT TOMTOM WILL
BE TOUCHED BY MILLIONS.
AROUND THE WORLD. EVERYDAY.

Join us now on www.TomTom.jobs

follow us on **LinkedIn**



#ACHIEVEMORE

TOMTOM 



$$P = (n/V) RT = M R T$$

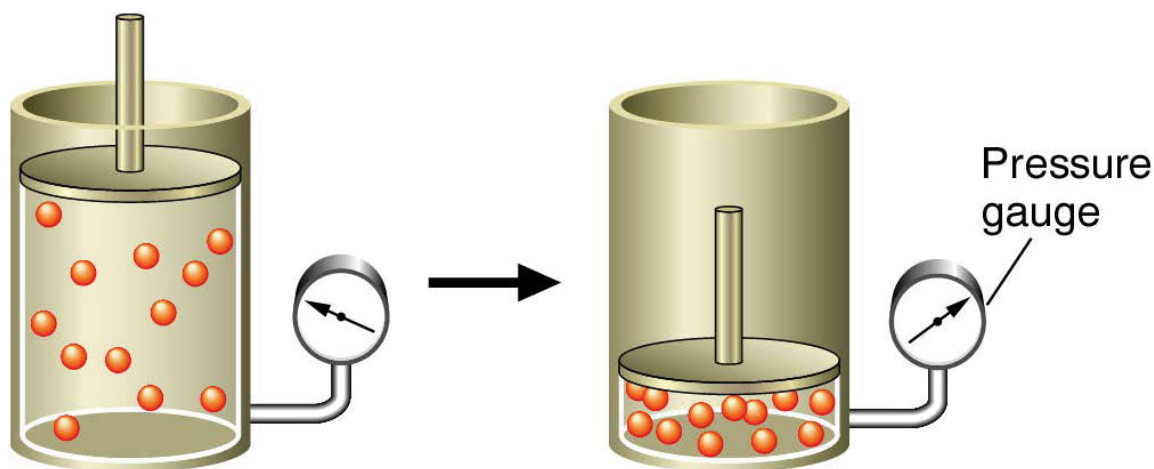

4.1 The Equilibrium Constant, K_p

If we express a gas-phase equilibria in terms of **partial pressures**, we obtain the equilibrium constant K_p . For the reaction below:

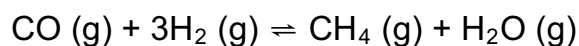

The equilibrium-constant expression in terms of partial pressures becomes:

$$K_p = \frac{P_{\text{CH}_4} P_{\text{H}_2\text{O}}}{P_{\text{CO}} P_{\text{H}_2}^3}$$

In general, the numerical value of K_p is not the same as the value of K_c . From the relationship $P V = n R T$, we show that

$$K_p = K_c (RT)^{\Delta n}$$

Where:

Δn is the total amount of moles of gaseous product LESS the total amount of moles of gaseous reactant.

Consider the following reaction:

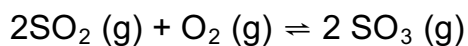

Reaction constant K_c for the reaction is 2.8×10^2 at $1,000^\circ\text{C}$. Calculate K_p for the reaction at this temperature.

We know that:

$$K_p = K_c (RT)^{\Delta n}$$

From the equation we see that $\Delta n = 2 - (2 + 1) = -1$. We can simply substitute the given reaction temperature and the value of R ($0.08206 \text{ dm}^3\cdot\text{atm}/\text{mol}\cdot\text{K}$) to obtain K_p .

Thus,

$$K_p = 2.8 \times 10^2 \times (0.08206 \times 1,000)^{-1}$$

$$K_p = 3.4$$

4.1.1 Predicting the Direction of a Reaction

How could we predict the direction in which a reaction at non-equilibrium conditions will shift to re-establish equilibrium?

Brain power

By 2020, wind could provide one-tenth of our planet's electricity needs. Already today, SKF's innovative know-how is crucial to running a large proportion of the world's wind turbines.

Up to 25 % of the generating costs relate to maintenance. These can be reduced dramatically thanks to our systems for on-line condition monitoring and automatic lubrication. We help make it more economical to create cleaner, cheaper energy out of thin air.

By sharing our experience, expertise, and creativity, industries can boost performance beyond expectations. Therefore we need the best employees who can meet this challenge!

The Power of Knowledge Engineering

Plug into The Power of Knowledge Engineering.
Visit us at www.skf.com/knowledge

SKF

The reaction quotient, Q_c , is an expression that has the same form as the equilibrium-constant expression but whose concentrations are not necessarily at equilibrium. Substitute the current concentrations into the Q_c expression and compare it to K_c .

4.1.2 Reaction Quotient Q_c

For the general reaction:

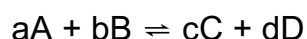

The Q_c expression would be:

$$Q_c = \frac{[C]_i^c [D]_i^d}{[A]_i^a [B]_i^b}$$

Where $[C]_i$ is the concentration of C at a particular instant in time (not necessarily at equilibrium)

4.1.3 Predicting the Direction of Reactions

If $Q_c > K_c$, the reaction will shift left; toward reactants.

If $Q_c < K_c$, the reaction will shift right; toward products.

If $Q_c = K_c$, then the reaction is at equilibrium as follows:

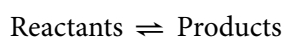

Consider the following equilibrium:

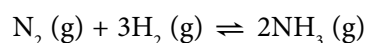

A 50.0 dm³ vessel contains 1.00 mol of N₂, 3.00 mol of H₂, and 0.500 mol of NH₃. In which direction (toward reactants or toward products) will the system shift to establish equilibrium at 400° C? K_c for the reaction at 400°C is equal to 0.500.

First, calculate concentrations from moles of substances as follows:

$$\begin{aligned} [N_2] &= 1.00 / 50.0 = 0.020 \text{ M,} \\ [H_2] &= 3.00 / 50.0 = 0.060 \text{ M, and} \\ [NH_3] &= 0.500 / 50.0 = 0.010 \text{ M.} \end{aligned}$$

The Q_c expression for the system is given below:

$$Q_c = \frac{[NH_3]^2}{[N_2][H_2]^3}$$

Substituting these concentrations into the reaction quotient gives:

$$Q_c = 23.1$$

Because $Q_c = 23.1 > K_c = 0.500$, the reaction will go to the left (toward the reactants) as it approaches equilibrium.

An equilibrium position will always shift if the amount of any substance in the equilibrium mixture is changed. If more reactant is added, or if product is removed, then the equilibrium position will **shift to the right** i.e. react to produce more product and less reactant. This is one example of an important general rule known as **Le Chatelier's principle**.

4.2 Le Chatelier's principle

Le Chatelier's principle states that “**when a system in a chemical equilibrium is disturbed by a change of temperature, pressure, or concentration, the equilibrium will shift in a way that tends to counteract this change.**”

Consider the following chemical equilibrium:

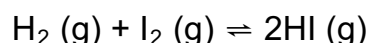

Predict the effect on the equilibrium position if

- Some H_2 was removed: Equilibrium will be **shifted towards the left**
- More H_2 was added: Equilibrium will be **shifted towards the right**
- $[HI]$ was reduced: Equilibrium will be **shifted towards the right**

4.2.1 Adding extra solid or liquid

Note that if the concentration of a substance cannot be changed (i.e. for a **pure liquid or solid** in a heterogeneous equilibrium), then a change in the amount present will have **no effect** on the equilibrium position.

4.2.2 Effects of Pressure Change

Le Chatelier's Principle can also be used to predict how **changing the pressure** can also **alter the position of equilibrium**. The pressure of a gas is related to the number of moles in a certain volume. So we can make the pressure change by reducing or increasing the volume of the reaction vessel.

If the total number of molecules of gaseous product is different to the total number of molecules of gaseous reactant, then the pressure will change by itself if the equilibrium position shifts.

If the products in a gaseous reaction contain fewer moles of gas than the reactants, the products would require less space. So, reducing the volume of the reaction vessel would, therefore, favour the products.

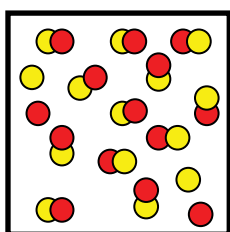

Mostly diatomic molecules:

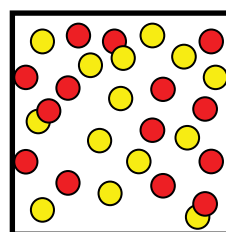

Mostly individual atoms: higher pressure

> Apply now

REDEFINE YOUR FUTURE
AXA GLOBAL GRADUATE PROGRAM 2015

redefining / standards 

agence.cdg. © Photonistop

Consider the following reaction:

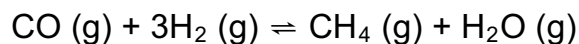

The figure below shows the above reaction at equilibrium and its compression

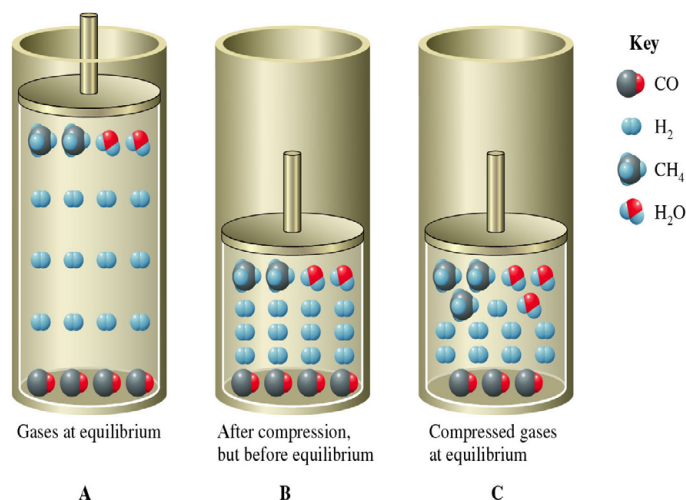

Conversely, if the reactants require less volume (i.e. fewer moles of gaseous reactant) then decreasing the volume of the reaction vessel would shift the equilibrium to the left (i.e. toward the reactants). Literally squeezing the reaction will cause a **shift** in the equilibrium toward the **fewer moles of gas**. **Reducing the pressure** in the reaction vessel **by increasing its volume** would have the **opposite effect**.

Le Chatelier's principle can be applied to pressure changes in the following way: "when a system in a chemical equilibrium is disturbed by a change of pressure, the equilibrium will shift in a way that tends to counteract this change." So, if **we increase** the pressure, the equilibrium will shift in whichever direction will **reduce the pressure** and vice versa.

A pressure change caused by changing the volume of the reaction vessel will affect the yield of products in a gaseous reaction only if there is **a change in the total moles of gas present**. If the number of moles of gaseous product equals the number of moles of gaseous reactant, changing the volume of the reaction vessel will have **no effect** on the position of the equilibrium.

4.2.3 Effect of Temperature Change

Temperature has a **significant effect** on most reactions. The position of the equilibrium will shift with a change of temperature. Reaction rates generally increase with an increase in temperature. Consequently, equilibrium is **established sooner**. Also, the value of the equilibrium constant **K_c varies with temperature**.

The effect on the position of equilibrium of increasing the temperature (in other words, adding heat) can be predicted using Le Chatelier's principle. Heat can be treated as if it were another substance being produced or used up in the reaction.

Heat can be treated as if it were a **product** in **exothermic reactions** as follows:

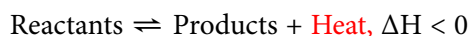

Increasing temperature is similar to adding more of the product. This will cause the equilibrium to shift in the direction **which counteracts** the imposed temperature increase by **using up heat**, i.e. to the left, and therefore increasing the amount of reactants.

Heat behaves as a reactant in **endothermic** reactions as follows:

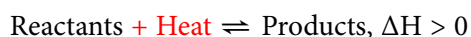

Increasing temperature is similar to adding more reactant. This will cause the equilibrium to shift to the **right**, counteracting the imposed temperature change by **using up heat**, and therefore increasing the amount of products.

4.2.4 Effect on K_c

Changing the amount of reactants and products will affect the concentrations in the K_c expression, and hence the K_c value. K_c will thus **decrease** at higher temperatures **for exothermic reactions**. Similarly, K_c increases at higher temperatures **for endothermic reactions**.

Consider the reaction below with associated enthalpy:

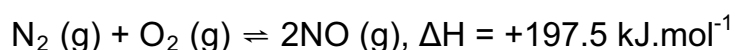

- i. What would be the effect on the position of the chemical equilibrium of the following
 - increasing the temperature? **Shift equilibrium to the right**
 - decreasing the temperature? **Shift equilibrium to the left**

- ii. How would each of these temperature changes affect the value of K_c ?
 - increasing the temperature? K_c will increase
 - decreasing the temperature? **K_c will decrease**

4.3 Manipulating yields

Adjusting the temperature, pressure and concentration of reactants can therefore have a large effect on the position of equilibrium. Le Chatelier's principle is applied to industrial processes to maximise the yield of the desired product.

4.3.1 Haber's Process

This reaction is very important in industry and produces ammonia as follows:



Increasing the pressure to 250 atm forces the equilibrium to shift to the right (the side with the smaller number of moles in the reaction equation), with effect to produce more of the desired product, ammonia.

However, it is a more complex decision to select the best temperature for this reaction. Le Chatelier's Principle predicts that more ammonia will be produced at low temperatures, as the reaction is exothermic. Although this is true, the reaction is so slow when cold, that it takes significant amount of time to reach the equilibrium.

4.3.2 Use of catalysts

Hence, the reaction is usually done at a medium temperature (450°C) with the additional help from an iron catalyst to help speeding up the reaction. By definition, a catalyst is a substance that increases the rate of a reaction but is not consumed by it. Moreover, a catalyst does not affect the position of equilibrium.

Summary

For gaseous reactions, another constant (K_p) can be defined in terms of the partial pressures of reactants and products (in atmospheres). For the following reaction:

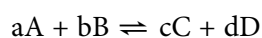

The reaction constants K_p and K_c can be defined as follows:

$$K_p = K_c (RT)^{\Delta n}$$

The reaction quotient Q_c can be used to predict which way a reaction mixture will move towards equilibrium. Q_c is defined as follows:

$$Q_c = \frac{[C]_i^c [D]_i^d}{[A]_i^a [B]_i^b}$$

In response to changes in conditions (addition/removal of reacting species, altered pressure or temperature) the equilibrium composition will move in a direction to reduce the effect of the change. This is known as Le Chatelier's principle. Using catalysts will not affect the equilibrium composition, but will speed up its completion.



LIGS University
based in Hawaii, USA

is currently enrolling in the
Interactive Online **BBA, MBA, MSc,**
DBA and PhD programs:

- ▶ enroll **by October 31st, 2014** and
- ▶ **save up to 11%** on the tuition!
- ▶ pay in 10 installments / 2 years
- ▶ Interactive **Online** education
- ▶ visit www.ligsuniversity.com to find out more!

Note: LIGS University is not accredited by any nationally recognized accrediting agency listed by the US Secretary of Education. More info [here](#).



5 Acids and Bases

Learning Points

- Predict simple reactions of acids and bases
- Identify acid and base using:
 - The Arrhenius theory,
 - The Brønsted-Lowry theory, and
 - The Lewis theory
- Calculate the concentration of H⁺ and OH⁻ ions in solutions of strong acids and bases
- Calculate the pH from the H⁺ ion concentration and vice versa

Acids are a family of chemicals which react in a similar way. For example, acids found in foodstuff give a characteristic sharp taste.

Metal hydroxides, oxides or carbonates are part of another family called base. A soluble base is called an alkali.

5.1 Reactions of acids

Acids often react to produce ionic compounds referred to as salts. Note that salt is a chemical term that covers any ionic metal compounds, e.g. potassium hydroxide, calcium carbonate, etc.

The salt formed will depend on the metal cation of the base and the non-metal or polyatomic anion of the acid.

5.1.1 Typical reactions of acids

i. Acid + Metal → Salt + Hydrogen

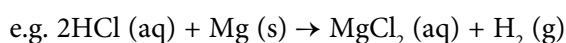

ii. Acid + Base → Salt + Water

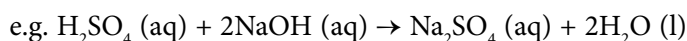

iii. Acid + Carbonate → Salt + CO₂ + Water

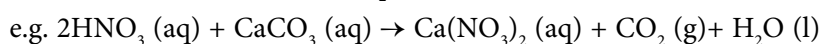

5.2 Acid-Base theories

There are three main theories that define Acids and Bases:

- The **Arrhenius theory**,
- The **Brønsted-Lowry theory**, and
- The **Lewis theory**

5.2.1 Arrhenius theory

According to the Arrhenius theory an **acid** is a substance that, when dissolved **in water**, produces **hydronium ions** (H_3O^+) as follows:

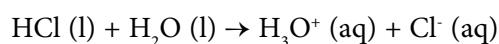

Chemists often simply call this the hydrogen ion, and use the notation H^+ (aq) as shorthand for the H_3O^+ (aq) ion.

Be aware, however, that the hydrogen ion H^+ in solution is actually chemically bonded to water, i.e. H_3O^+ .

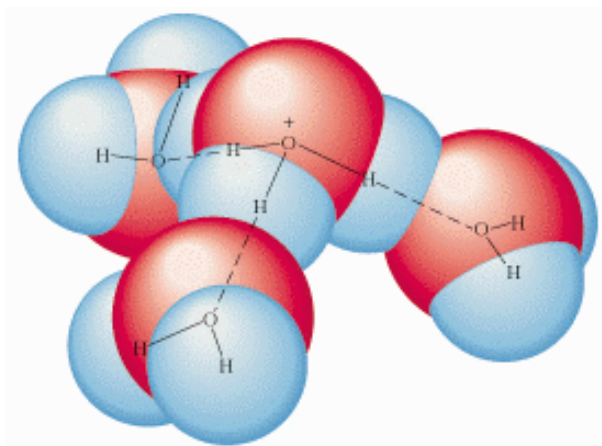

Hydrogen bonding makes the hydrated ion even larger: the H_3O^+ shown above forms hydrogen bonding with three more water molecules and therefore is usually just written **H^+ (aq)**.

Similarly, the Arrhenius theory states that when **bases** dissolve **in water**, they form **hydroxide ions**, OH^- as shown below:

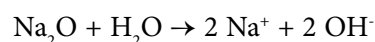

The Arrhenius theory is limited in that it looks at **acids and bases in aqueous solutions only**. In addition, it singles out the OH^- ion as the source of the base character, when other species can play a similar role. Broader definitions of acids and bases were then developed.

5.2.2 Brønsted-Lowry theory

The Brønsted-Lowry theory discusses acid-base reactions in terms of proton-transfer only. Note that an H atom only has one proton and one electron, as such a proton is exactly the same as an H^+ ion. The Brønsted-Lowry theory states that **an acid** is defined as **a proton donor** and **a base** is defined as a **proton acceptor**.

5.2.2.1 Conjugate acid-base pairs

The Brønsted-Lowry theory identifies acids and bases as **conjugate pairs**, which transform into each other with the loss or gain of a proton. It views all acid-base reactions as equilibrium as follows:



The general form of an acid can be written **HA**. When an **acid donates a proton**, it becomes the **conjugate base A⁻**. In the reverse reaction, when a **base A⁻ accepts a proton**, it becomes its **conjugate acid HA**.

TURN TO THE EXPERTS FOR SUBSCRIPTION CONSULTANCY

Subscribe is one of the leading companies in Europe when it comes to innovation and business development within subscription businesses.

We innovate new subscription business models or improve existing ones. We do business reviews of existing subscription businesses and we develop acquisition and retention strategies.

Learn more at [linkedin.com/company/subscribe](https://www.linkedin.com/company/subscribe) or contact
Managing Director Morten Suhr Hansen at mha@subscribe.dk

SUBSCRIBE - to the future



2.2.2.2 Amphoteric nature of water

Water is **amphoteric** meaning that it can act as **both an acid and a base**. The amphoteric characteristic of water is important in the acid-base properties of aqueous solutions.

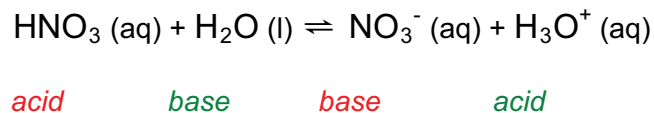

In the forward reaction, HNO_3 donates a proton to H_2O . Thus, HNO_3 is an acid and H_2O is here a base.

In the backward reaction, NO_3^- accepts a proton from H_3O^+ . Thus, NO_3^- is an acid and H_2O is a base.

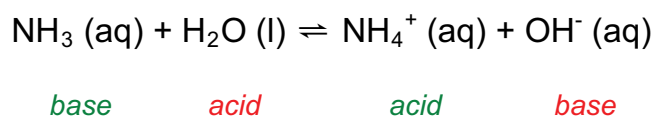

In this forward reaction, NH_3 accepts a proton from H_2O . Thus, NH_3 is a base and H_2O is an acid. In the backward reaction, NH_4^+ donates a proton to the OH^- . Here, the OH^- is a base and NH_4^+ is an acid.

5.2.2.3 Exercise

i) What is the conjugate acid of	ii) What is the conjugate base of
1. CH_3COO^-	1. HCl
2. HSO_4^-	2. H_3O^+
3. NH_3	3. NH_3
4. OH^-	4. HSO_4^-

5.2.2.4 Summary of Brønsted-Lowry theory

- An acid is a species which donates protons.
- A base is a species that accepts protons; OH^- is only one example of a base.
- Acids and bases can be molecular substances or ions.
- Acid-base reactions are not restricted to aqueous solution.
- Some species can act as either acids or bases depending on what the other reactant is. This is known as being amphoteric.

5.2.3 Lewis Theory of Acids and Bases

The Lewis theory defines an **acid** as an **electron pair acceptor** and a **base** as an **electron pair donor**. This theory broadened the scope of acid-base theory to include reactions that did not involve H^+ . The Lewis Theory embraces many reactions that we might not think of as acid-base reactions. The reaction of boron trifluoride with ammonia is an example.

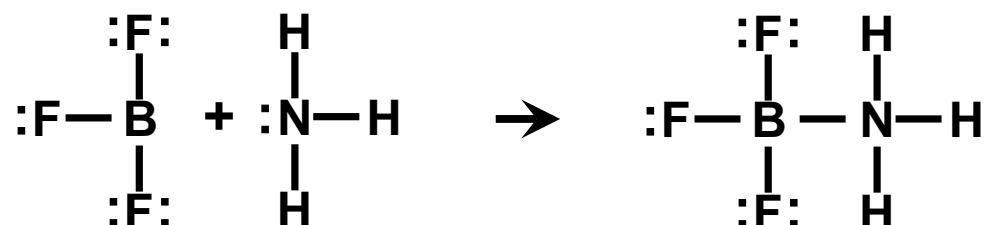

Boron trifluoride accepts the electron pair from the nitrogen atom of ammonia, so it is considered a Lewis acid. Ammonia donates the electron pair, so it is the Lewis base.

5.2.4 Strong acids

A **strong acid** is a substance that **ionises completely** in aqueous solution i.e. it exists in solution entirely as H_3O^+ and the conjugate base anion e.g. $HBr(l) + H_2O(l) \rightarrow Br^-(aq) + H_3O^+(aq)$

Other strong acids include:

- HCl: hydrochloric acid,
- HNO_3 : nitric acid,
- H_2SO_4 : sulphuric acid.

Similarly, a **strong base ionises completely** in aqueous solutions.

5.2.5 Weak acids

Most other acids and bases are **weak**. They are **not completely ionised** and exist in an equilibrium reaction with the hydronium ion and the conjugate base e.g. ethanoic acid is in equilibrium with the hydronium and ethanoate ions as follows:

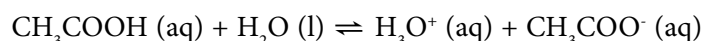

The equilibrium lies well to the left; where only about 2% of ethanoic acid is dissociated.

5.2.6 Relative Strength of Acids and Bases

The Brønsted-Lowry theory considers the proton-transfer reactions between conjugate acid-base pairs. Such acid-base reactions can be seen as a **competition** between species **for hydrogen ions**. From this point of view, we can **order acids** by their relative strength as **hydrogen ion donors**.

The **stronger acids** are those that lose their hydrogen ions more easily than other acids. Similarly, the **stronger bases** are those that hold onto hydrogen ions more strongly than other bases. If an acid loses its H^+ , the resulting anion is in a position to reaccept a proton, making it a Brønsted-Lowry base. It is logical to assume that if an acid is considered strong, its conjugate base (i.e. its anion) would be weak, since it is unlikely to accept a hydrogen ion.

5.2.6.1 Which acid is stronger?

The position of an acid-base equilibrium will depend on the relative strengths of the species involved.

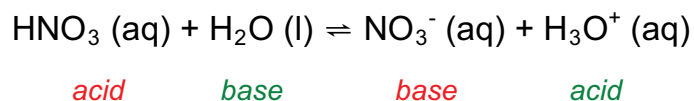

In the above system, we have two opposing Brønsted-Lowry acid-base reactions. HNO_3 is a much stronger acid than H_3O^+ , so the equilibrium lies far to the right.



"I studied English for 16 years but...
...I finally learned to speak it in just six lessons"
Jane, Chinese architect

ENGLISH OUT THERE

Click to hear me talking before and after my unique course download

5.2.6.2 Molecular Structure and Acid Strength

Two factors are important in determining the relative acid strengths. One factor is the **polarity of the bond** to which the hydrogen atom is attached. The H atom will have a partial positive charge.

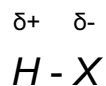

The more polarised the bond, the more easily the proton is removed and the greater the acid strength.

The second factor is the **strength of the bond** i.e. how tightly the proton is held. This depends on the size of atom X. The larger the atom X, the weaker the bond and the greater the acid strength.

Going **down a group** in the Periodic Table, the **atomic radius increases** markedly and the H-X bond strength decreases. One can predict the following order of acidic strength of acids made up of elements from Group 17 as follows:

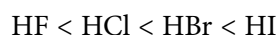

Going **across a period** in the Periodic Table of elements, the polarity of the H-X bond becomes the dominant factor. As **electronegativity increases** from the right to the left of the Periodic Table, the polarity of the H-X bond increases and the acid strength increases. One can predict the following order of acidic strength as follows:



Additionally, a **polyprotic acid** (e.g. H_2SO_4) is an acid which can donate **more than one proton**. Each successive H^+ ion becomes more difficult to be removed from the negative anion. Therefore, the acid strength of a polyprotic acid and its anions decreases with increasing negative charge as follows:



5.2.6.3 Acid strength

The strength of an acid is a measure of **how dissociated** it is in water; or how readily **it donates a proton** compared to water. Note that this is not the same as how concentrated it is.

Concentration is a measure of how many moles are dissolved per dm^3 . However, some of these molecules may not be dissociated into H^+ ions. So, for example it is possible to have a strong, dilute acid, or a weak concentrated acid.

5.2.7 Concentration of H⁺

For a strong acid, the concentration of the ions will equal the concentration of the acid. e.g. 0.1 M HCl (aq), [H⁺] = 0.1M

A more dilute solution will have a lower [H⁺]; e.g. 0.001 M HCl (aq), [H⁺] = 0.001M.

However for a 0.1 M solution of a weak acid such as ethanoic acid, we will find that [H⁺] << 0.1M. A more dilute solution of ethanoic acid will have an even lower [H⁺].

5.3 Self-ionisation of water

The amphoteric nature of water is seen even in pure water. Occasionally, one water molecule can donate a proton to another, forming ions.

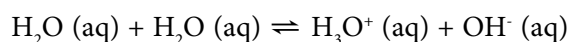

An equilibrium constant K_c expression can be written for this dissociation:

$$K_c = \frac{[\text{H}_3\text{O}^+][\text{OH}^-]}{[\text{H}_2\text{O}]^2}$$

The concentration of the ions is extremely small, so the concentration of H₂O remains essentially constant. Rearranging the above equation gives:

$$[\text{H}_2\text{O}]^2 K_c = [\text{H}_3\text{O}^+][\text{OH}^-]$$

5.3.1 Ionic product constant of water

[H₂O] and K_c are both constant and combining these constants together make up the ionic product constant for water, written K_w .

$$K_w = [\text{H}_3\text{O}^+][\text{OH}^-]$$

The value of K_w is $1.0 \times 10^{-14} \text{ mol}^2 \text{ dm}^{-6}$ at 25°C. Like any equilibrium constant, K_w varies with temperature.

These ions are produced in equal numbers in pure water, so

$$[\text{H}^+] = [\text{OH}^-] \times 10^{-14} = [\text{H}^+]^2$$

$$[\text{H}^+] = [\text{OH}^-] = 1.0 \times 10^{-7} \text{ mol.dm}^{-3}$$

Experiments have shown that the value for $[H^+] \times [OH^-]$ always equals 1.0×10^{-14} at 25°C even in solutions (such as acids or bases) where $[H^+] \neq [OH^-]$. This means that if $[H^+]$ is known, then $[OH^-]$ can be calculated, or vice versa.

5.3.2 Example

Calculate the concentration of OH^- ions in 0.10 M HCl.

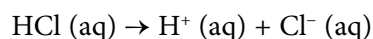

HCl is a strong acid, so $[H^+ \text{ (aq)}]$ will be 0.10 M.

Substituting $[H^+] = 0.10$ into the K_w expression, we get:

$$1.0 \times 10^{-14} = (0.10) \times [OH^-]$$

$$[OH^-] = 1.0 \times 10^{-13} \text{ M}$$

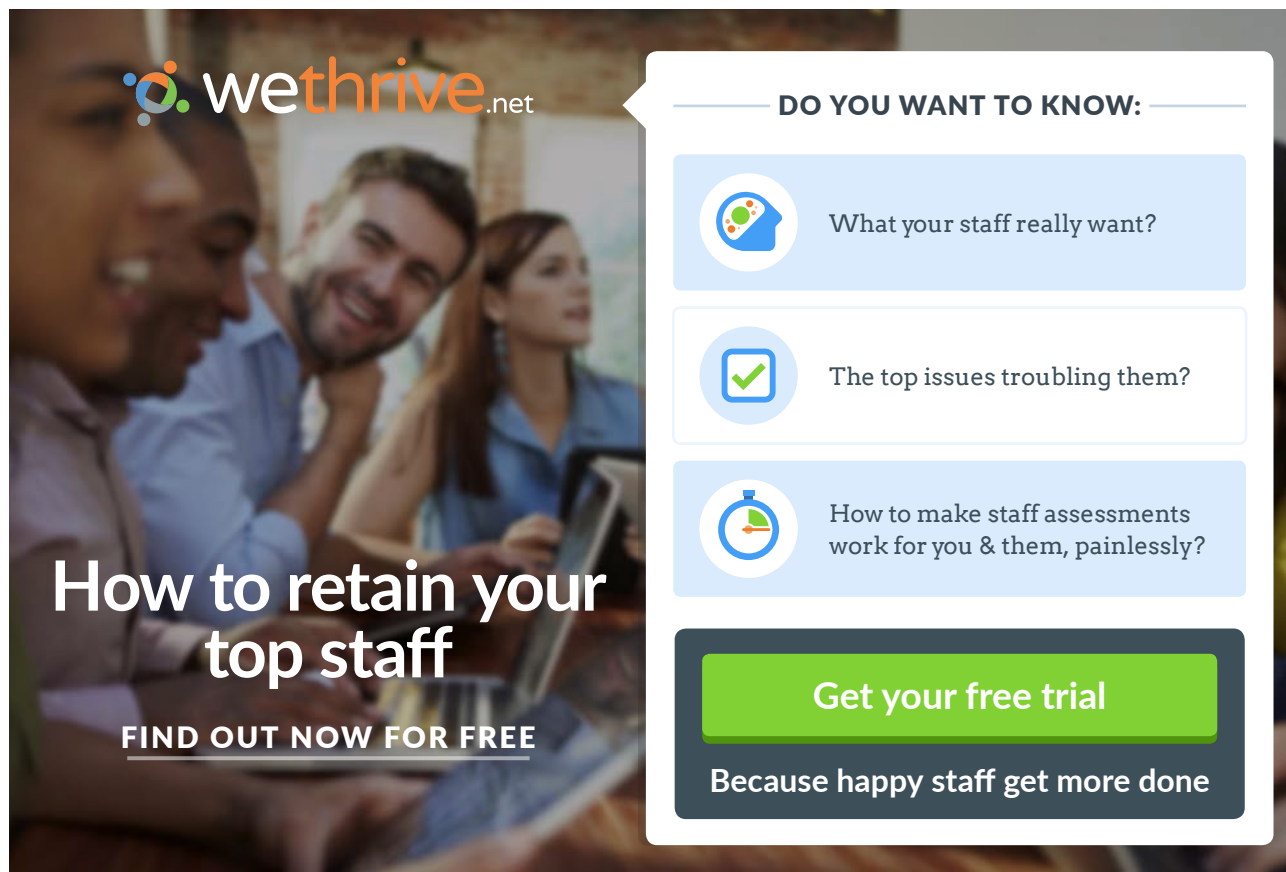

wethrive.net

How to retain your top staff
FIND OUT NOW FOR FREE

DO YOU WANT TO KNOW:

- What your staff really want?
- The top issues troubling them?
- How to make staff assessments work for you & them, painlessly?

Get your free trial
Because happy staff get more done

5.4 Solutions of Strong Acid or Base

Note that in a solution of a **strong acid** one can normally **ignore the self-ionisation of water** as a source of a few extra H^+ (aq). The concentration of H^+ ions is usually determined just from the strong acid concentration. However, the self-ionisation still exists so there is a small concentration of OH^- ions. Similarly, in a solution of a **strong base**, the self-ionisation still exists and is responsible for a small concentration of H^+ ions, while the concentration of OH^- ions is usually determined by the strong base concentration.

5.4.1 Example

Calculate the concentration of H^+ ions in 0.010 M NaOH.

NaOH is a strong base then $[\text{OH}^-] = 0.010 \text{ M}$. Substituting $[\text{OH}^-] = 0.010 \text{ M}$ into the ion-product expression, we get:

$$1.0 \times 10^{-14} = (0.010) \times [\text{H}^+]$$

$$[\text{H}^+] = 1.0 \times 10^{-12} \text{ M}$$

5.4.2 Exercise

Calculate the concentration of H^+ ions in:

- 0.75M solution of nitric acid (HNO_3)
- 2.0 M solution of potassium hydroxide (KOH)
- 0.05 M solution of sulphuric acid (H_2SO_4)
- 0.0020 M solution of calcium hydroxide

5.4.3 Acidic/Basic/Neutral

By dissolving other substances in water, one can alter the concentrations of H^+ (aq) and OH^- (aq).

In an acidic solution, the concentration of H^+ (aq) is greater than that of OH^- (aq). In a basic solution, the concentration of OH^- (aq) is greater than that of H^+ (aq). In a neutral solution, the concentrations of H^+ (aq) and OH^- (aq) are equal, as they are in pure water. Using the ion-product expression

$$K_w = [\text{H}^+] [\text{OH}^-]$$

At 25°C, $K_w = 1.0 \times 10^{-14}$ so

- In an **acidic solution**, $[H^+] > 1.0 \times 10^{-7} M$
- In a **neutral solution**, $[H^+] = 1.0 \times 10^{-7} M$
- In a **basic solution**, $[H^+] < 1.0 \times 10^{-7} M$

5.4.4 pH

Although one can quantitatively describe the acidity of a solution by its concentration $[H^+]$, it is more convenient to determine the acidity in terms of pH. The pH of a solution is defined as the negative logarithm of the molar hydrogen ion concentration as follows:

$$pH = -\log_{10} [H^+]$$

5.4.5 Example

For a solution in which the hydrogen-ion concentration is 1.0×10^{-3} , the pH is:

$$pH = -\log_{10} (1.0 \times 10^{-3}) = 3.00$$

Remember that the number of decimal places in the pH equals the number of significant figures in the hydrogen-ion concentration. Additionally, pH has no units.

5.4.6 pH of solutions

In a neutral solution, the hydrogen-ion concentration is $1.0 \times 10^{-7} M$, therefore pH is equal to 7.00. For acidic solutions, the hydrogen-ion concentration is greater than $1.0 \times 10^{-7} M$, so the pH is less than 7.00. Similarly, a basic solution has a pH greater than 7.00. Remember that a strong acid has a low pH.

5.4.7 The pH Scale

In the Figure below are shown the pH values of some common solutions.

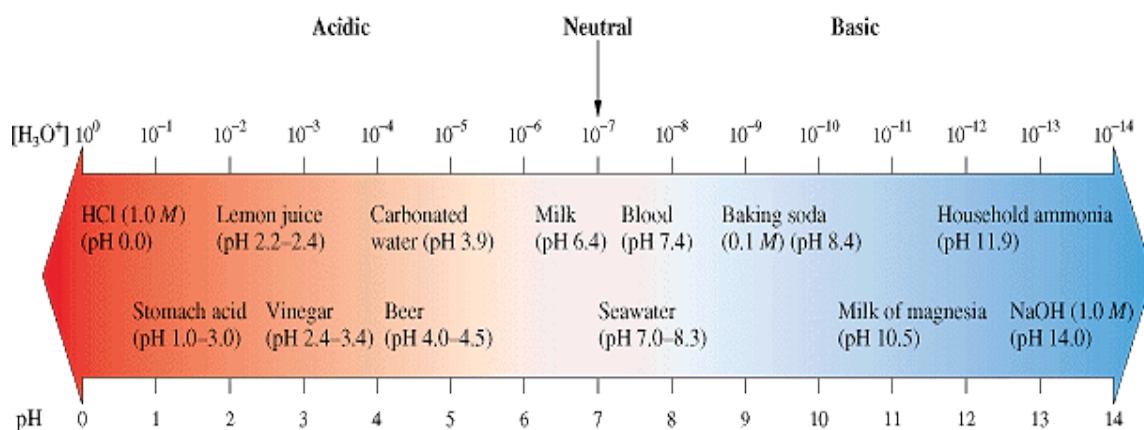

5.4.8 Exercise

A sample of orange juice has a hydrogen-ion concentration of 2.9×10^{-4} M. What is the pH?

5.4.9 Exercise

The pH of human arterial blood is 7.40. What is the hydrogen-ion concentration?

5.4.10 pOH

A measurement of the hydroxide ion concentration, similar to pH, is called pOH.

The pOH of a solution is defined as the negative logarithm of the molar hydroxide-ion concentration as follows:

$$\text{pOH} = -\log_{10} [\text{OH}^-]$$

Because $K_w = [\text{H}^+] \times [\text{OH}^-] = 1.0 \times 10^{-14}$ at 25°C, one can demonstrate that

$$\text{pH} + \text{pOH} = 14.00$$

gaiTeye
Challenge the way we run

EXPERIENCE THE POWER OF
FULL ENGAGEMENT...

.....

**RUN FASTER.
RUN LONGER..
RUN EASIER...**

READ MORE & PRE-ORDER TODAY
WWW.GAITEYE.COM

5.4.11 Example

A solution has a hydroxide-ion concentration of 1.9×10^{-3} M. What is the pH of the solution?

Firstly, calculate the pOH:

$$\text{pOH} = -\log_{10} (1.9 \times 10^{-3}) = 2.72$$

Then, calculate the pH:

$$\text{pH} = 14.00 - 2.72 = 11.28$$

5.4.12 Measuring pH

The pH of a solution can accurately be measured using a **pH meter**.

Although less precise, **acid-base indicators** are often used to measure pH because they usually change colour within a narrow pH range. Litmus is a common indicator which is red in acid and blue in alkali. There are many other acid-base indicators which change colour at various pH values as shown in the Figure below.

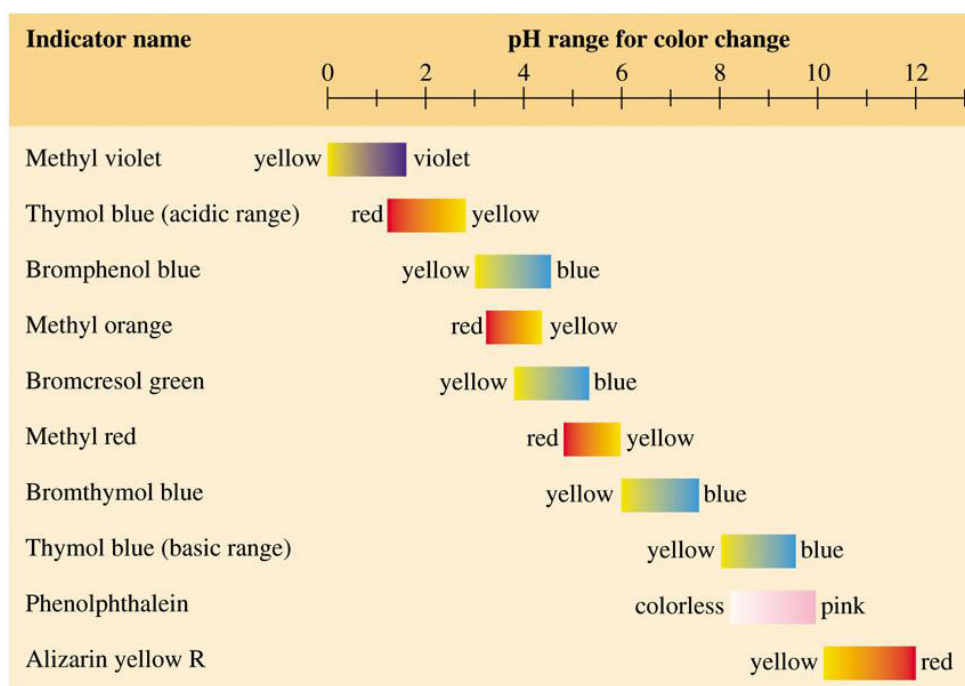

©Houghton Mifflin Company. All rights reserved.

Summary

According to the Arrhenius theory, an acid is a substance that, when dissolved in water, increases the concentration of hydronium ion (H_3O^+). A base, as per the Arrhenius Theory, is a substance that, when dissolved in water, increases the concentration of hydroxide ion, OH^- (aq). According to the Brønsted-Lowry definitions, an acid is a proton donor (a giver of H^+ ions) and a base is a proton acceptor (a taker of H^+ ions).

For every acid there is a conjugate base (formed by the loss of a proton) and for every base there is a conjugate acid (formed by the gain of a proton).

The Lewis Theory defines an acid as an electron pair acceptor and a base as an electron pair donor.

Water molecules can act either as an acid or a base, making water amphoteric. The self-ionisation of water can be represented by:

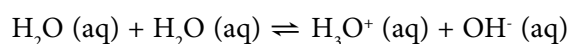

The dissociation constant for this ionisation is K_w , the ionic product of water: $K_w = [\text{H}_3\text{O}^+] \times [\text{OH}^-]$ or more simply, $K_w = [\text{H}^+] \times [\text{OH}^-]$.

K_w is temperature dependent and has a value of 1.0×10^{-14} at 25°C . The pH scale is based on the $[\text{H}^+]$ which is related to the pH by

$$\text{pH} = -\log [\text{H}^+]$$

This relationship can be used to calculate the concentration of H^+ ions and OH^- ions since changes in the concentration of one directly change the concentration of the other to maintain a constant K_w value.

6 Thermochemistry

Learning Points

- Write and manipulate thermo-chemical equations
- Apply Hess' law
- Calculate the enthalpy of a reaction from standard enthalpies of formation
- Understand and create Born Haber Cycles

6.1 Thermo-chemical Equations

A **thermo-chemical equation** is the chemical equation for a reaction in which the enthalpy of reaction for the molar amounts stated is written directly after the equation.

In a thermo-chemical equation it is important to note **state symbols** (solid, liquid or gas) because the enthalpy change, ΔH , depends on the phase of the substances.



This e-book
is made with
SetaPDF



SETASIGN

PDF components for **PHP** developers

www.setasign.com



6.1.1 Manipulating Thermo-chemical Equations

The following are two important rules for manipulating thermo-chemical equations:

- i. When a chemical equation is **reversed**, the value of ΔH is reversed in sign. For example,

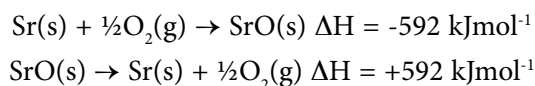

- ii. When a thermo-chemical equation is **multiplied** by any factor, the value of ΔH for the new equation is obtained by multiplying the ΔH in the original equation by that same factor. For example,

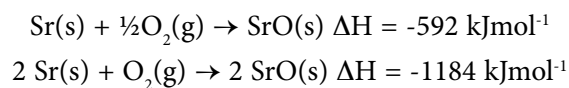

6.2 Hess's Law

How can the enthalpy ΔH be discovered if the enthalpy changes for reactions are too difficult or impossible to determine experimentally?

If for example, the reaction is too slow or too fast or by-products are formed it is possible to then use Hess's Law.

Definition: Hess's Law states that the overall reaction enthalpy is the sum of the reaction enthalpies of each step of the reaction. This is a direct application of the First Law of Thermodynamics, which states that energy cannot be created or destroyed.

Finally, if the enthalpy ΔH for each step of the reaction is known, then these steps can be combined to give ΔH for the overall reaction.

There are two general methods of carrying out calculations based on Hess's law: the pictorial method and the algebraic method.

The pictorial method requires a thermo-chemical cycle to show the energy changes between reactants and products in the different stages, whereas the algebraic method utilises only calculations.

In a chemical reaction, the energy change in converting reactants into products is the same, regardless of the route by which the chemical change occurs, as enthalpy is a state function. For example, the oxidation of carbon:

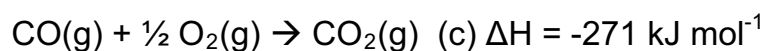
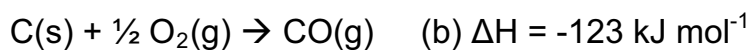

Equation (a) is the sum of equations (b) and (c) and therefore

$$\Delta H_{\text{a}} = \Delta H_{\text{b}} + \Delta H_{\text{c}}$$

6.3 Enthalpy diagram

The corresponding enthalpy diagram (also called “pictorial method”) for the three thermo-chemical equations discussed above is shown in the Figure below.

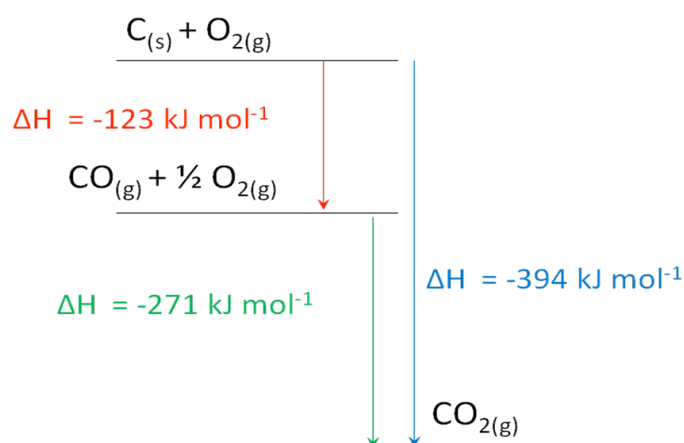

6.4 Calculating the Enthalpy change of a reaction

The simplest way to apply Hess’s Law is to remember that the enthalpy change of any reaction is equal to the total formation energy of the products minus that of the reactants as shown below:

$$\Delta H^{\circ} = \sum n\Delta H_f^{\circ}(\text{products}) - \sum m\Delta H_f^{\circ}(\text{reactants})$$

Where Σ is the mathematical symbol meaning “the sum of”, and m and n are the coefficients of the substances in the chemical equation.

6.4.1 Example

Ammonia is used in the industrial preparation of nitric acid according to the following equation:

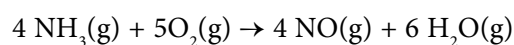

What is the standard enthalpy change ΔH for this reaction?

First, it is essential to record the values of ΔH_f° (readily found in data tables) under the formulae in the equation, multiplying them by the coefficients in the equation as follows:

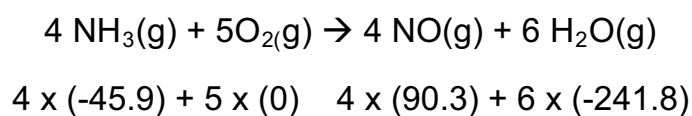

Then it is possible to calculate ΔH° by subtracting the values for the reactants from the values for the products or as follows

$$\Delta H^\circ = \sum n\Delta H_f^\circ(\text{products}) - \sum m\Delta H_f^\circ(\text{reactants})$$



Discover the truth at www.deloitte.ca/careers

Deloitte.

© Deloitte & Touche LLP and affiliated entities.



Then replace the values in the above equation:

$$\Delta H^\circ = [4 \times (90.3) + 6 \times (-241.8)] - [4 \times (-45.9) + 5 \times (0)] = -906 \text{ kJ}$$

Be careful with the arithmetic signs as they are a likely source of mistakes. Note that the units for this should just be **kJ** and not $\text{kJ}\cdot\text{mol}^{-1}$, as the value refers to the equation previously defined.

6.5 Enthalpy diagram

The corresponding enthalpy diagram for the industrial preparation of nitric acid NO from ammonia NH_3 is shown in the Figure below:

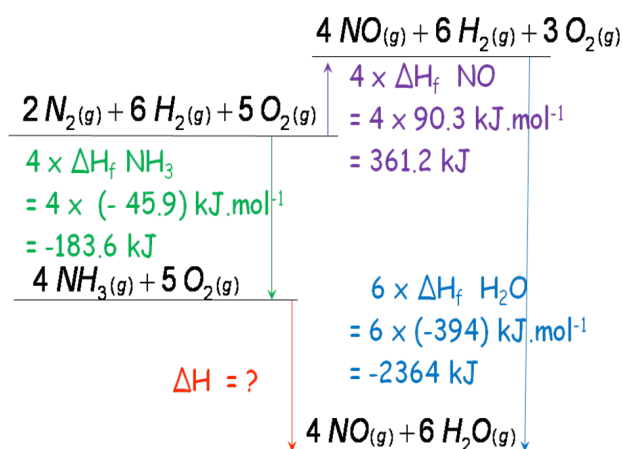

Note: when drawing enthalpy diagrams, remember that in **exothermic** reactions (the most common), **the products will finish at a lower energy level than the reactants**. Make sure that the arrows are drawn in the correct direction –upwards for positive enthalpy change, and downwards for negative enthalpy change.

6.6 Lattice Enthalpy

The strength of the covalent bonds can be measured by the bond enthalpy. In ionic compounds the comparable enthalpy value which relates to the strength of the ionic bonds is called the lattice enthalpy.

Lattice enthalpy is a measure of the attraction of all of the positive ions to all the surrounding negative ions in the crystal structure.

Definition: lattice enthalpy ΔH_L° is the enthalpy change when one mole of an ionic crystal is formed from the ions in a gaseous state under standard conditions.

Note: always look carefully at the equation or definition given in a question to see which is being used.

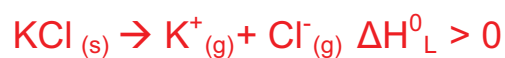

The above reactions can be drawn as shown in the Figure below:

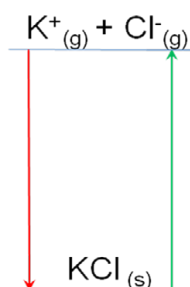

If you are unsure, remember that breaking bonds always requires energy, so the corresponding enthalpy will be endothermic.

be > your degree

Bring your talent and passion to a global organization at the forefront of business, technology and innovation. Discover how great you can be.

Visit accenture.com/bookboon

Be greater than.
consulting | technology | outsourcing

accenture
High performance. Delivered.

© 2013 Accenture. All rights reserved.

6.7 Born-Haber Cycles

Lattice enthalpies cannot be determined directly but an application of Hess's law to the formation of an ionic crystal called the 'Born-Haber cycle' can be used to calculate the value.

This cycle is an **imaginary closed path** that includes all the different enthalpy change steps involved in the enthalpy of formation. The steps can be drawn in any order, as long as the positive or negative signs are correct.

6.7.1 Born-Haber Cycle for sodium chloride NaCl

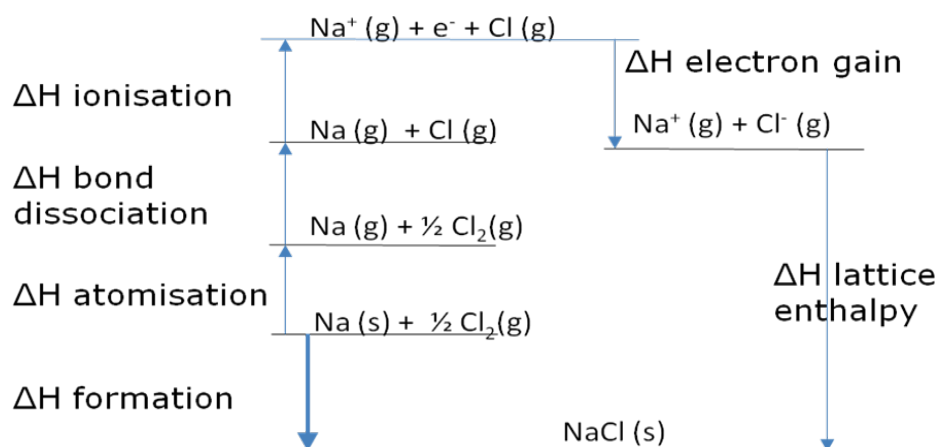

Hess's Law states that two alternative routes forming solid crystal Sodium Chloride from the elements Sodium Na and Chlorine Cl will have equal ΔH and as such:

$$\sum \Delta H \text{ by ROUTE 1} = \sum \Delta H \text{ by ROUTE 2}$$

The above means that if the enthalpy values are known for all the other steps, the lattice enthalpy can be calculated by **drawing** a Born-Haber cycle.

To successfully calculate enthalpy values one needs to be able to:

- Draw a Born Haber cycle for any simple (two element) ionic compound.
- Write the equations for each of the standard enthalpy change steps.
- Calculate any one of the enthalpy changes if given all of the others.

To carry out this task, follow the steps below:

- i. Keep the correct number of each atom to form one mole of the ionic compound.
- ii. Only make one change on each step.
- iii. Ensure that the element is in the correct state for the standard enthalpy change.
- iv. Pay extra attention with the positive and negative signs in the final calculation.
- v. Up arrows for endothermic ($\Delta H > 0$) and down arrows for exothermic ($\Delta H < 0$).

6.7.1.1 Standard enthalpy of formation (ΔH_f°)

Definition: One mole of the compound is formed from its elements in their standard states. For example, sodium chloride NaCl is formed from Na and Cl₂ as follows:

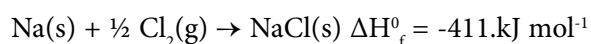

6.7.1.2 Standard enthalpy of atomisation ($\Delta H_{\text{atom}}^\circ$)

Definition: One mole of isolated atoms in the gas phase is made from an element in its standard state. For example, Na is a solid at room temperature and requires 109kJ to become a gas as shown below:



From our example, Cl₂ is already a gas; however chlorine is present as molecules, not as atoms as shown below:



6.7.1.3 Bond Dissociation Enthalpy

Sometimes the value for the bond dissociation enthalpy is instead given. Note that this bond dissociation enthalpy refers to one bond, so is double the value of the atomisation enthalpy as shown below:



6.7.1.4 First ionisation enthalpy ($\Delta H_{\text{ion}}^\circ$)

Definition: The first ionisation enthalpy ($\Delta H_{\text{ion}}^\circ$) is the energy required to remove one electron from each atom to form an ion. The standard refers to one mole of atoms in the gas phase.



6.7.1.5 Second ionisation enthalpy

If the metal M concerned forms M^{2+} ions, then the calculation of ionisation enthalpy needs to be done in two stages. The second ionisation enthalpy (ΔH_{ion}^0) is the energy required to remove a second electron from the M^+ ion to form an M^{2+} ion.

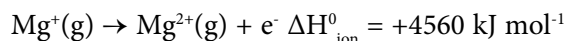

Note that for $\text{Mg}(\text{g}) \rightarrow \text{Mg}^{2+}(\text{g}) + 2e^-$, ΔH_{ion}^0 would be the sum of the first and second ionisation energies i.e. $502 + 4560 = +5062 \text{ kJ.mol}^{-1}$

6.7.1.6 Electron gain (ΔH_{eg}^0)

Definition: The electron gain (or electron affinity) (ΔH_{eg}^0) is the energy change when one electron is added to each atom to form a negative ion. Note that the standard refers to one mole of ions being formed in the gas phase.

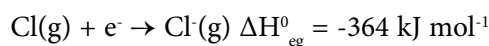
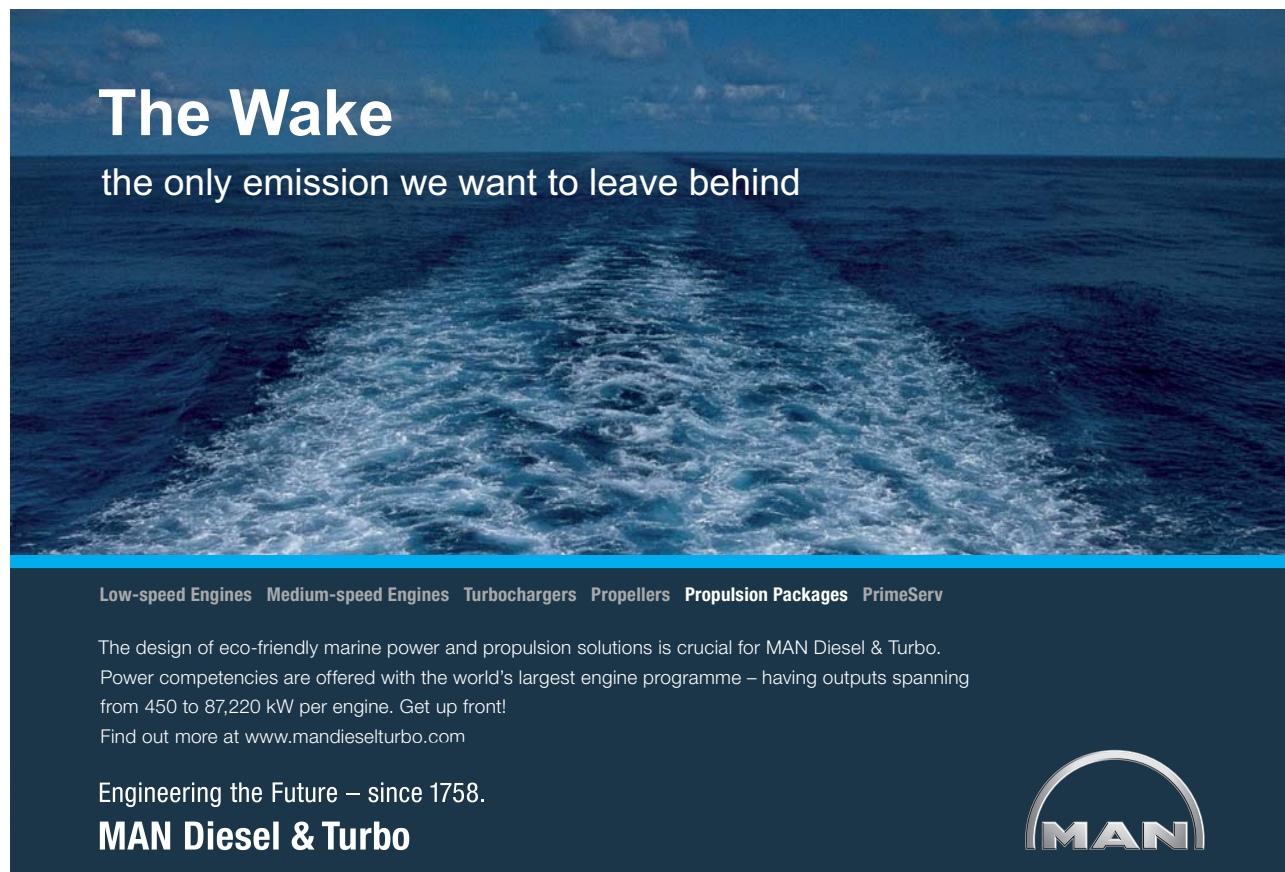



The Wake
the only emission we want to leave behind

Low-speed Engines Medium-speed Engines Turbochargers Propellers Propulsion Packages PrimeServ

The design of eco-friendly marine power and propulsion solutions is crucial for MAN Diesel & Turbo. Power competencies are offered with the world's largest engine programme – having outputs spanning from 450 to 87,220 kW per engine. Get up front!
Find out more at www.mandieselturbo.com

Engineering the Future – since 1758.
MAN Diesel & Turbo



If the non-metal NM concerned forms NM^{2-} ions, then the ionisation needs to be two stages. The second electron is the energy change needed when a second electron is added to the NM^- ion to form a NM^{2-} ion.

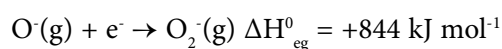

Note that although the first electron gain is always exothermic, the second is usually endothermic.

6.7.1.7 Lattice formation energy (ΔH_{L}^0)

Definition: The lattice formation energy (ΔH_{L}^0) is the enthalpy change when one mole of a solid ionic crystal is formed from the ions in a gaseous state under standard conditions as shown below for solid NaCl.

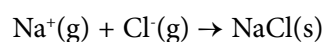

6.7.1.8 Calculating ΔH_{L}^0 for NaCl

Calculating the lattice formation energy ΔH_{L}^0 for NaCl from all of the above, using the Born-Haber cycle and the rule stating that $\Sigma\Delta H$ by ROUTE 1 = $\Sigma\Delta H$ by ROUTE 2, we can find that:

$$\begin{aligned} -411 &= +109 + 121 + 492 - 364 + \Delta H_{\text{L}}^0 \\ -411 - 109 - 121 - 492 - (-364) &= \Delta H_{\text{L}}^0 \text{ and } \Delta H_{\text{L}}^0 = -771 \text{ kJ mol}^{-1} \end{aligned}$$

Summary

Remember that an energy diagram can be used to show the energy pathway for a reaction. The definition of the enthalpy change is the energy difference between products and reactants. Typically, the enthalpy change has a negative value for exothermic reactions, which cause heat energy to be released to the surroundings, whereas the enthalpy change has a positive value for endothermic reactions, which causes absorption of heat energy from the surroundings.

The First Law of Thermodynamics states that energy can be changed from one form to another but it cannot be created or destroyed. This allows thermo-chemical cycles called ‘‘Hess’s Law cycles’’ to be used to calculate unknown enthalpy values. If a reaction can take place in more than one route, the overall enthalpy change is the same whichever route is taken.

Finally, Born-Haber cycles are enthalpy diagrams applied to the formation of ionic crystals only which can be used to determine enthalpies of lattice formation that cannot be determined by experiment. This is a direct application of the algebraic method.